

# Floor Machine

**MONSTER JANITORIAL** **CLICK TO ORDER PARTS**

Operating instructions (ENG)

MODELS:

**1.005.293.0**

**1.005-294.0**



Read these instructions before using the machine.

## **Machine Data Label**

---

Model:	_____
Date of Purchase:	_____
Serial Number:	_____
Dealer:	_____
Address:	_____
Phone Number:	_____
Sales Representative:	_____

### **Overview**

The Floor Machine is a mains powered, portable floor scrubber intended for commercial use. The appliance can be fitted with a variety of pads to perform various floor care functions.

## **Warranty Registration**

Thank you for choosing our product. Warranty registration is quick and easy. Your registration will allow us to serve you better over the lifetime of the product.

To register your product go to:

**<http://warranty.karcherna.com/warrantyregistration.aspx>**

**Machine Data Label** . . . . . 2  
 Overview . . . . . 2  
**Table of Contents** . . . . . 3  
**How To Use This Manual** . . . . . 4

**Safety**

IMPORTANT SAFETY INSTRUCTIONS . . . . . 5  
 HAZARD INTENSITY LEVEL . . . . . 7  
 SAFETY LABEL LOCATION . . . . . 10

**Operation**

Unpacking and Initial Operations . . . . . 13  
 Pre-Run Inspection . . . . . 14  
 Pump . . . . . 16  
 Process of Cleaning . . . . . 18  
 End of the Application . . . . . 18  
 Storage . . . . . 19  
 Lifting and Carrying . . . . . 20  
 Weight Kit Installation . . . . . 21  
 Brush Installation . . . . . 22  
 Changing the Water Bottle . . . . . 22  
 Attaching and Removing the Driver Plates . . . . . 23  
 Accessories And Applications . . . . . 24  
 Driver Plates . . . . . 24  
 Standard Driver Plate . . . . . 24  
 Pads . . . . . 25  
 Absorbent Pads . . . . . 25  
 Glider . . . . . 25  
 Carpet Pads . . . . . 26  
 Chemical Free Stripping Pad . . . . . 26  
 Multi-Purpose Brush . . . . . 27  
 Application on different Floor Types . . . . . 28  
 Carpet Cleaning . . . . . 28  
 Cleaning Hard Floors . . . . . 28

**Maintenance**

Cleaning the machine: . . . . . 29  
 Cleaning the spray system: . . . . . 29  
 Changing the Velcro driver discs . . . . . 29  
 Changing the filters . . . . . 30

**Parts**

Bottle Holder . . . . . 32  
 Deck . . . . . 34  
 Handle - Latch . . . . . 36  
 Handle - Lower . . . . . 38  
 Handle - Middle . . . . . 40  
 Handle - Upper . . . . . 42  
 Motor . . . . . 44  
 Nozzle . . . . . 46  
 Pad . . . . . 48  
 Solution . . . . . 50  
 Suggested Spare Parts . . . . . 52  
 Accessories . . . . . 53

## How To Use This Manual

This manual contains the following sections:

- How to Use This Manual
- Safety
- Operations
- Maintenance
- Parts List

The HOW TO USE THIS MANUAL section will tell you how to find important information for ordering correct repair parts.

Parts may be ordered from authorized dealers. When placing an order for parts, the machine model and machine serial number are important. Refer to the MACHINE DATA box which is filled out during the installation of your machine. The MACHINE DATA box is located on the inside of the front cover of this manual.

Model: _____
Date of Purchase: _____
Serial Number: _____
Dealer: _____
Address: _____
Phone Number: _____
Sales Representative: _____

The model and serial number of your machine is located on the left side of the handle, from the operators perspective

The SAFETY section contains important information regarding hazardous or unsafe practices of the machine. Levels of hazards are identified that could result in product damage, personal injury, or severe injury resulting in death.

The OPERATIONS section is to familiarize the operator with the operation and function of the machine.

The MAINTENANCE section contains preventive maintenance to keep the machine and its components in good working condition. They are listed in this general order:

- Storage
- Maintenance
- Troubleshooting

The PARTS LIST section contains assembled parts illustrations and corresponding parts list. The parts lists include a number of columns of information:

- **REF** – column refers to the reference number on the parts illustration.
- **PART NO.** – column lists the part number for the part.
- **PRV NO.** – reference number.
- **QTY** – column lists the quantity of the part used in that area of the machine.
- **DESCRIPTION** – column is a brief description of the part.
- **SERIAL NO. FROM** – If this column has an (\*) and a Reference number, see the SERIAL NUMBERS page in the back of your manual. If column has two asterisk (\*\*), call manufacturer for serial number. The serial number indicates the first machine the part number is applicable to. The main illustration shows the most current design of the machine. When a boxed illustration is shown, it displays the older design.
- **NOTES** – column for information not noted by the other columns.

*NOTE: If a service or option kit is installed on your machine, be sure to keep the KIT INSTRUCTIONS which came with the kit. It contains replacement parts numbers needed for ordering future parts.*

*NOTE: The manual part number is located on the lower left corner of the front cover.*

# IMPORTANT SAFETY INSTRUCTIONS

**When using this machine, basic precaution  
must always be followed, including the following:**

**READ ALL INSTRUCTIONS BEFORE USING THIS MACHINE.**

**⚠ WARNING:** To reduce the risk of fire, electric shock, or injury:

Use only indoors. Do not use outdoors or expose to rain.

Use only as described in this manual. Use only manufacturer's recommended components and attachments.

If the machine is not working properly, has been dropped, damaged, left outdoors, or dropped into water, return it to an authorized service center.

Do not operate the machine with any openings blocked. Keep openings free of debris that may reduce airflow.

Machine can cause a fire when operating near flammable vapors or materials. Do not operate this machine near flammable fluids, dust or vapors.

This machine is suitable for commercial use, for example in hotels, schools, hospitals, factories, shops and offices for more than normal housekeeping purposes.

Maintenance and repairs must be done by qualified personnel.

During operation, attention shall be paid to other persons, especially children.

The machine shall only be operated by instructed and authorized persons.

When leaving unattended, unplug the machine.

Do not handle the plug or machine with wet hands.

Do not unplug machine by pulling on cord. To unplug, grasp the plug, not the cord.

Do not use with damaged cord or plug. Follow all instructions in this manual concerning grounding the machine.

Do not pull or carry by cord, use cord as a handle, close a door on cord, or pull cord around sharp edges or corners.

Do not pull/run machine over cord. Keep cord away from heated surfaces.

Connect to a properly grounded outlet. See Grounding Instructions.

If the supply cord is damaged it must be replaced by a special cord from an authorized service agent.

Unplug before cleaning or servicing.

Operational hazard may occur when running the machine over the supply cord.

This appliance has been designed for use with pads specified by the manufacturer. The fitting of other pads may affect its safety.

This machine is for dry use only and shall not be used or stored outdoors in wet conditions

Moving Parts - To reduce the risk of injury, unplug before servicing.

## READ AND SAVE THESE INSTRUCTIONS

## **IMPORTANTES MESURES DE SÉCURITÉ**

**L'utilisation d'un appareil électrique demande certaines précautions:  
LIRE TOUTES LES INSTRUCTIONS AVANT DE FAIRE FONCTIONNER (CET  
APPAREIL).**

**Pour réduire les risques d'incendie, de chocs électriques, ou de blessures.**

N'utiliser cette machine qu'en intérieur. Ne jamais l'utiliser à l'extérieur ou dans la pluie.

N'utiliser cette machine que comme décrit dans le présent manuel. N'utiliser que les composants et les accessoires conseillés par le fabricant.

Lorsque la machine ne fonctionnant pas correctement, a fait l'objet d'une chute ou d'une détérioration, a été laissée à l'extérieur, est tombée dans l'eau, la retourner au centre de service agréé.

Ne pas opérer la machine lorsque les conduits de ventilation sont bloquées. Débarrasser les débris des conduits, car ils peuvent réduire l'écoulement d'air.

Cette machine peut provoquer un incendie lorsqu'elle est utilisée près de vapeurs ou de matériaux inflammables. Ne pas l'utiliser près de liquides, de poussières ou de vapeurs inflammables.

Cette machine est destinée à un usage commercial. Elle est recommandée davantage pour les domaines hôtelier, scolaire, hospitalier, industriel ou pour les bureaux, les chaînes de magasin, que pour un usage domestique normal.

L'entretien et les réparations de la machine doivent être effectuées par un personnel qualifié.

Durant la manoeuvre de la machine, prendre garde aux personnes environnantes et notamment aux enfants.

Cette machine ne doit être manoeuvrée que par un personnel expérimenté et qualifié.

Lorsque vous laissez la machine sans surveillance, débranchez-la.

Ne pas toucher la fiche ou l'appareil lorsque vos mains sont humides.

Ne pas débrancher en tirant sur le cordon. Tirer plutôt la fiche.

Ne pas utiliser si le cordon ou la fiche est endommagé

Ne pas tirer soulever ou traîner l'appareil par le cordon. Ne pas utiliser le cordon comme une poignée, le coincer dans l'embrasure d'une porte ou l'appuyer contre des arêtes vives ou des coins.

Ne pas faire rouler l'appareil sur le cordon. Garder le cordon à l'écart des surfaces chaudes.

Cet appareil ne doit être connecter qu'à des prises ayant une sortie de terre. Se reporter aux instructions de mise à la terre.

Si le cordon d'alimentation est endommagé, il doit être remplacé par un cordon spécial d'un agent d'entretien autorisé.

Débranchez la machine avant de la nettoyer ou la réparer.

Un risque opérationnel est probable lors du fonctionnement de la machine avec une surcharge du cordon d'alimentation.

Cet appareil a été conçu pour être utilisé avec des coussins protecteurs spécifiés par le fabricant. L'utilisation d'autres coussins protecteurs peut affecter sa sécurité.

Cette machine est faite pour un usage à sec seulement et ne doit pas être utilisée ou rangée à l'extérieur dans des conditions humides.

Pièces Mobiles - Afin de réduire le risqué de blessure, débranchez avant de procéder à l'entretien. Utilisez à l'intérieur uniquement.

## **CONSERVER CES INSTRUCTIONS**

The following symbols are used throughout this guide as indicated in their descriptions:

## **HAZARD INTENSITY LEVEL**

There are three levels of hazard intensity identified by signal words -**WARNING** and **CAUTION** and **FOR SAFETY**. The level of hazard intensity is determined by the following definitions:

### **⚠ WARNING:**

**WARNING** - Hazards or unsafe practices which COULD result in severe personal injury or death.

### **⚠ CAUTION:**

**CAUTION** - Hazards or unsafe practices which could result in minor personal injury or product or property damage.

**FOR SAFETY: To Identify actions which must be followed for safe operation of equipment.**

Report machine damage or faulty operation immediately. Do not use the machine if it is not in proper operating condition. Following is information that signals some potentially dangerous conditions to the operator or the equipment. Read this information carefully. Know when these conditions can exist. Locate all safety devices on the machine. Please take the necessary steps to train the machine operating personnel.

**FOR SAFETY:**

**DO NOT OPERATE MACHINE:**

Unless Trained and Authorized.

Unless Operation Guide is Read and understood.

In Flammable or Explosive areas.

In areas with possible falling objects.

**WHEN SERVICING MACHINE:**

Avoid moving parts. Do not wear loose clothing; jackets, shirts, or sleeves when working on the machine. Use only manufacturer approved replacement parts

## **Safety**

---

Les symboles ci-dessous sont utilisés à travers ce manuel comme illustré dans leurs descriptions :

### DEGRÉS DE RISQUES EN CAS DE DANGER

Il existe trois degrés de risques identifiés par les termes signalétiques -AVERTISSEMENT et ATTENTION et POUR VOTRE SÉCURITÉ. Le degré de risque est défini de la manière suivante :

#### **⚠ AVERTISSEMENT:**

Dangers ou méthodes dangereuses qui POURRAIENT provoquer de graves blessures ou entraîner la mort.

#### **⚠ ATTENTION:**

Dangers ou méthodes dangereuses qui pourraient provoquer des blessures légères ou une détérioration du produit ou des biens immobiliers.

**POUR VOTRE SÉCURITÉ :** ce signe permet d'identifier les mesures de précaution à prendre pour assurer un bon fonctionnement du matériel.

Rendre compte immédiatement d'une défaillance ou d'une détérioration de la machine. Ne pas utiliser la machine si celle-ci ne fonctionne pas correctement. Lire soigneusement les informations ci-dessous signalant certains dangers potentiels pour l'opérateur de la machine. L'opérateur doit être absolument au courant de ces dangers potentiels. Localiser tous les dispositifs de sécurité sur la machine. Il est conseillé de prendre les mesures nécessaires pour former le personnel opérateur.

**POUR VOTRE SÉCURITÉ :**

**NE PAS MANOEUVRER LA MACHINE :**

Lorsqu'on n'est pas expérimenté ou qualifié.

Lorsque le guide d'utilisation n'est pas été lu ou compris.

Dans des zones inflammables ou explosives.

Dans des zones où des objets peuvent tomber.

**LORS DE L'ENTRETIEN DE LA MACHINE :**

Éviter les parties amovibles. Ne pas porter de vêtements amples, tels que des vestes, des chemises ou des vêtements avec manches lors de l'utilisation de la machine. Utiliser les pièces détachées homologuées.

**GROUNDING INSTRUCTIONS 120V**

**THIS PRODUCT IS FOR COMMERCIAL USE ONLY ELECTRICAL:**

In the USA this machine operates on a 15 amp nominal 120V, 60 hz, A.C. power circuit. The amp, hertz, and voltage are listed on the data label found on each machine. Using voltages above or below those indicated on the data label will cause serious damage to the motors.

**GROUNDING INSTRUCTIONS:**

This appliance must be grounded. If it should malfunction or break down, grounding provides a path of least resistance for electric current to reduce the risk of electric shock. This appliance is equipped with a cord having an equipment-grounding conductor and grounding plug. The plug must be inserted into an appropriate outlet that is properly installed and grounded in accordance with all local codes and ordinances.

This appliance is for use on a nominal 120-volt circuit, and has a grounded plug that looks like the plug in "Fig. A". A temporary adaptor that looks like the adaptor in "Fig. C" may be used to connect this plug to a 2-pole receptacle as shown in "Fig. B", if a properly grounded outlet is not available. The temporary adaptor should be used only until a properly grounded outlet (Fig. A) can be installed by a qualified electrician. The green colored rigid ear, lug, or the like extending from the adaptor must be connected to a permanent ground such as a properly grounded outlet box cover. Whenever the adaptor is used, it must be held in place by a metal screw.

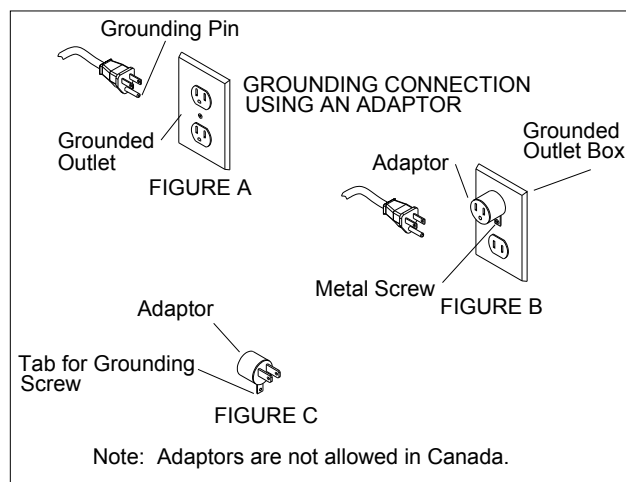

**⚠ WARNING:**

Improper connection of the equipment-grounding conductor can result in a risk of electric shock. Check with a qualified electrician or service person if you are in doubt as to whether the outlet is properly grounded. Do not modify the plug provided with the appliance - if it will not fit the outlet, have a proper outlet installed by a qualified electrician.

**⚠ AVERTISSEMENT:**

Le raccordement incorrect du conducteur de terre d'équipement peut entraîner des risques d'électrocution. Vérifiez auprès d'un électricien qualifié ou d'un responsable de l'entretien si vous avez quelque doute que ce soit quant au raccordement à la terre de votre prise murale. Ne modifiez pas la fiche fournie avec l'appareil: si elle ne correspond pas à la prise murale, faites installer une prise adéquate par un électricien qualifié.

## Safety Labels

### SAFETY LABEL LOCATION

These drawings indicate the location of safety labels on the Machine. If, at any time, the labels become illegible contact your authorized representative for prompt replacement.

### EMPLACEMENT DE L'ÉTIQUETTE DE SÉCURITÉ

REMARQUE : Ces dessins indiquent l'emplacement des étiquettes de sécurité sur la machine. Si, à tout moment, les étiquettes deviennent illisibles, contactez votre représentant autorisé pour un remplacement rapide.

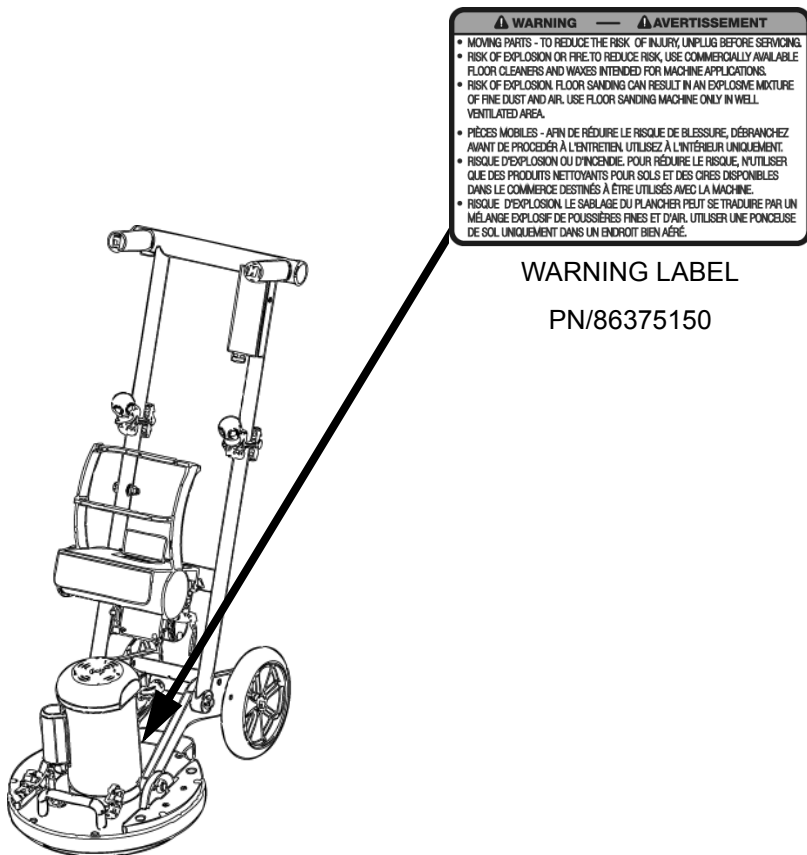

ITEM	MEASURE
Motor	1HP, 100-240V/50-60Hz, 6 amps (50Hz)/11amp (60Hz)
RPM	1725 (60Hz)/1400 (50Hz)
Base diameter	17"/43 cm
Orbital diameter	3/8" (9.5 mm)
Weight	82 Lbs./37 kg Basic /102 Lbs./46 kg Deluxe
Height	48" (122 cm)
Compact size for transport and storage	30" (76 cm)
Wheels	10"/25 cm Diameter, resistant to chemicals
Length	29"

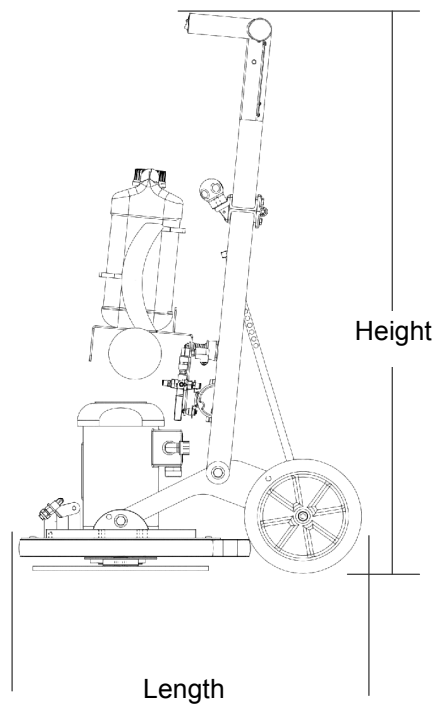
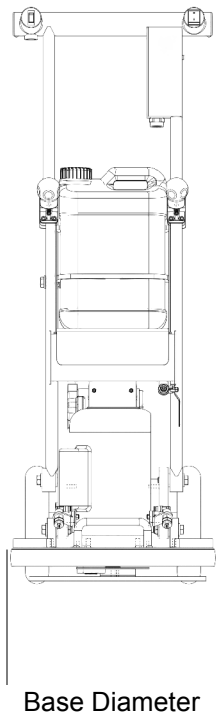



## Unpacking and Initial Operations

Open the shipping box on both sides, remove the packaging material and roll the machine out of the box.

Put the handle in an upright position.

Lift the round screw knobs up and over the top latch bracket and turn clockwise to lock properly.



Fill the water bottle with water. You can add a cleaning solution of your choice in the prescribed mixing ratio.

Place the filled water bottle close to the machine on the floor. Insert the filter into the water tank.

Make sure that the filter reaches the bottom of the bottle.



To insert and remove the water bottle in and out of the cage holder, insert or remove at an angle on the top hoop of the cage holder.



## Operation

### Pre-Run Inspection

Before each use inspect the accessory such as the pad driver for cracks, tears or excess wear. If the machine or accessory is dropped, inspect for damage to install an undamaged accessory.

Repair the damaged machine before the next application.

When inserting the bottle, push the container down until it rests firmly.



Choose a pad for the appropriate application. Place the pad in front of the machine on the floor and center the driver plate on the pad.

To place the driver plate on the pad, position the handle in a lower position.



Lift the machine until the wheels slightly come off the ground and push slowly forward until the machine base tilts towards the ground.



**⚠ CAUTION:**

Make sure you put the wheels back on the ground in time, to avoid the base from falling on the ground. This might cause damage!

**⚠ ATTENTION:**

Assurez-vous de toujours garder les roues arrière sur le sol, pour éviter que la base ne tombe sur le sol. Cela pourrait causer des dommages!



Now you are able to control the base and place it carefully on the pad

It's not necessary to center the pad exactly. Visual judgment is enough.

Take the power cable that comes with the machine, connect it to its counterpart which is located on the upper handle.

Simply push and twist lock power cables together, clockwise.

Firmly insert so that the black rubber ring disappears into the female coupler.

You can now plug the power cord plug into the outlet.

**⚠ WARNING:**

Never plug the power cord into the outlet before you plug the power cable to the machine!

**⚠ ATTENTION:**

Ne jamais brancher le cordon d'alimentation dans la prise avant de brancher le câble d'alimentation de l'appareil!

## Operation

### Pump

For priming the pump system for the first time, put the yellow lever, which is located on the left side of the machine in a vertical position



Hold down the black spray button on the right end of the handle for about 30 seconds until the pump is working at its full capacity.



This priming procedure should be repeated after every change of the water tank. For standard priming 10 seconds is usually sufficient.

By adjusting the yellow lever you can vary the spray pressure. The further you move the lever counter-clockwise upwards, the higher the water pressure. A horizontal position means maximum water output at maximum pressure.



Adjust the spray jets on the machine base to the desired position. For most floor cleaning applications adjust the spray jets so that they spray about 6 inches (15 cm) in front of the base.

Set the handle position to the desired height by pulling and releasing the black knob with the left hand.

While holding the black knob out, raise or lower the handle frame with your right hand.

To fix the handle frame into place, release the black knob so that it locks firmly into one of the holes provided.



To turn the machine on, press the power button on the end of the left handle.

Position "0" is off and position "1" is on.



### **! CAUTION:**

Make sure a suitable pad or brush is mounted before starting the machine. The immediate contact of the floor and driver plate without a pad can lead to serious damage of the floor and/or the machine.

### **! ATTENTION:**

Assurez-vous qu'une brosse ou un tampon adéquat est installé avant de démarrer l'appareil. Le contact immédiat avec la chaussée et la plaque d'entraînement sans tampon peut provoquer de graves dommages au sol ou à l'appareil.

## Operation

---

### Process of Cleaning

For effective floor cleaning, move the machine forward and backwards.

We recommend you to wet the floor as you move the machine forward, releasing the spray button when you move the machine backwards.

To increase the pressure and cleaning effect on certain floors like tile and grout, you can lift the machine frame up, raising the wheels off the ground. When lifting the wheels off the ground the full weight of the machine lies on the machine base.

#### **⚠ CAUTION:**

Make sure the surface to be cleaned is not damaged by the increase in pressure.

#### **⚠ AVERTISSEMENT:**

Assurez-vous que la surface à nettoyer n'est pas endommagée par l'augmentation de la pression.

Omit this measure on very sensitive floors.

### End of the Application

Turn off the machine by putting the on/off switch to "O".

If you used a cleaning solution, rinse the pump system with clear water. Install a bottle filled with clear water in the cage holder. If you do not have an open area to spray and rinse the pump, we recommend placing an absorbent pad on the floor in front of the spray jets and directly spray onto it. Press and hold down the spray button until the water is totally clear.

#### **⚠ CAUTION:**

Omitting this rinsing process can lead to internal hose, filter, and/or pump damage.

#### **⚠ ATTENTION:**

Omettre cette opération de rinçage peut se traduire par des dommages au tuyau interne, au filtre ou à la pompe.

## Storage

To store the base in the upright position, press down the handle frame with the right hand and lift up the base with the left hand by grabbing the base handle.



The machine base should now rest on the black bumper foot, located at the back of the bumper. To avoid damage to the handle frame, DO NOT lay the machine frame on the floor as done with other traditional cleaning equipment.

Remove the pad from the driver plate by pulling it down firmly.

Put the machine frame in an upright position by pulling the black knob with the left hand and move the handle frame upwards with the right hand. The black knob should lock firmly in the top hole.



### **!WARNING:**

Always remove the power cord from the electrical outlet before disconnecting it from the machine

### **!ATTENTION:**

!Retirez toujours le cordon d'alimentation de la prise électrique avant de déconnecter l'appareil!

To allow an easy transportation of the machine, remove the water bottle and the weight kit if used.

To easily roll the machine, create a leverage effect by pushing your foot on the back wheel axle and pull the handle towards your body. The machine can be moved similar to a dolly now.

Always store with the base in the upright position.

For storing in tight spaces, we recommend that you fold down the handle frame. Open the round screw knobs on the upper latch brackets by turning them counter-clockwise.

Fold down the loosened screw caps. The handle can now be folded down

## Operation

### Lifting and Carrying

If you do not have a ramp, we recommend that you lift the machine at all times with two people in and out of a vehicle.

Put the firmly locked handle into a lowered position. Make sure that the machine base rests on a pad, so that the Velcro surface of the driver plate does not get damaged or hooked onto a carpeted surface.

Grip the machine from each side as shown.

When lifting the machine in or out of the vehicle, set the wheels down first and then the machine base.



### **! WARNING:**

Make sure not to grip too close to the machine base. If the base should flip upwards it can cause serious hand injuries.

### **! ATTENTION:**

Veillez à ne pas serrer trop près de la base de l'appareil, car si la base se retournerait vers le haut, cela pourrait causer des graves blessures à la main.

Make sure you lift the machine with a back-friendly posture.

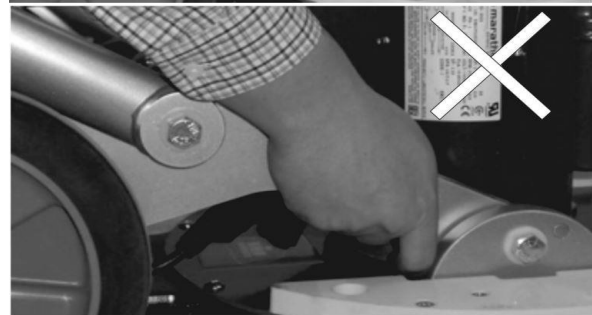

To save space, remove the star-shaped screw caps and fold down the handle and place the frame in an upright position.

To eliminate the machine from rolling or sliding during transport, lower the frame as far down as possible until it touches the wheels. The frame acts as a brake, preventing uncontrolled movements. This form of transportation requires sufficient space in a vehicle.



## Weight Kit Installation

The total weight of the weight kit is 40 lbs.

Put the weights on top of the white mounting plates located on the sides of the machine base.

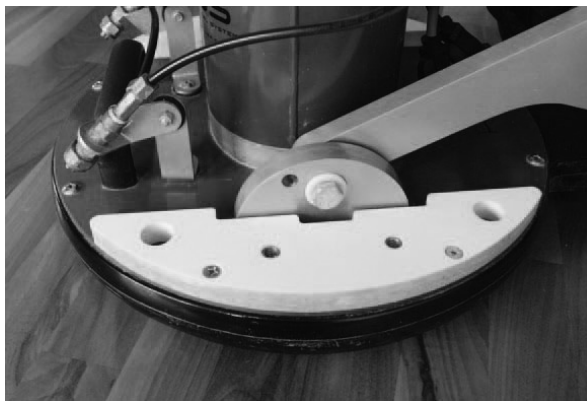

Put the four screws into the holes provided on the weight plates and fasten by turning clockwise.

Once the screws have threaded at least 5 full turns, tighten the wing nuts by turning them clockwise, until the weights fit securely to the base.

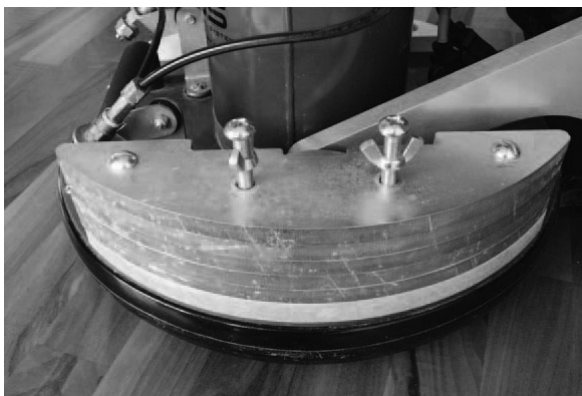

### **! CAUTION:**

Make sure that the weights are securely attached to the base. Loose weights can cause serious damage.

### **! ATTENTION:**

Assurez-vous que tous les poids sont solidement attachés à la base. Les poids lâches peuvent causer de graves dommages.

For storage and transport we recommend removing the weight kit. The machine can be transported more easily without the weights.

## Operation

---

### Brush Installation

Put the machine base in an upright position, sitting on the foot of the bumper.

Remove the driver plate by removing the four countersink screws in the center of the plate using an electric screwdriver.

#### **! WARNING:**

It is important to only use a Number 3 Phillips head screwdriver bit. Smaller bit sizes can damage the screw heads and leave sharp edges, which can tear or snag the pads.

#### **! AVERTISSEMENT:**

Il est important de n'utiliser qu'un embout de tournevis Phillips numéro 3. Des embouts de tailles inférieures peuvent endommager les têtes de vis et laisser des arêtes vives, qui peuvent se déchirer ou accrocher les tampons.

Mount the brush with the same countersink screws used for mounting the driver plates.

*NOTE: Tighten the screws sufficiently to avoid disengagement of the brush from the machine during operation*

*NOTE: Serrez les vis suffisamment pour éviter le désengagement de la brosse pendant le fonctionnement l'appareil..*

To avoid stripping the screws do not over tighten. An electric screwdriver with a clutch will ensure that stripping will not occur.

### Changing the Water Bottle

To put the water bottle in the cage holder, place the bottle at an angle over the cage hoop. Push the bottle into the cage hoop so that you can push it without much effort into the cage hoop holder.

Push the bottle down until it rests firmly

To remove the water bottle from the cage holder, proceed in reverse order:

Pull the water bottle out of the holder, as soon as the bottom of the bottle hits the cage hoop, tilt the bottle and pull it up and out at an angle. Remove the bottle from the cage holder and place it next to the machine on the floor

To remove the cap and spray hose from the water bottle, unscrew the bottle cap counter clockwise. Remove the hose and the filter from the water bottle. Seal the water bottle with a separate cap provided if needed for storage.

To connect the cap and spray hose to the water bottle, proceed in reverse order.

Secure cap to bottle until firmly sealed.

## Attaching and Removing the Driver Plates

Put the machine base in an upright position, sitting on the foot of the bumper. Remove the driver plate by removing the four countersink screws in the center of the plate using an electric screwdriver.

### **! WARNING:**

It is important to only use a Number 3 Phillips head screwdriver bit as smaller bit sizes can damage the screw heads. Damaged screws can cause further damage.

### **! AVERTISSIMENT:**

Il est important de n'utiliser qu'un embout de tournevis Phillips numéro 3, car des tailles d'embouts inférieurs peuvent endommager les têtes de vis. Les vis endommagées peuvent causer d'autres dommages.

Attach a driver plate to the machine base by lining up the holes of the driver plate with the appropriate threads of the bearing retainer ring. It is recommended to align the threads of the bearing horizontally to the ground.

Put the four countersink screws through the holes of the driver plate and first screw them into the bearing retainer ring threads manually.

Then, tighten the screws with an electric screwdriver

*NOTE: Tighten the screws sufficiently to avoid disengagement of the driver plate from the machine base during operation. To avoid stripping the screws do not over tighten. An electric screwdriver with a clutch will ensure that stripping will not occur.*

*NOTE: Serrez les vis suffisamment pour éviter le désengagement de la plaque d'entraînement pendant le fonctionnement l'appareil. Pour éviter d'endommager les vis, ne les serrez pas trop. Un tournevis électrique avec embrayage veillera à ce qu'il y ait aucun endommagement.*

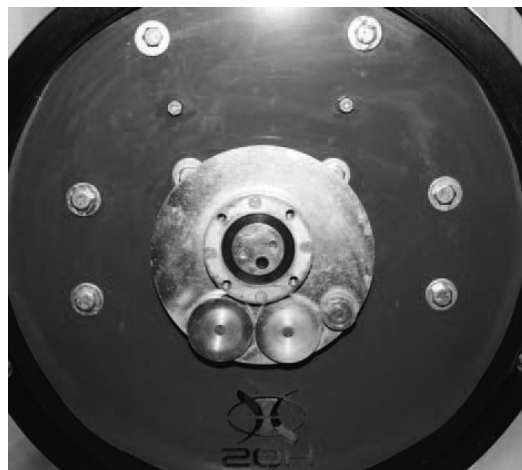

### Accessories And Applications

#### **⚠ WARNING:**

Never store the accessories in wet conditions. Keep the accessories away from extreme heat and from chemicals.

#### **⚠ AVERTISSIMENT:**

N'entreposez jamais les accessoires dans des endroits humides. Gardez les accessoires hors de la chaleur extrême et de produits chimiques.

### Driver Plates

#### **⚠ WARNING:**

Exclusively use designed driver plates only. The use of other driver plates will damage the machine and its mechanical action.

#### **⚠ AVERTISSIMENT:**

Utilisez exclusivement des plaques d'entraînement de fabricant. L'utilisation d'autres plaques d'entraînement endommagerait l'appareil et son action mécanique.

The driver plates are fastened on the machine base with four countersink screws.

### Standard Driver Plate

The standard driver plate (15" in diameter/38 cm) is supplied as standard. It is suitable for the use with all pads for textile and hard floor applications.

The pads can be easily attached and removed from the Velcro driver disc.

After frequent use, lint will stick to the Velcro surface of the driver plate, which hinders a secure attachment of the cleaning pads and will increase wear and tear to the pads.

Change the Velcro driver disc often as needed to avoid problems.

## Pads

### Absorbent Pads

The Absorbent pads are made of a cotton-polyester microfiber fabric. Because of their high percentage and quality of cotton, they are highly absorbent and are ideal for cleaning carpets as well as cleaning and drying wet or damp hard floors.

Wash the Absorbent pads before their first usage with regular laundry detergent and bleach in a washing machine.

*NOTE: Never dry the pads in a dryer.*

To clean the floor, center the driver plate on the Absorbent pad. Eye judgment is sufficient.

With a diameter of 21", the Absorbent pads are much larger than the driver base. This is intended and allows the cleaning of furniture legs, edges, and baseboards.

Wash the pads after each use in a washing machine. After the wash cycle, stack the pads in the moist condition. They are now ready for use. Don't dry the pads, as this might trap the dirt.

An Absorbent pad, used on both sides, cleans 100-1000 sq. ft (10-100 m<sup>2</sup>), depending on the level of soil.

The Absorbent pads can be washed and reused, if cared for appropriately, up to 100 times.

### Glider

The Gliders reduce the friction on textile surfaces. They are used to clean sensitive and long fiber carpets gently or to facilitate the handling of the machine on very rough carpets.

There are two types of gliders in different widths. The thin black glider is used on short-pile carpet, while the slightly thicker white glider is used for cleaning medium-length to long-fiber carpets.

The gliders are suitable for use with the Absorbent pads. Due to the Velcro surface, the gliders stick to the pads.

Attach the glider on the pad so that it is located between the floor and the pad. Place the glider on the floor, with the Velcro side facing up. Center the pad on top of the glider and place the driver plate on the pad.

### **WARNING:**

Make sure to always have the flat surface of the glider facing the floor. Never put the Velcro side on the carpet, as this might cause serious damage to the floor.

### **AVERTISSEMENT:**

Assurez-vous toujours que la surface plane du patin fait face au sol. Ne mettez jamais le côté Velcro sur le tapis, car cela pourrait causer de graves dommages au plancher.

## **Operation**

---

### **Carpet Pads**

The beige Carpet pads are made of a special blend of fibers and latex that allows the gentle cleaning of heavily soiled short-pile carpets as well as the scrubbing of hard floors.

Attach the Carpet pads by centering them onto the driver plate.

A Carpet pad, used on both sides, cleans an approximate area of 1000 -2000 sq. ft (100 to 200m<sup>2</sup>), depending on the floor type and the level of soil.

Rinse the Carpet pads after each use with clean water.

### **Chemical Free Stripping Pad**

Chemical Free Stripping Pads are made of a unique material impregnated with diamonds. They can be used for deep cleaning and to remove wax off of vinyl, VCT, linoleum, wood, safety tiles and more.

A Chemical Free Stripping Pad, used on both sides, cleans an approximate area of 1000-2000 sq. ft (100 to 200m<sup>2</sup>), depending on the floor type and the level of wax and soil.

Make sure to thoroughly rinse the Chemical Free Stripping Pad with clean water after each use.

## Multi-Purpose Brush

The bristles of the brush are made of high quality nylon. This unique brush design is ideal for cleaning tile and grout, concrete, rubber flooring and micro-porous surfaces such as porcelain and safety tiles, but can also be used for any other hard surfaces.

### **CAUTION:**

The use of the multi-purpose brush may splash in certain applications. Take appropriate measures or use a splash guard if necessary to prevent the wetting of walls and other obstacles.

### **ATTENTION:**

Dans le cadre de certaines applications, l'utilisation de la brosse à usages multiples peut éclabousser. Prenez les mesures appropriées ou utilisez le pare-éclaboussures si nécessaire pour empêcher de mouiller les murs et d'autres obstacles.

Rinse the brush as needed with clean water after each use.

Depending on usage and care, you can use the multi-purpose brush for many years.

**NOTE ON STORAGE:** Never store the multi-purpose brush with the bristles down. This can deform the bristles, damage the brush and reduce the cleaning performance.

You can bring deformed bristles back into their original form by heating them with a heat gun.

### **Application on different Floor Types**

#### **Carpet Cleaning**

Vacuum the carpet thoroughly before cleaning. Large dirt particles are removed, allowing the application to be more effective.

Depending on the level of soil and the nature of the carpet, select a suitable textile cleaning pad. Absorbent pads are suitable for all types of carpets, while Carpet pads are suitable in particular for the cleaning of heavily soiled commercial carpets.

Attach a Absorbent pad on the driver plate by laying the pad on the floor and centering the machine base over the pad.

For gentle cleaning on sensitive long-fiber carpets and for easy handling on rough carpets, use the Gliders.

Each section of the carpet should be moistened first by using the spray button when you move forward. The carpet should be cleaned by going forward and backwards two to three times, while only spraying on the first pass in order to keep the drying time low. Depending on the level of soil and the nature of the carpet, this process can be shortened or extended.

As required, carpets can be vacuumed again after cleaning.

#### **Cleaning Hard Floors**

Remove dust and coarse dirt from the surface before cleaning

Choose a suitable pad according to the application.

Place the driver plate on the pad by putting the pad on the floor and centering the machine base over it.

Each section of the surface should be cleaned by moving two to three times forward and backwards and adding water and cleaning solution as needed. Depending on the soil contamination and the floor type this process can be shortened or extended.

**Cleaning the machine:**

Clean the machine with a soft cloth and a neutral pH cleaner.

**Cleaning the spray system:**

Rinse the spray system after each application to prevent clogging of the hoses, filters and the pump system.

To rinse the spray system, install a bottle filled with clear water and place a Absorbent pad in front of the spray jets. Rinse the system by holding down the black spray button on the machine's handle for at least 30 seconds.

If the spray nozzles get clogged, remove the caps and soak the brass parts of the spray nozzles and filters in a degreasing solution (like acetone) for about 15 minutes.

If the spray nozzles are leaking, replace the filters

When assembling the nozzles, make sure that the nozzle holes are aligned horizontally to achieve a uniform spray pattern

**Changing the Velcro driver discs**

Remove the eight outer screws that fasten the Velcro disc on the driver plate. To save time, use an electric screw-driver with a #3 Phillips Head bit.

**⚠ WARNING:**

The Number #3 Phillips head bit is slightly larger than standard size. It is important that you are using a #3 Phillips Head bit, as smaller bits can damage the screw heads and produce sharp edges which can damage the cleaning pads.

**⚠ AVERTISSEMENT:**

L'embout de tournevis Phillips numéro 3 est légèrement plus grand que la taille standard. Il est important que vous utilisiez un embout de tournevis Phillips numéro 3, puisque des embouts de taille inférieure peuvent endommager les têtes de vis et laisser des arêtes vives, qui peuvent endommager les tampons de nettoyage.

Attach a new Velcro disc to the driver plate using the eight screws.

**⚠ WARNING:**

Make sure that the screws are very tight, not loose. If the screws are the slightest loose it can cause damage to the Velcro disc.

**⚠ AVERTISSEMENT:**

Assurez-vous que les vis sont bien serrées. Si les vis sont moindrement lâches, elles peuvent causer des dommages au disque Velcro.

Ensure that the four holes in the middle of the Velcro disc are aligned with the screws located on the driver plate. An exact alignment allows an easy removal and installation of the driver plate.

## **Maintenance**

### **Changing the filters**

If the spray jets become clogged or should leak, this is a sign that the filters must be changed.

To change the filters, open the spray jet caps by turning the caps with a suitable wrench counterclockwise. Fix the spray jet body with a wrench using the other hand for stabilization.

Remove the spray jet caps. The spray tip and the check ball valve filter can now be removed easily from the spray jet body.

Insert the new filter in the spray jet body housing, place the spray tip inside the cap, put the cap on the thread and turn clockwise to seal.

Seal the cap firmly by using the appropriate wrenches. The spray jets can now be operated as usual.

Make sure to align the slits of the spray jet tips in a horizontal plane to the floor to allow for an even spray pattern.

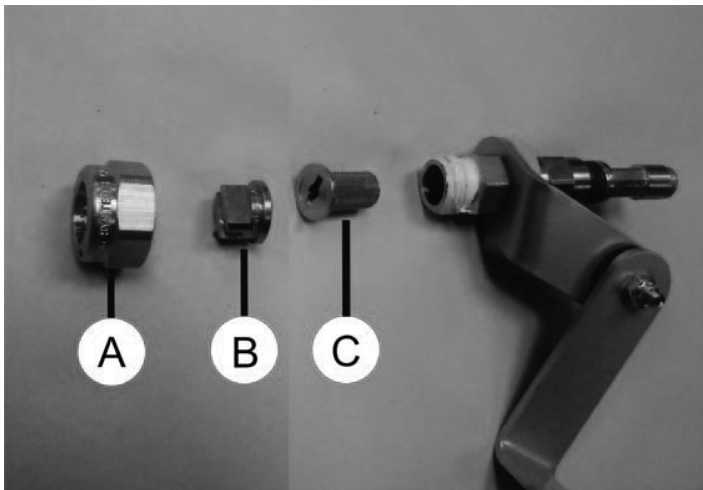

A: Cap

B: Spray Tip

C: Check Ball Valve Filter

*NOTE: Use all manufacturer accessories and recommended parts only for operating.*

The use of inappropriate driver plates, pads, brushes or weights can damage the machine and the floor.

Use only manufacturer recommended parts and pads or the warranty will be voided.

# PARTS

# Bottle Holder

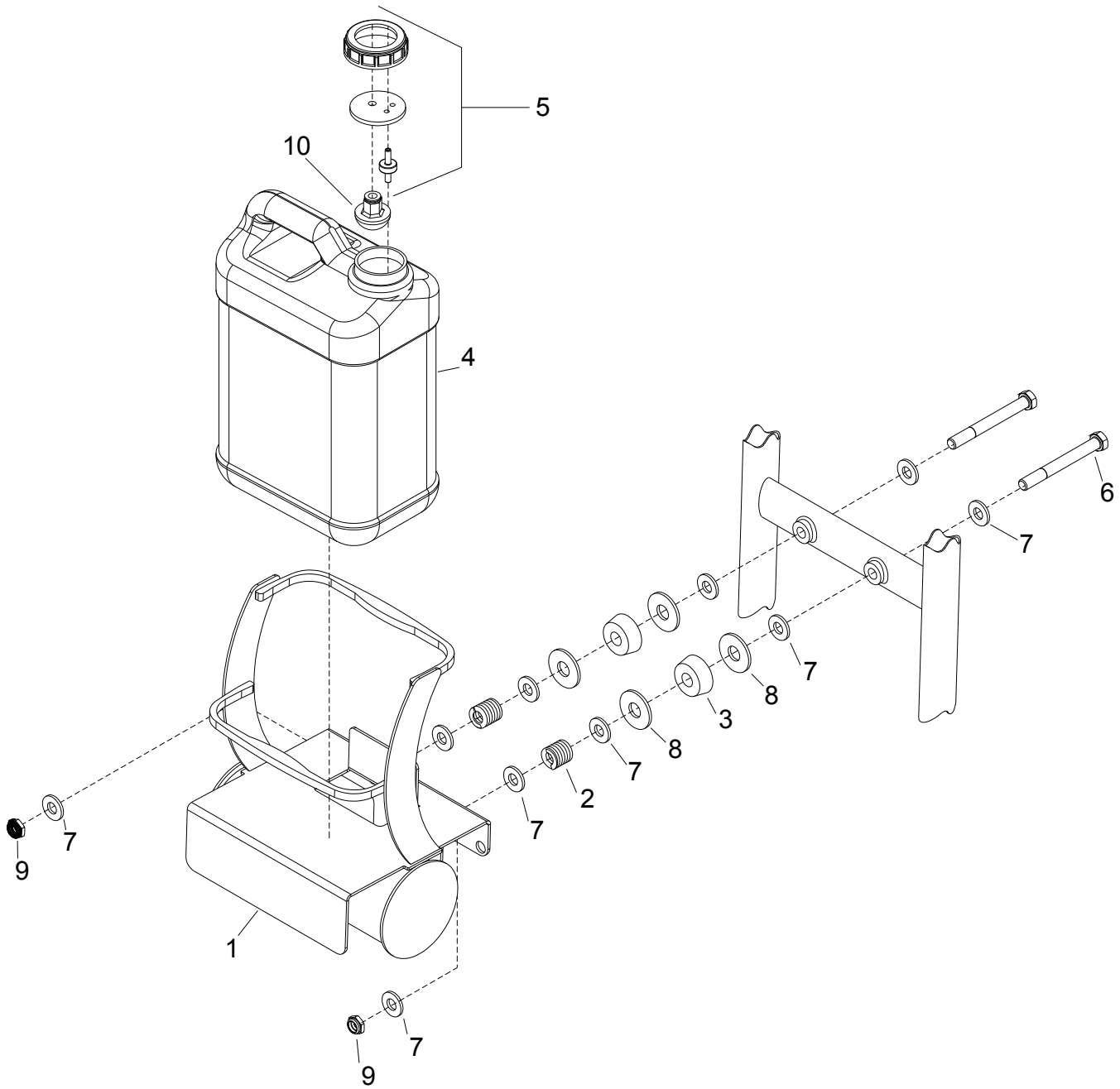

REF	PART NO.	QTY	DESCRIPTION	SERIAL NO. FROM	NOTES
1	86376430	1	CAGE ASSY, BOTTLE HOLDER		
2	86376440	2	SPRING, BOTTLE HOLDER		
3	86376450	2	DAMPNER, RUBBER		
4	86374720	1	BOTTLE, CARTRIDGE, 3 GAL		
5	86376460	1	BOTTLE CAP, ASSY		
6	86377010	2	SCREW, 1/2-13 X 4.38 HH STL ZNPLT		
7	86377020	10	WASHER, NYLON, CAGE		
8	86377030	4	WASHER, 5/8 X 1.75 X .134 FLT ZNPLT		
9	86005790	2	NUT, 1/2-13 HEXTHIN NYLOCK STL ZNPLT		
10	86377540	1	STRAINER, SOLUTION BOTTLE		

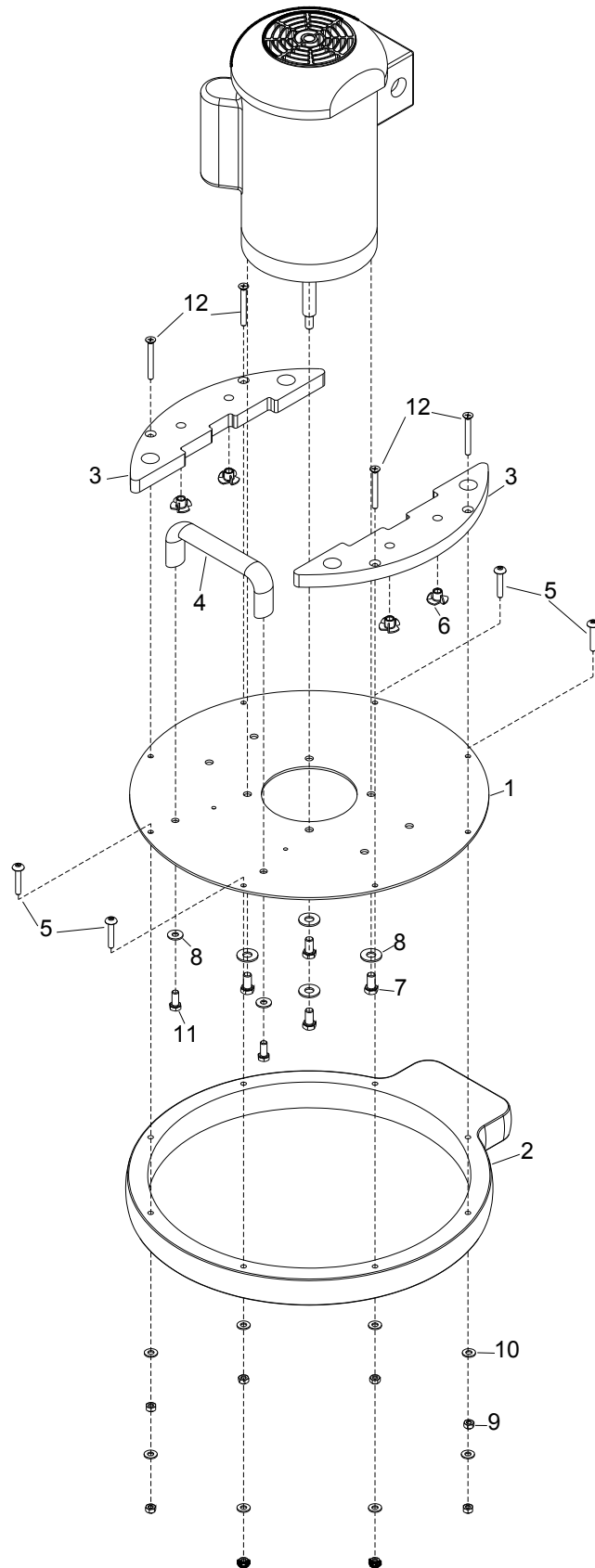

REF	PART NO.	QTY	DESCRIPTION	SERIAL NO. FROM	NOTES
1	86376500	1	PLATE, MOTOR MOUNT		
2	86376510	1	BUMPER SET		
3	86376520	2	PLATE, BASE, WEIGHT		
4	86376530	1	HANDLE, BASE		
5	86377290	4	SCREW, 1/4-20 x 1.5 PHTRH SS		
6	86377070	4	NUT 1/4-20 X .313 TEE 4 PRONG ZNPLT		
7	86377280	4	SCREW, 3/8-16 X .75 HH STL GRD8 YL ZNPLTT		
8	86279510	6	WASHER, 3/8 FLT		
9	86377100	8	NUT, 1/4-20 HEX LK STL ZNPLT		
10	86270330	8	WASHER, 1/4 X .625 STL ZNPLT		
11	86377120	2	SCREW, 5/16-18 X .75 HH STL ZNPLT		
12	86377060	4	SCREW, 1/4-20 X 2.25 PHFLH ZNPLT		

# Handle - Latch

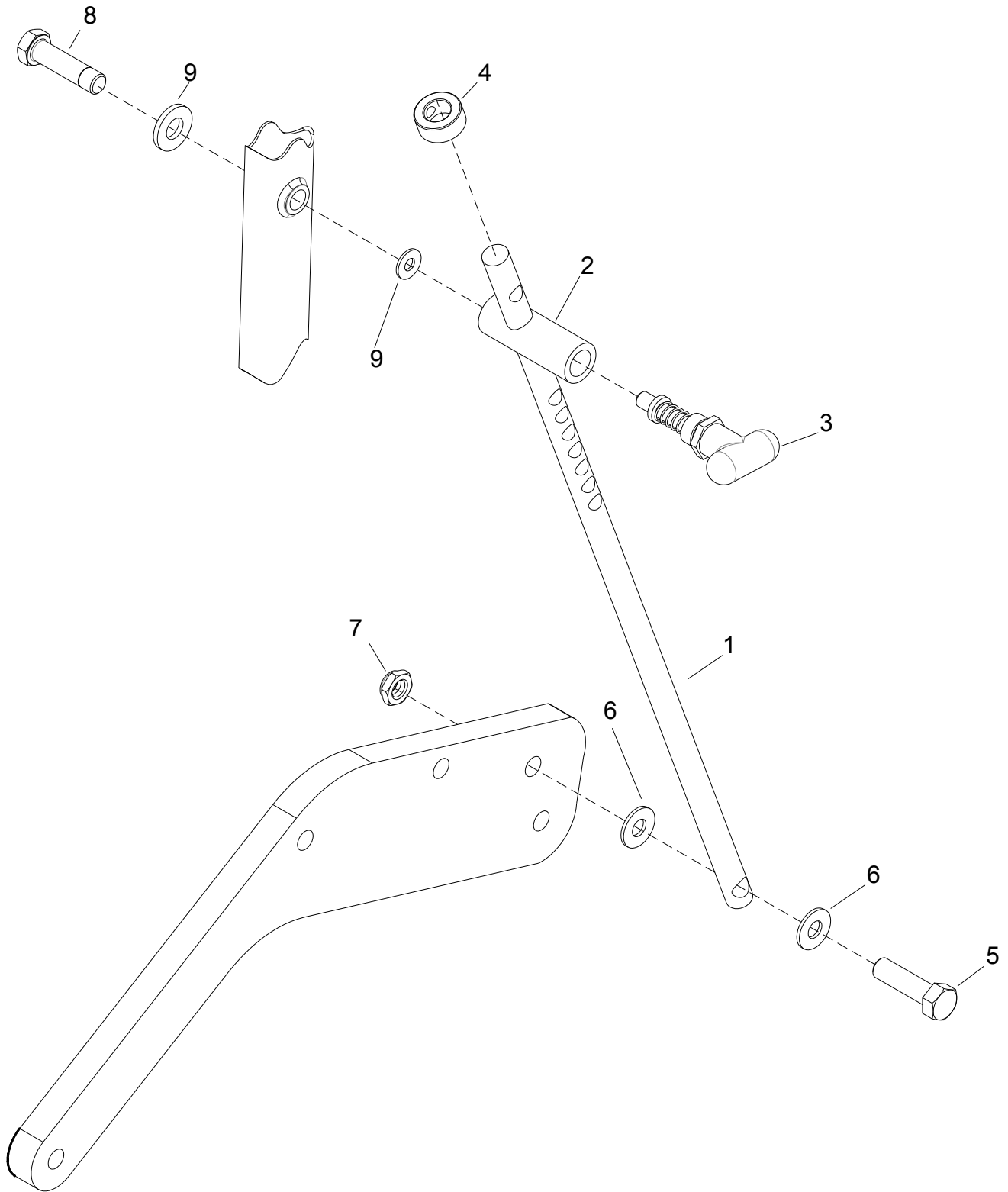

REF	PART NO.	QTY	DESCRIPTION	SERIAL NO. FROM	NOTES
1	86376390	1	ROD, HANDLE		
2	86376400	1	LATCH BODY PULL		
3	86376410	1	LATCH, PULL		
4	86376420	1	COLLAR, HANDLE LATCH		
5	86376960	1	SCREW, 1/2-13 X 1.75 HH STL ZNPLT		
6	86376970	2	WASHER, 1/2 LATCH NYL		
7	86005790	1	NUT, 1/2-13 HEXTHIN NYLOCK STL ZNPLT		
8	86376920	1	SCREW, 1/2-13 X 2 HH STL ZNPLT		
9	86377000	2	WASHER, 1/2 LATCH MOUNT NYL		

# Handle - Lower

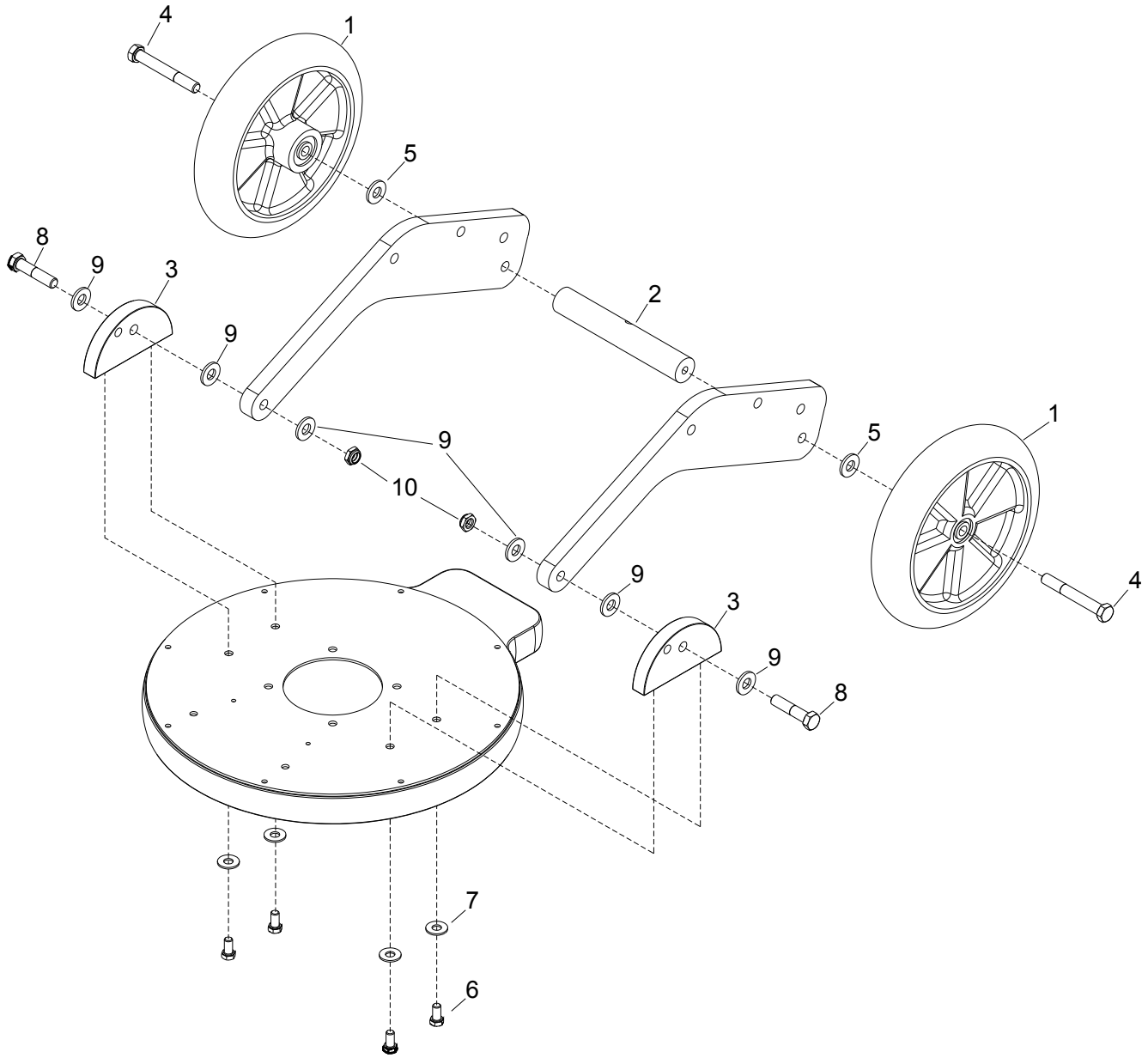

REF	PART NO.	QTY	DESCRIPTION	SERIAL NO. FROM	NOTES
1	86376360	2	WHEEL, 10"		
2	86376370	1	ROD, WHEEL		
3	86376380	2	EARS, HANDLE, BASE PLATE		
4	86376940	2	SCREW 1/2-13 X 3.75 HH STL ZNPLT		
5	86376950	2	WASHER, NYLON, WHEEL		
6	86377280	4	SCREW, 3/8-16 X .75 HH STL GRD8 YL ZNPLT		
7	86279510	4	WASHER, 3/8 FLT		
8	86377300	2	SCREW, 1/2-13 X 2.25 HH STL ZNPLT		
9	86377310	6	WASHER, NYLON, ARMS TO EAR		
10	86005790	2	NUT, 1/2-13 HEXTHIN NYLOCK STL ZNPLT		

## Handle - Middle

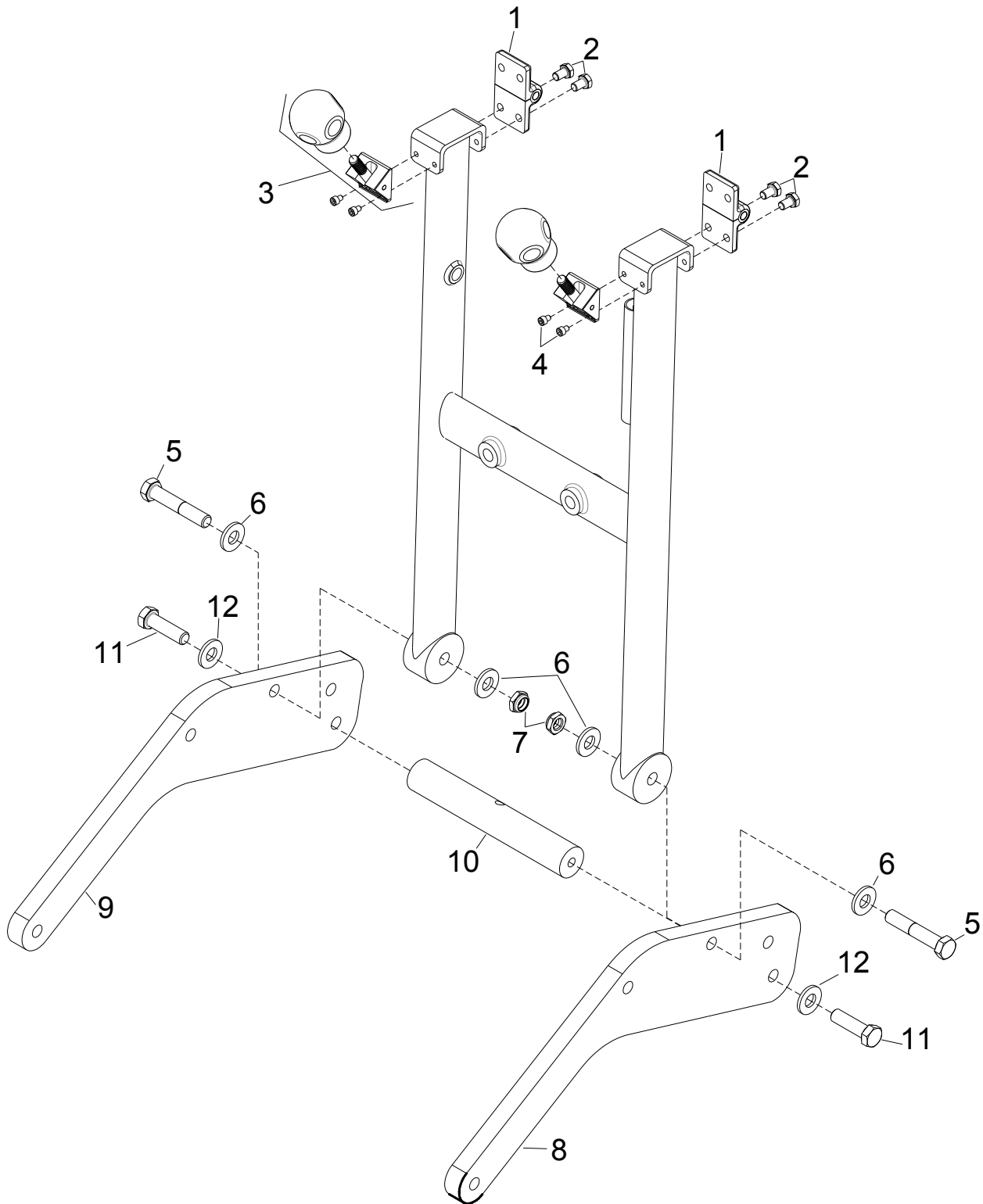

REF	PART NO.	QTY	DESCRIPTION	SERIAL NO. FROM	NOTES
1	86376280	2	HINGE, HANDLE		
2	86376350	8	SCREW, 5/16-24 X 1/2",HHMS, STL, ZNPLT		
3	86376290	2	LATCH, LOWER ASM, HANDLE		
4	86376870	4	SCREW, 10-32 X .25 SCHCS STL ZNPLT		
5	86376890	2	SCREW, 1/2-13 X 2.38 HH STL ZNPLT		
6	86376900	4	WASHER, NYLON		
7	86005790	2	NUT, 1/2-13 HEXTHIN NYLOCK STL ZNPLT		
8	86376310	1	PLATE, ARMS, LIFT, LH		
9	86376320	1	PLATE, ARMS, LIFT RH		
10	86376330	1	ROD, BRACE		
11	86376920	2	SCREW, 1/2-13 X 2 HH STL ZNPLT		
12	86376930	2	WASHER, NYLON, ARM SUPPORT		

# Handle - Upper

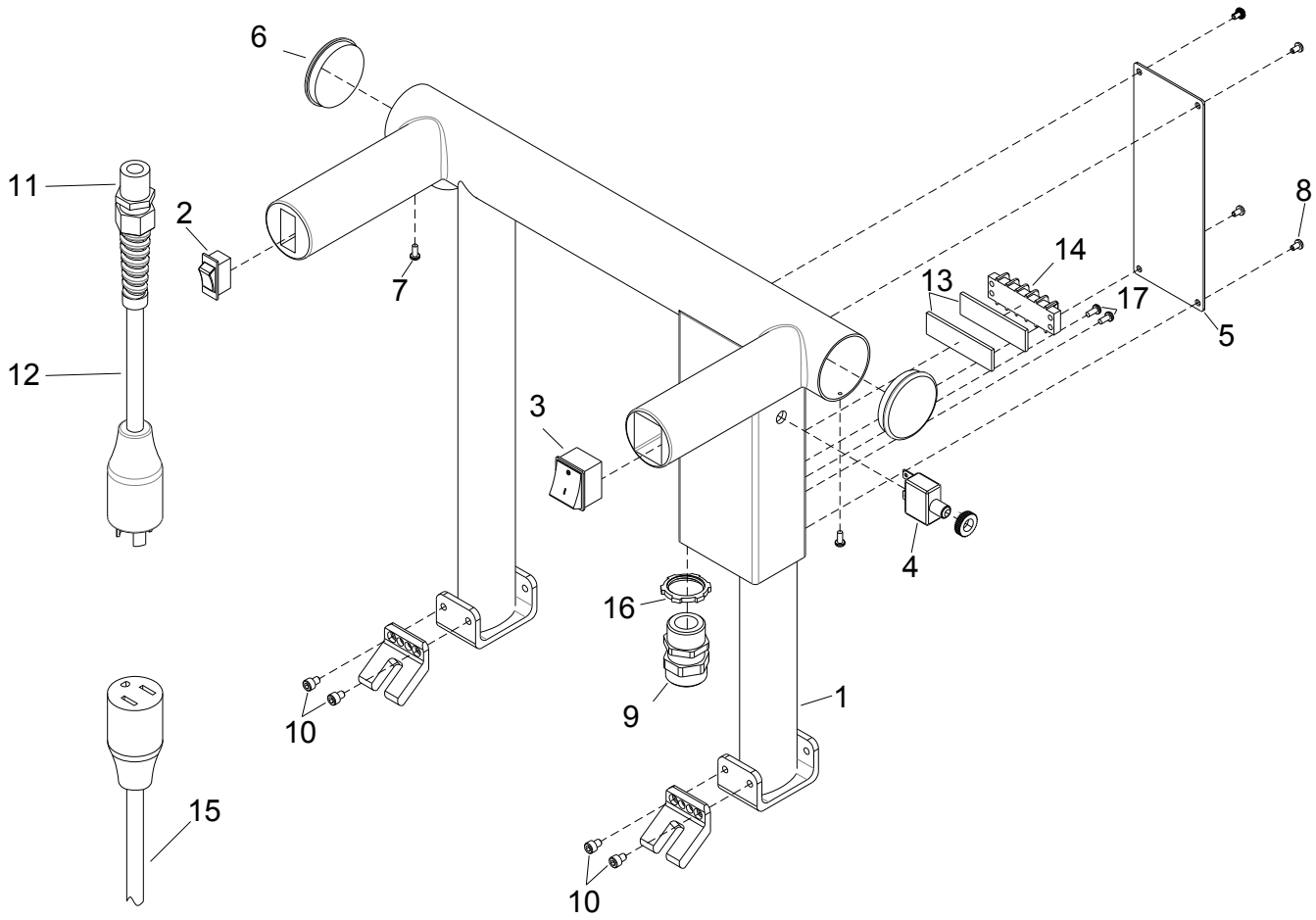

REF	PART NO.	QTY	DESCRIPTION	SERIAL NO. FROM	NOTES
1	86376150	1	HANDLE ASM, UPPER, W/ELEC BOX		
-	86377370	1	HARNESS, MAIN HANDLE		NOT SHOWN
2	86375130	1	SWITCH, DP, 2POS, ROCKER SPR		
-	86376250	1	HARNESS, SPRAYER SWITCH		NOT SHOWN
3	86375120	1	SWITCH, DP POS, ROCKER		
-	86376260	1	HARNESS, ON/OFF SWITCH		NOT SHOWN
4	86375140	1	BREAKER, 20A 125/250VAC 32VDC		
5	86376160	1	PLATE, COVER, ELECTRICAL BOX		
6	86376180	2	COVER, TUBE, HANDLE		
7	86376850	2	SCREW, 6-20 X .375 PHPNH STL ZNPLT		
8	86376860	4	SCREW, ELECT BOX		
9	86376190	1	STRAIN RELIEF, ELEC BOX		
10	86376870	4	SCREW, 10-32 X .25 SCHCS STL ZNPLT		
11	86376200	1	STRAIN RELIEF, POWER CORD		
12	86376210	1	POWER CORD, HANDLE		
13	86376230	1	VELCRO, TERMINAL SWITCH		
14	86376240	1	TERMINAL SWITCH		
15	86376220	1	POWER CORD, 50' 110V		
16	86377360	1	NUT, 1/2 CORD GRIP		
17	86377480	2	SCREW, 8-32 X .375 SLTDHH SS		

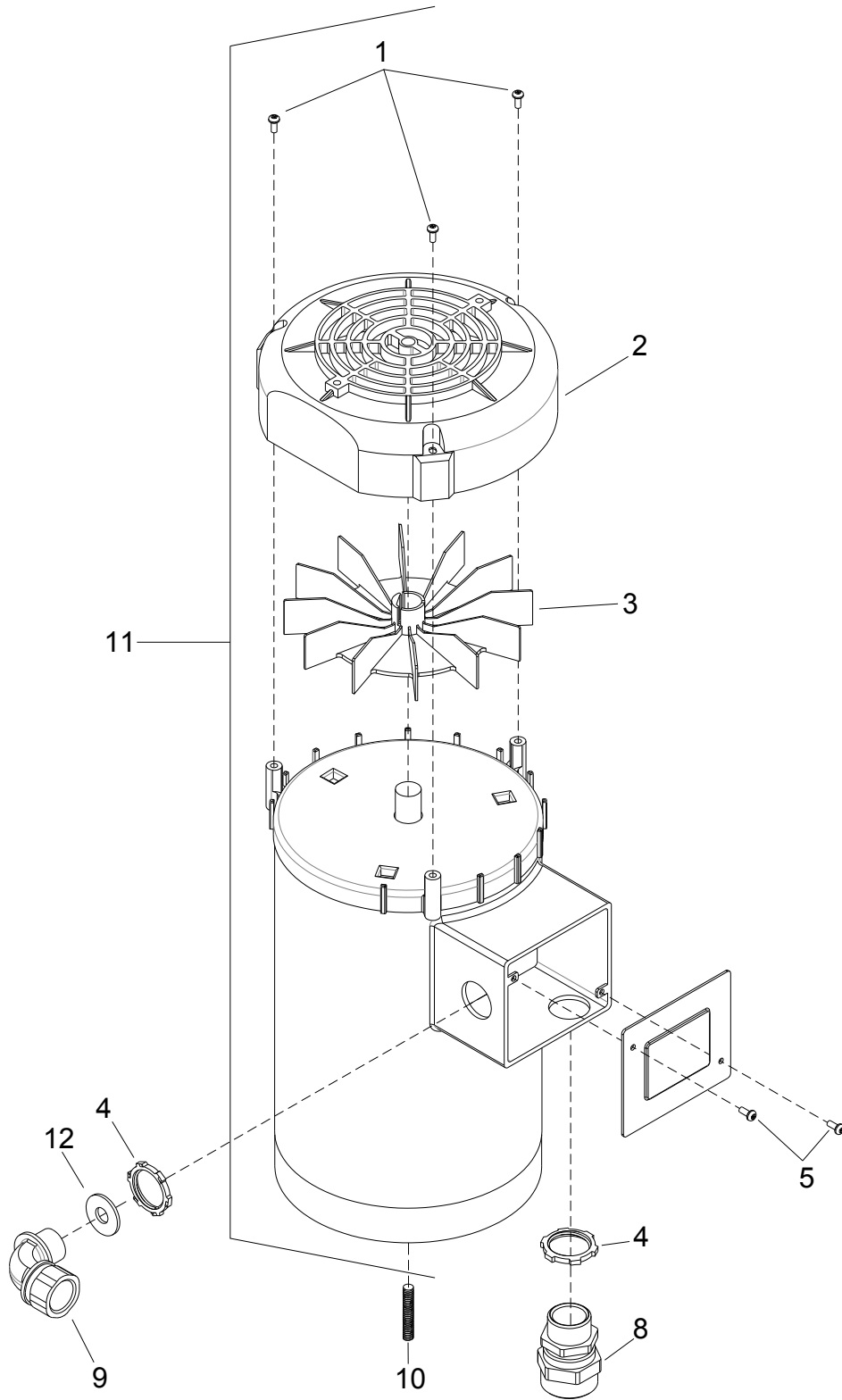

REF	PART NO.	QTY	DESCRIPTION	SERIAL NO. FROM	NOTES
1	86377400	3	SCREW, 10-32 X .25 SLTD HH STL ZNPLT		
2	86377410	1	COVER, FAN MOTOR		
3	86377420	1	FAN, MOTOR		
4	86377430	2	NUT, 3/4 CONDUIT		
5	86377440	2	SCREW, MOTOR LID		
6	86377450	1	CORD, BLUE PLUG, 100-120V		NOT SHOWN
7	86377460	1	CORD, BLACK PLUG, 100-120V		NOT SHOWN
8	86376540	1	CORD GRIP, 3/4", MOTOR		
9	86376550	1	CORD GRIP, 90 DEG, MOTOR		
10	86377510	1	SCREW, 3/8-24 X 1-1/2" SCH, SET, BLKOX		
11	86376490	1	MOTOR, 110/220V, 1750RPM		
12	86377500	1	WASHER, 7/8 X 1.25 DSP BLKOX		

# Nozzle

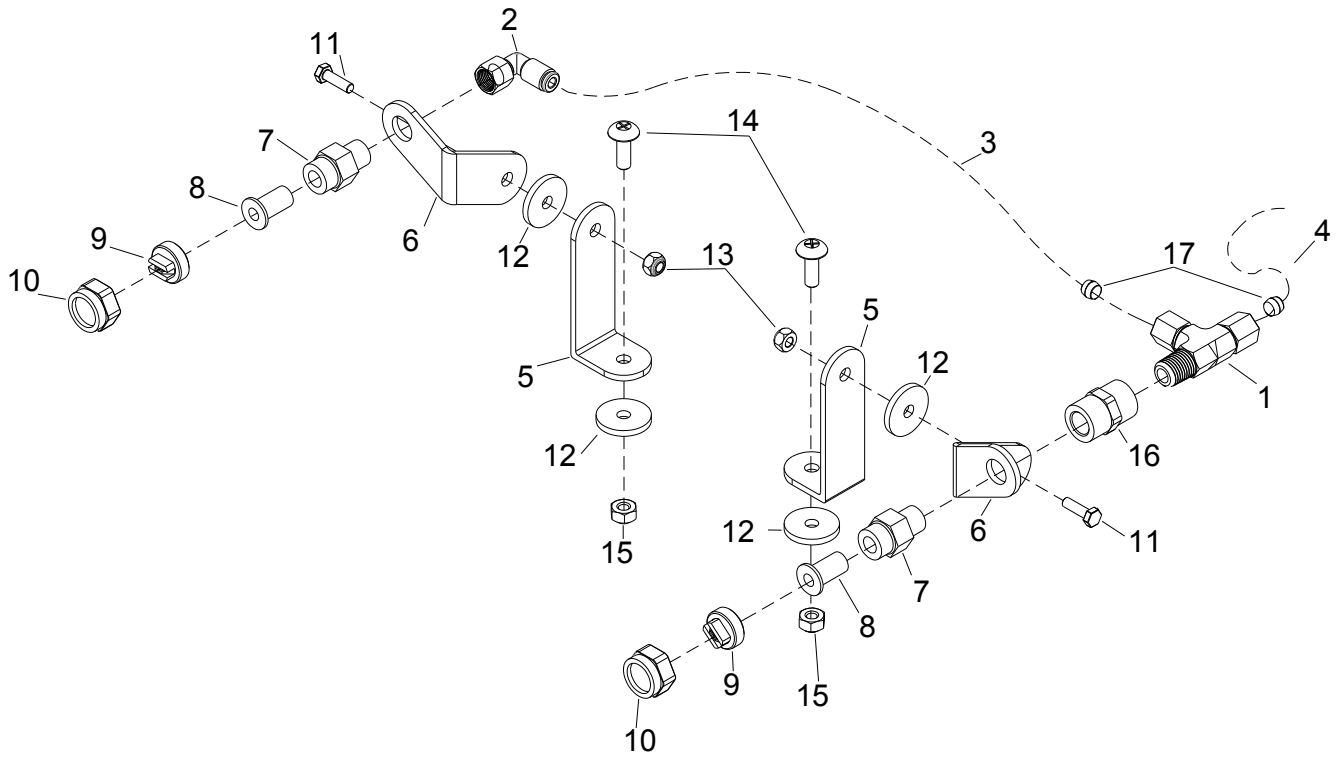

REF	PART NO.	QTY	DESCRIPTION	SERIAL NO. FROM	NOTES
1	86376750	1	FITTING, TEE, SPRAY NOZZLES		
2	86376760	1	FITTING, 90, SPRAY NOZZLES		
3	86376770	1	HOSE, SPRAY NOZZLES		
4	86376780	1	HOSE, SPRAY NOZZLES CAGE		
5	86376790	2	PLATE, ANGLE, NOZZLE BASE		
6	86376800	2	PLATE, ANGLE, NOZZLE		
7	86376810	1	COUPLER, FILTER		
8	86375100	2	STRAINER, CHECK VALVE		
9	86376820	2	NOZZLE, SPRAYER		
10	86376830	2	NOZZLE RETAINER		
11	86377220	2	SCREW, 10-32 X 3/4", HXUNS, ZNPLT		
12	86377230	2	WASHER, SPRAY JET ARM		
13	86005640	2	NUT, 10-32 HEX NYLOCK STL GR2 ZNPLT		
14	86277640	2	SCREW, 1/4-20 X .75 PHTRH SS		
15	86005640	2	NUT, 10-32 HEX NYLOCK STL GR2 ZNPLT		
16	86376840	1	COUPLER, NOZZLE BASE PLATE		
17	86377390	2	SLEEVE, COMPRESSION, CON		

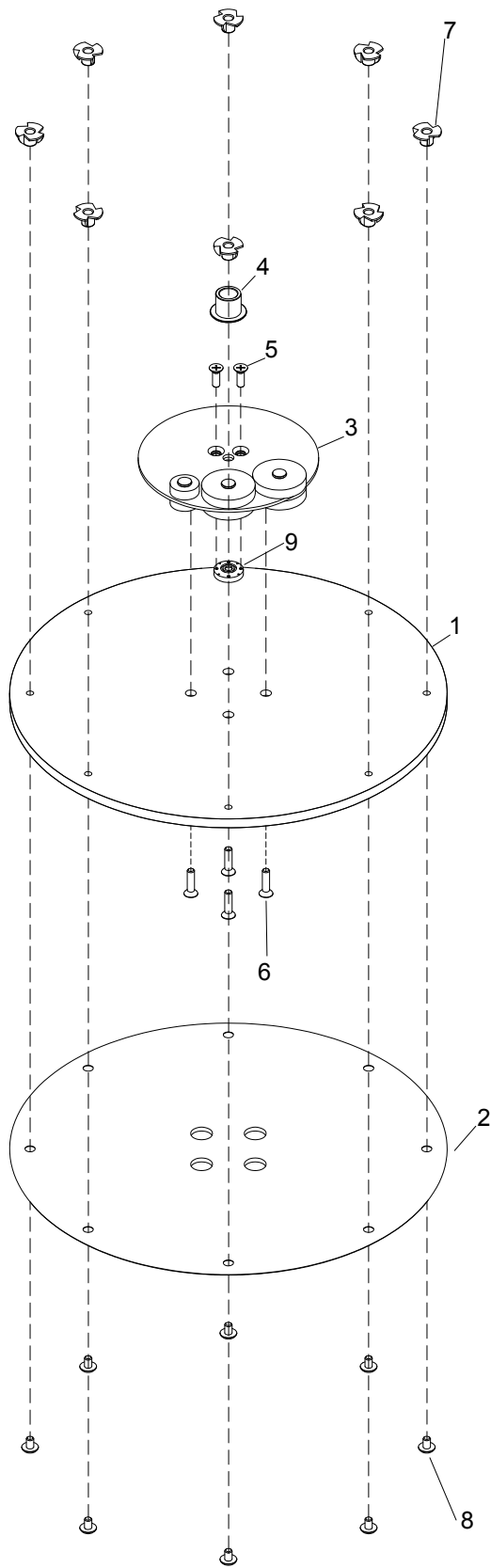

REF	PART NO.	QTY	DESCRIPTION	SERIAL NO. FROM	NOTES
1	86376570	1	DRIVER, DISK, 15"		
2	86376580	1	DRIVER, VELCRO PLATE, 15"		
3	86397750	1	ASSY, COUNTERWEIGHT, 17 DISK		INCLUDES #9
4	86377330	1	SHAFT SUPPORT		
5	86377160	2	SCREW, 1/4-20 X .75 PHFLHMS SS		
6	86377170	4	SCREW, 1/4-20 X 1 PHFLH SS		
7	86377070	8	NUT 1/4-20 X .313 TEE 4 PRONG ZNPLT		
8	86377470	8	SCREW, 1/4-20 X .375 PHTRH SS		
9	86375110	1	ASSY, BEARING, 17 DISK		

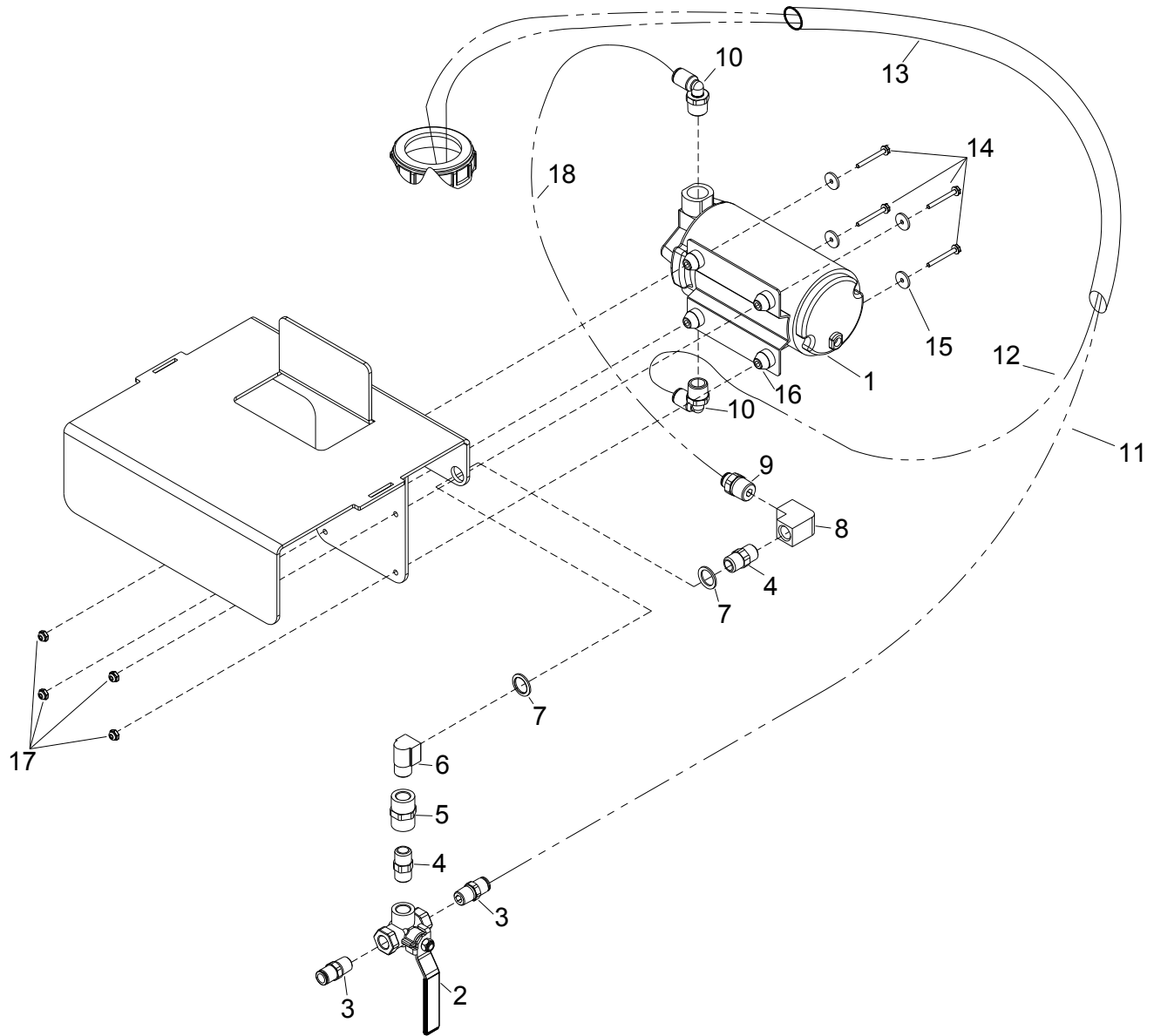

REF	PART NO.	QTY	DESCRIPTION	SERIAL NO. FROM	NOTES
1	86376610	1	PUMP, 90PSI, 120V		
2	86376620	1	VALVE, FLOW CONTROL, 3-WAY		
3	86376630	2	COUPLER, QD, FLOW CONTROL		
4	86376640	2	NIPPLE, 1/4", HEX		
5	86376650	1	COUPLER, FLOW CONTROL		
6	86376660	1	ELBOW, 1/4", 90		
7	86377180	2	WASHER, 1/2 X .75 DSP ZNPLT		
8	86376670	1	FITTING, ELBOW, 1/4", 90		
9	86376680	1	FITTING, GUEST, STRAIGHT		
10	86376690	2	FITTING, GUEST, 90		
11	86376700	1	HOSE, 1/4", BOTTLE CARTRIDGE		
12	86376710	1	HOSE, 3/8", BOTTLE CARTRIDGE		
13	86376720	1	HOSE, BOTTLE CARTRIDGE ASSY		
14	86377190	4	SCREW, 6-32 X 1.25 HEXFLGH ZNPLT		
15	86377200	4	WASHER, PUMP MOUNT		
16	86376730	4	GROMMET, DAMPNER, PUMP		
17	86377210	4	NUT, 6-32, HEX NYLOCK STL ZNPLT		
18	86376740	1	HOSE, 1/4", PUMP CAGE		

# Wiring Diagram

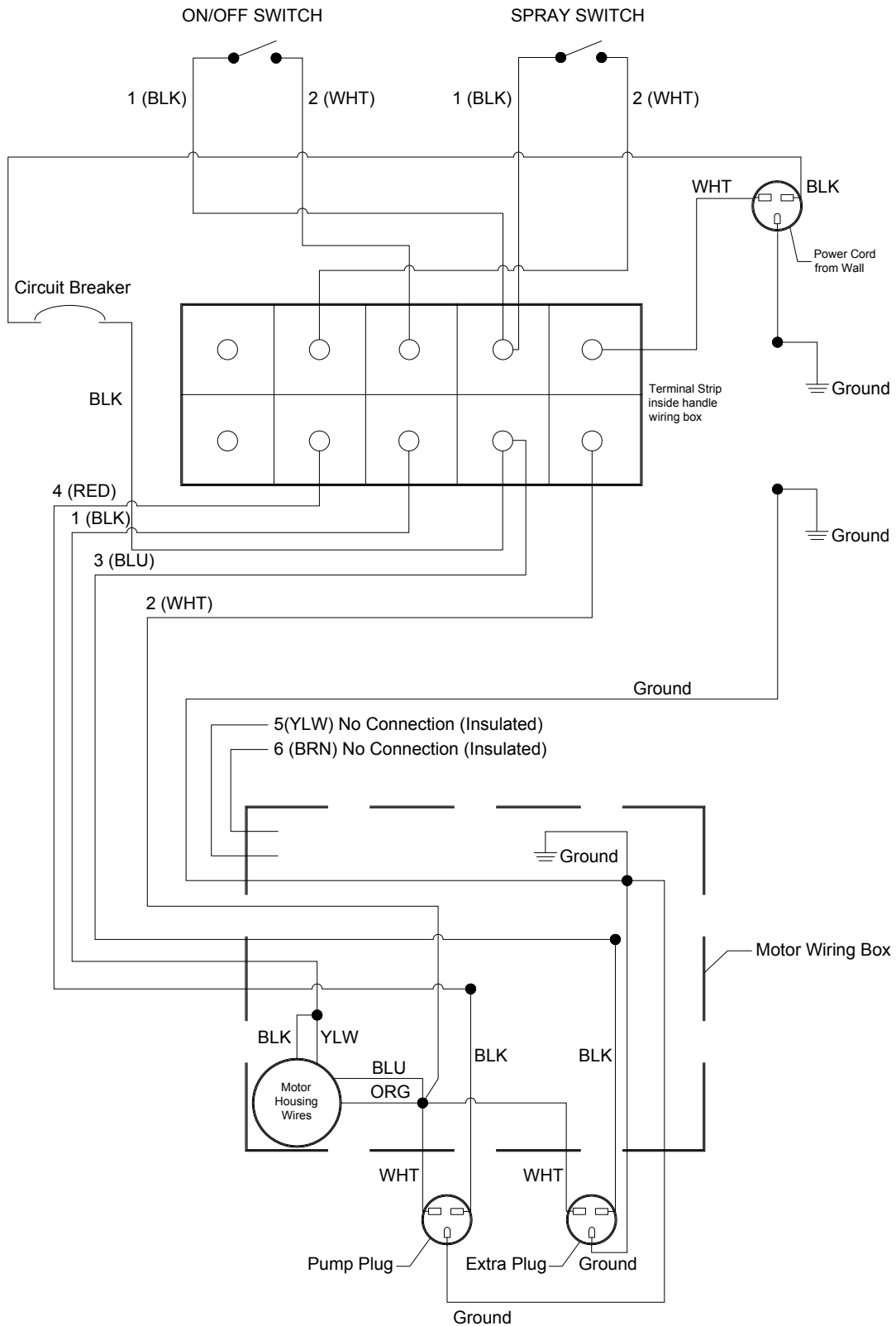

<b>PART NO.</b>	<b>DESCRIPTION</b>	<b>SERIAL NO. FROM</b>	<b>NOTES</b>
86374640	PAD, ABSORBENT, 21"		
86374690	REPLACEMENT DRIVER PLATE PACK		
86374660	PAD, CARPET, 19"		
86374700	ASSY, GLIDER SET		
86374710	ASSY, WEIGHT KIT		
86374680	BRUSH, SCRUB		
86374670	PAD, STRIPPING, CHEMICAL FREE, 18"		
86374720	BOTTLE CARTRIDGE, 2.5 GAL		

**Suggested Spare Parts**

<b>PART NO.</b>	<b>DESCRIPTION</b>	<b>SERIAL NO. FROM</b>	<b>NOTES</b>
86375100	STRAINER, CHECK VALVE		
86375110	ASSY, BEARING, 17 DISC		
86375120	SWITCH, DP, 2 POS, ROCKER		
86375130	SWITCH, DP, 2 POS, ROCKER SPR		
86375140	BREAKER, 20A 125/250VAC 32VDC		