

PRESTO!

MINI-EXTRACTOR

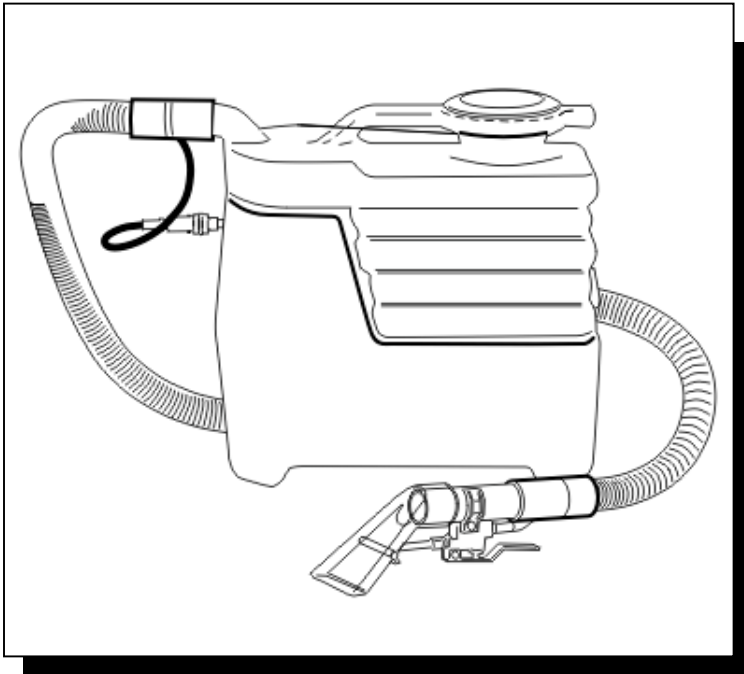

Operating Instructions (GB/USA)

MODEL: PRS2
PRSD2

QUEST® ... for Continuous Improvement.
Windsor's Quality Management System is Certified ISO 9001.



98901 08/19/04



CLICK TO ORDER PARTS

MACHINE DATA LOG/OVERVIEW

MODEL _____

DATE OF PURCHASE _____

SERIAL NUMBER _____

SALES REPRESENTATIVE # _____

DEALER NAME _____

OPERATIONS GUIDE NUMBER _____

PUBLISHED _____

Copyright 1995 Windsor Industries, Printed in USA

YOUR DEALER

Name: _____

Address: _____

Phone Number: _____

TABLE OF CONTENTS

Machine Data Log/Overview2
Table of Contents3

HOW TO USE THIS MANUAL

How to use this Manual..... 1-1

SAFETY

Important Safety Instructions.....2-1
Hazard Intensity Level2-2
Grounding Instructions.....2-3

OPERATIONS

Machine Operations.....3-1
 Set Up and Operation3-1
 Shut Down and Storage.....3-1

MAINTENANCE

Maintenance Schedule4-1
 Daily Maintenance4-1
 Periodic Maintenance4-1
Solution Pump Replacement4-1
Vacuum Motor Replacement.....4-1
 Carbon Brush Replacement4-1
Machine Troubleshooting.....4-2
Wiring Diagram4-2
Service Schedule4-3

GROUP PARTS LIST

Recovery Tank Group.....5-1
Solution Tank Group5-3
Labels and Parts List.....5-5
Presto Hand Tool and Parts List.....5-6
Presto Deluxe Hand Tool Group5-7
Presto Cart and Parts List5-8
Suggested Spare Parts.....5-9
Warranty 5-10

HOW TO USE THIS MANUAL

This manual contains the following sections:

- HOW TO USE THIS MANUAL
- SAFETY
- OPERATIONS
- MAINTENANCE
- PARTS LIST

The HOW TO USE THIS MANUAL section will tell you how to find important information for ordering correct repair parts.

Parts may be ordered from authorized Windsor dealers. When placing an order for parts, the machine model and machine serial number are important. Refer to the MACHINE DATA box which is filled out during the installation of your machine. The MACHINE DATA box is located on the inside of the front cover of this manual.

MODEL _____
DATE OF PURCHASE _____
SERIAL NUMBER _____
SALES REPRESENTATIVE # _____
DEALER NAME _____
OPERATIONS GUIDE NUMBER _____
PUBLISHED _____

Copyright 2001 Windsor Industries, Printed in USA

The model and serial number of your machine is on the back underside of machine.

The SAFETY section contains important information regarding hazard or unsafe practices of the machine. Levels of hazards is identified that could result in product or personal injury, or severe injury resulting in death.

The OPERATIONS section is to familiarize the operator with the operation and function of the machine.

The MAINTENANCE section contains preventive maintenance to keep the machine and its components in good working condition.

The PARTS LIST section contains assembled parts illustrations and corresponding parts list. The parts lists include a number of columns of information:

- **REF** – column refers to the reference number on the parts illustration.
- **PART NO.** – column lists the part number for the part.
- **QTY** – column lists the quantity of the part used in that area of the machine.
- **DESCRIPTION** – column is a brief description of the part.
- **SERIAL NO. FROM** – column indicates the first machine the part number is applicable to. When the machine design has changed, this column will indicate serial number of applicable machine. The main illustration shows the most current design of the machine. The boxed illustrations show older designs. If column has an asterisk (*), call manufacturer for serial number.
- **NOTES** – column for information not noted by the other columns.

NOTE: If a service or option kit is installed on your machine, be sure to keep the KIT INSTRUCTIONS which came with the kit. It contains replacement parts numbers needed for ordering future parts.

NOTE: The 98# on the lower left corner of the front cover is the part number for this manual.

IMPORTANT SAFETY INSTRUCTIONS

When using an electrical appliance, basic precaution must always be followed, including the following:

READ ALL INSTRUCTIONS BEFORE USING THIS MACHINE.



WARNING:

To reduce the risk of fire, electric shock, or injury:

Use only indoors. Do not use outdoors or expose to rain.

Use only as described in this manual. Use only manufacturer's recommended components and attachments.

If the machine is **not working properly**, has been dropped, damaged, left outdoors, or dropped into water, return it to an authorized service center.

Do not operate the machine with any openings blocked. Keep openings free of debris that may reduce airflow.

This machine **is not** suitable for picking up hazardous dust.

Machine can cause a fire when operating near flammable vapors or materials. Do not operate this machine near flammable fluids, dust or vapors.

This machine is suitable for commercial use, for example in hotels, schools, hospitals, factories, shops and offices for more than normal housekeeping purposes.

Maintenance and repairs **must be done** by qualified personnel.

During operation, attention shall be paid to other persons, especially children.

When leaving unattended, secure against unintentional movement.

The machine shall only be operated by instructed and authorized persons.

When leaving unattended, switch off or lock the main power switch to prevent unauthorized use.

Do not handle the plug or machine with wet hands.

Do not unplug machine by pulling on cord. To unplug, grasp the plug, not the cord.

Do not use with damaged cord or plug. Follow all instructions in this manual concerning grounding the machine.

Do not pull or carry by cord, use cord as a handle, close a door on cord, or pull cord around sharp edges or corners.

Do not pull/run machine over cord. **Keep** cord away from heated surfaces.

Connect to a **properly** grounded outlet. See Grounding Instructions.

SAVE THESE INSTRUCTIONS

HAZARD INTENSITY LEVEL

The following symbols are used throughout this guide as indicated in their descriptions:

HAZARD INTENSITY LEVEL

There are three levels of hazard intensity identified by signal words -**WARNING** and **CAUTION** and **FOR SAFETY**. The level of hazard intensity is determined by the following definitions:

! WARNING

WARNING - Hazards or unsafe practices which COULD result in severe personal injury or death.

! CAUTION

CAUTION - Hazards or unsafe practices which could result in minor personal injury or product or property damage.

FOR SAFETY: To identify actions which must be followed for safe operation of equipment.

Report machine damage or faulty operation immediately. Do not use the machine if it is not in proper operating condition. Following is information that signals some potentially dangerous conditions to the operator or the equipment. Read this information carefully. Know when these conditions can exist. Locate all safety devices on the machine. Please take the necessary steps to train the machine operating personnel.

FOR SAFETY:

DO NOT OPERATE MACHINE:

Unless Trained and Authorized.

Unless Operation Guide is Read and understood.

In Flammable or Explosive areas.

In areas with possible falling objects.

WHEN SERVICING MACHINE:

Avoid moving parts. Do not wear loose clothing; jackets, shirts, or sleeves when working on the machine. Use manufacturer approved replacement parts.

GROUNDING INSTRUCTIONS

THIS PRODUCT IS FOR COMMERCIAL USE ONLY.

ELECTRICAL:

In the USA this machine operates on a standard 15 amp 115V, 60 hz, A.C. power circuit. The amp, hertz, and voltage are listed on the data label found on each machine. Using voltages above or below those indicated on the data label will cause serious damage to the motors.

EXTENSION CORDS:

If an extension cord is used, the wire size must be at least one size larger than the power cord on the machine, and must be limited to 50 feet (15.5m) in length.

GROUNDING INSTRUCTIONS:

This appliance must be grounded. If it should malfunction or break down, grounding provides a path of least resistance for electric current to reduce the risk of electric shock. This appliance is equipped with a cord having an equipment-grounding conductor and grounding plug. The plug must be inserted into an appropriate outlet that is properly installed and grounded in accordance with all local codes and ordinances.

This appliance is for use on a nominal 120-volt circuit, and has a grounded plug that looks like the plug in "Fig. A". A temporary adaptor that looks like the adaptor in "Fig. C" may be used to connect this plug to a 2-pole receptacle as shown in "Fig. B", if a properly grounded outlet is not available. The temporary adaptor should be used only until a properly grounded outlet (Fig. A) can be installed by a qualified electrician. The green colored rigid ear, lug, or wire extending from the adaptor must be connected to a permanent ground such as a properly grounded outlet box cover. Whenever the adaptor is used, it must be held in place by a metal screw.

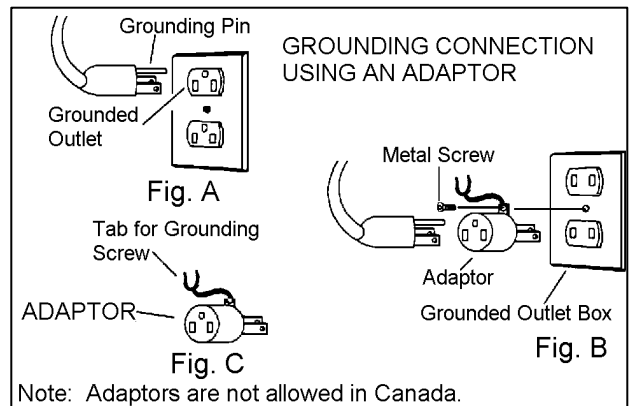

Improper connection of the equipment-grounding conductor can result in a risk of electric shock. Check with a qualified electrician or service person if you are in doubt as to whether the outlet is properly grounded. Do not modify the plug provided with the appliance - if it will not fit the outlet, have a proper outlet installed by a qualified electrician.

MACHINE OPERATIONS

SET UP AND OPERATION

1. Upon removing your new mini-extractor from the box, loosen the latch at back end of the machine that secures the recovery tank to the solution tank. Remove the recovery tank from the solution tank.
2. Pour clean, hot water to the indicated fill line of the solution tank. **To avoid possible tank distortion, water temperature must not exceed 140 F (60C).**
3. Add a non-foaming cleaning solution concentrate, for use in hot water extractors at the proportions noted on the container (See list below), into solution tank.
4. Place the recovery tank back onto the solution tank and refasten the latch.
5. Plug the power cord into grounded outlet (See GROUNDING INSTRUCTIONS).
6. Connect the vacuum and cleaning tool hoses to the extractor. This unit is equipped with an 1/8" male quick connect for solution hose attachment and a 1" ID vacuum hose hookup. Insure that the female solution hose coupler is securely locked onto the male coupler on the extractor.
7. Turn switch ON. This switch operates both the vacuum motor and the water pump. **NOTE: The pump is an oscillating pump and should not be run dry for extended periods of time. This may cause damage to your pump, therefor voiding your warranty.**
8. Squeeze the solution lever on the cleaning tool to spray cleaning solution and place the vacuum head on the surface to be cleaned. Normally, chemical is applied on the **push** stroke while vacuuming is done on the **pull** stroke. For heavily soiled carpets the hand tool may be used in the scrubbing manner, applying chemical in both the push and pull stroke.
ALWAYS FINISH UP AN AREA WITH A VACUUM PULL STROKE.
9. The shutoff float inside the recovery tank will impede the vacuum flow when the tank is full. When this occurs, empty the recovery tank.
NOTE: Dispose of waste in a proper manner which would not violate any Local, State or Federal law.

! CAUTION

Operating Vacuum after shutoff has activated could draw water directly into the vac motor. This will cause damage to the motor, therefor voiding your warranty.

! CAUTION

ALWAYS TEST UPHOLSTERY/CARPET FOR COLOR FASTNESS IN AN INCONSPICUOUS PLACE. Also, to avoid prolonged drying times, do not spray too much solution in any one area.

! WARNING

Always use defoamer if foaming occurs. Foam will suspend large particles which may damage vacuum as well as allow liquid into the vacuum motor without activating the float shutoff.

! WARNING

To prevent possible disease hazard, before attempting to clean bodily fluids spills, you must kill any viruses, germs or bacteria present in the bodily fluid.

SUITABLE CHEMICALS

Alkalis
Clorox II Bleach*
Defoaming Agents
Detergents
Hydroxides
Oxygen Bleaches
Soaps
Sta-Puf Fabric
Softener*
Vinegar

INCOMPATIBLE CHEMICALS

Aldehydes
Aromatic Hydrocarbons
Butyls
Carbon Tetrachloride
Clorox*
Chlorinated Bleaches
Chlorinated Hydrocarbons
D-Limonene
Lysol*
Methyls (MEK)
Perchloroethylene (perc)
Phenols
Trichlorethylene

*Registered Trademark

! WARNING

Before making any adjustments or performing any maintenance to your machine, disconnect the power cord from the electrical source.

SHUT DOWN AND STORAGE

1. Turn Switch OFF. Empty recovery tank completely and rinse several times to remove any dirt or debris that may be left behind.
2. Tip the solution tank over a sink to drain any unused cleaning solution and rinse with clean water to remove any suds left behind by the cleaning chemicals. **NOTE: Dispose of waste in a proper manner which would not violate any Local, State or Federal law**
3. Run a small amount of clean water through pump if chemicals were used. This will help insure the life of your pump.
4. Check the spray jet on the cleaning tool for full spray pattern and inspect vac head for any obstructions. Also make sure to clean the filter cap attached to portal cover of any debris that may have been trapped during cleaning.
5. Remove as much moisture from system before storing in cold climates. Excess water may freeze during storage and crack internal components, causing damage to the unit.

DAILY MAINTENANCE:

Follow same procedure for Shut Down and Storage.

PERIODIC MAINTENANCE:

1. Twice a month, flush a white vinegar solution (one quart vinegar to two gallons water) or anti-browning solution (mixed as directed) through the extractor. This will prevent build-up of alkaline residue in the system.
2. If spray jet becomes clogged, remove the spray tip, wash it thoroughly, and blow dry. **NOTE: DO NOT USE PINS, WIRE, ETC. TO CLEAN NOZZLE AS THIS COULD DESTROY THE SPRAY PATTERN.**
3. Apply silicone lubricant to solution nipple.
4. Periodically inspect all hoses, electrical cable and connections on your machine. Frayed or cracked hoses should be repaired or replaced to eliminate vacuum or solution pressure loss. If the cable insulation on the power cord is broken or frayed, repair or replace immediately. Don't take chances with electrical fire or shock.



WARNING: Only qualified maintenance personnel are to perform the following repairs.

SOLUTION PUMP REPLACEMENT:

1. Turn off all switches and unplug the machine.
2. Unfasten screws holding pump plate to bottom of solution tank.
3. Remove solution hoses from fittings on pump.
4. Remove pump from brackets and remove fittings and grounding wire.
5. Reverse process to install new replacement pump.

VACUUM MOTOR REPLACEMENT:

1. Turn off all switches and unplug machine.
2. Unfasten latch at back end of machine and remove recovery tank.
3. Unfasten screws holding switch plate to solution tank. Remove from solution tank. Locate the vacuum motor wires and disconnect at the connector.
4. Unfasten screws holding vac plate to switch plate. Remove the vacuum motor.

5. Reverse process to install vacuum motor replacement.

Vac Motor Carbon Brushes Replacement

Carbon Brushes 115V

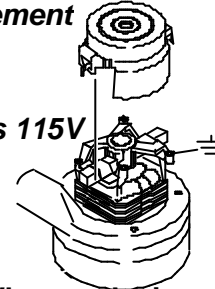

WARNING: The green ground wire must be attached for safe operation. See wiring diagram.

Note: When replacing carbon vac motor brushes loosen wire terminal BEFORE removing screws on bracket.

If armature commutator is not concentric, extremely pitted, or grooved the motor will need to be replaced or sent to a qualified service center to restore vac performance.

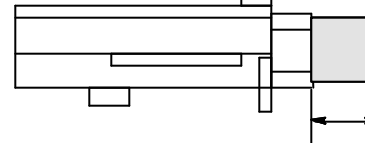
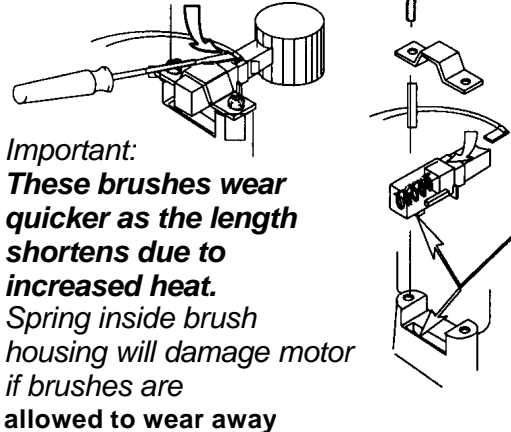

Periodically check the length of the carbon brushes. Replace both carbon brushes when either is less than 3/8" long.

TROUBLESHOOTING/WIRING DIAGRAM

TROUBLESHOOTING

PROBLEM.	CAUSE	SOLUTION
Little or no solution flow	Clogged spray jet on cleaning tool	Remove and clean jets
	Faulty pump	Check and replace pump. (Call Windsor Tech. Services first)
Loss of vacuum/ Solution recovery	Incorrectly attached solution hose	Ensure solution hose coupler is securely attached to the coupler on the solution tank.
	Incorrectly attached vac hose	Ensure vac hose is pushed completely onto the recovery tank inlet.
	Obstruction in cleaning tool	Inspect for and remove any debris.
	Recovery tank is not securely mounted on the solution tank.	Tighten latch on back end of the machine.

WIRING DIAGRAM

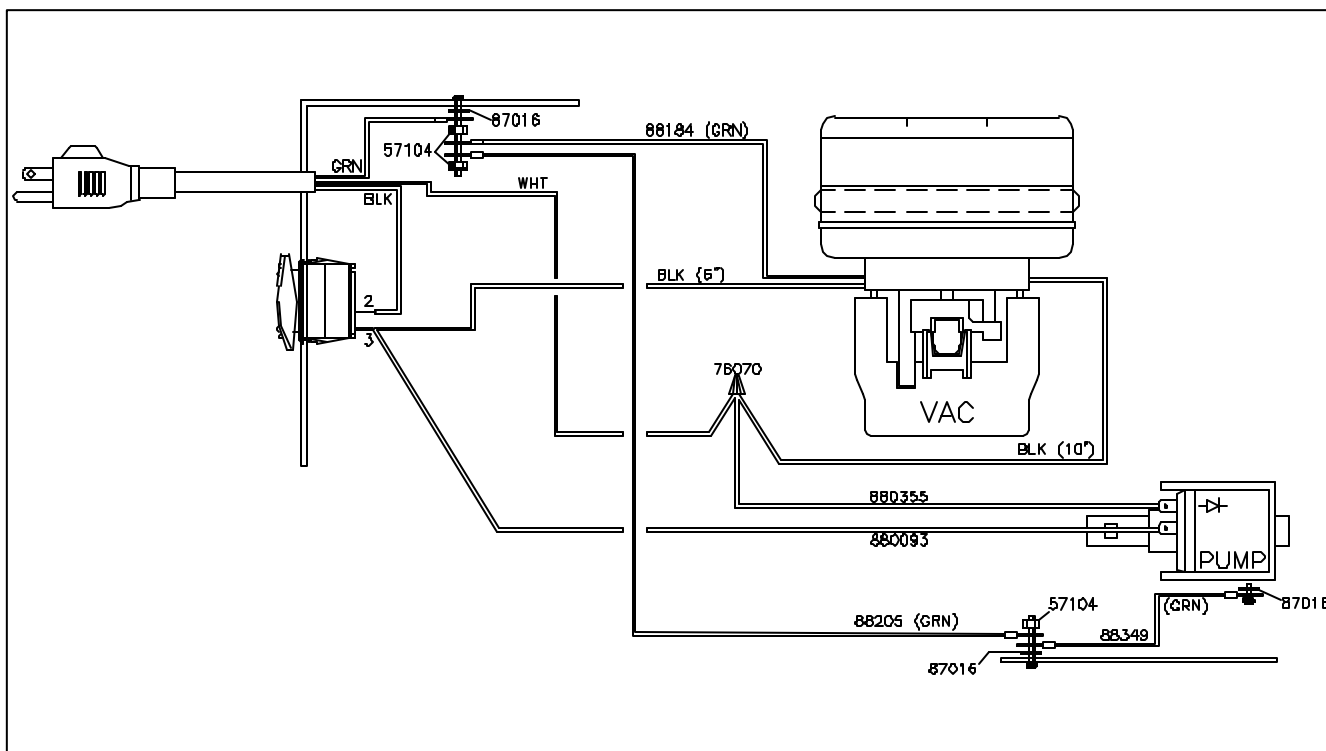

SERVICE SCHEDULE

MAINTENANCE	DAILY	WEEKLY	QUARTERLY
Check machine for cord damage	*		
Check hoses for wear, blockages, or damage	*		
Check handles, switches, and knobs for damage	*		
Check vac motor intake filter and clean	*		
Run one gallon of water through system	*		
Clean out recovery tank and check float valve to make sure it moves freely	*		
Clean out solution tank and remove and clean vacuum intake screen	*		
Clean outside of all tanks and check for damage	*		
Run vac motor for at least one minute to allow motor to dry	*		
Check all gaskets for wear and leakage		*	
Check vacuum intake screen for damage; replace if necessary		*	
Check pump pressure; observe spray pattern and check with gauge if necessary		*	
Check and clean solution screen		*	
Check cables for fraying		*	
Check overall performance of machine		*	
Check vac motor carbon brushes			*

RECOVERY TANK PARTS

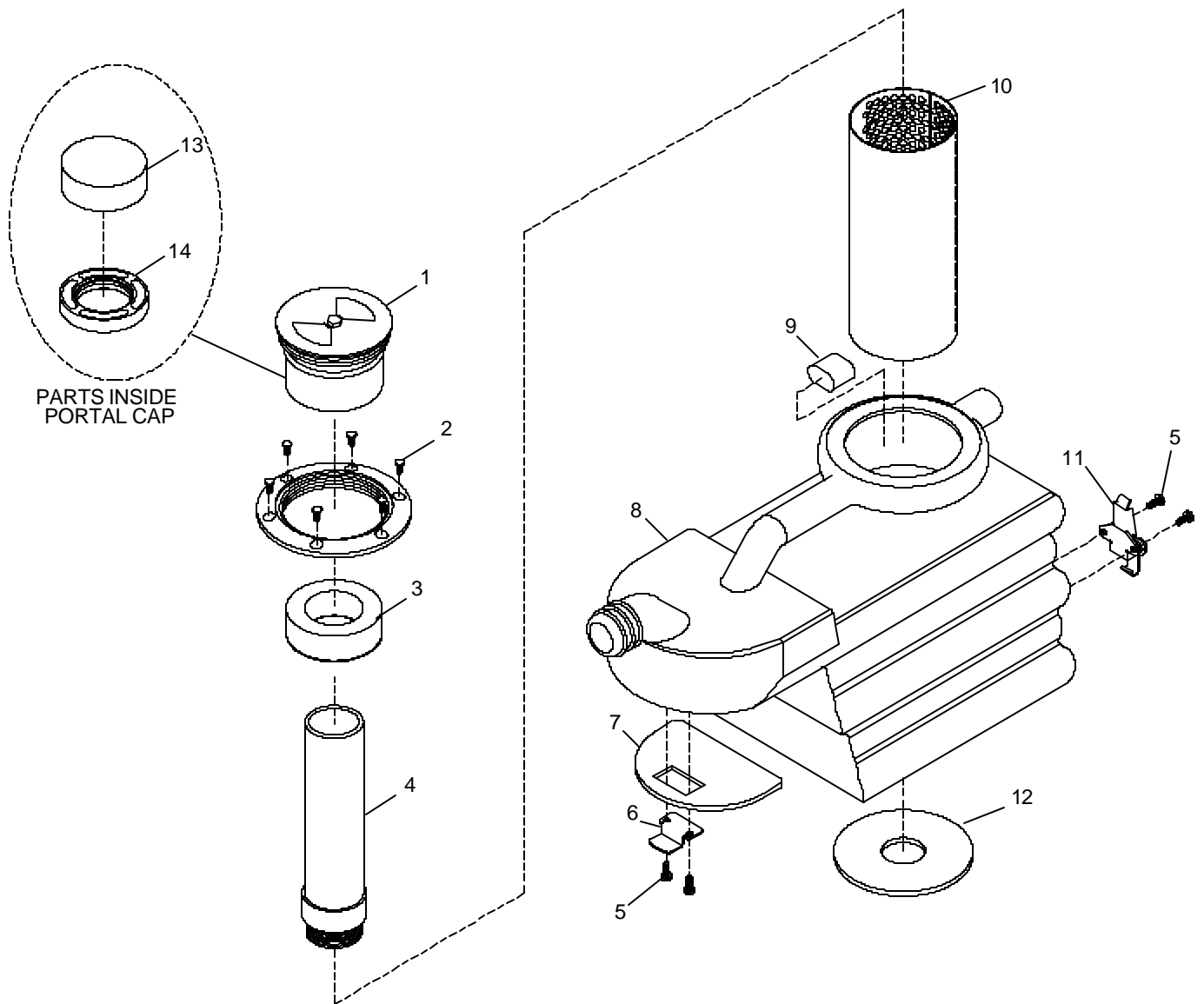

RECOVERY TANK PARTS LIST

REF	PART NO.	QTY	DESCRIPTION	SERIAL NO. FROM	NOTES:
1	05160	1	ASM, ACCESS COVER		
2	70546	6	SCR, 8 X ¾ PFHT/S BLK ZINC		
3	34391	1	FLOAT ASM SPOTTER WGHT		
4	78484	1	TUBE ASM, SPOTTER		
5	70683	4	SCR, 10-32 X 3/8 PPHMS SS NP		
6	50-501913	1	BRKT, REC/SOL TANK GRIP		
7	43-807525	1	GASKET, RECOVERY TANK SEAL		
8	75368	1	TANK, RECOVERY SPOTTER DRK BLU		
9	43-807578	1	PLUG, HANDLE RECOVERY TANK		
10	50-502114	1	PLATE, BACKSPLASH SHIELD		
11	46-802541	1	LATCH, TENSION 3.22L		
12	35168	1	GASKET, 2.5"ID X 4"OD X 3/8"T		
13	14-806573	REF	FOAM, AIR FILTER SPOTTER		
14	11-800518	REF	BUSHING, 3" PVC FLT SHUTOFF		

SOLUTION TANK PARTS

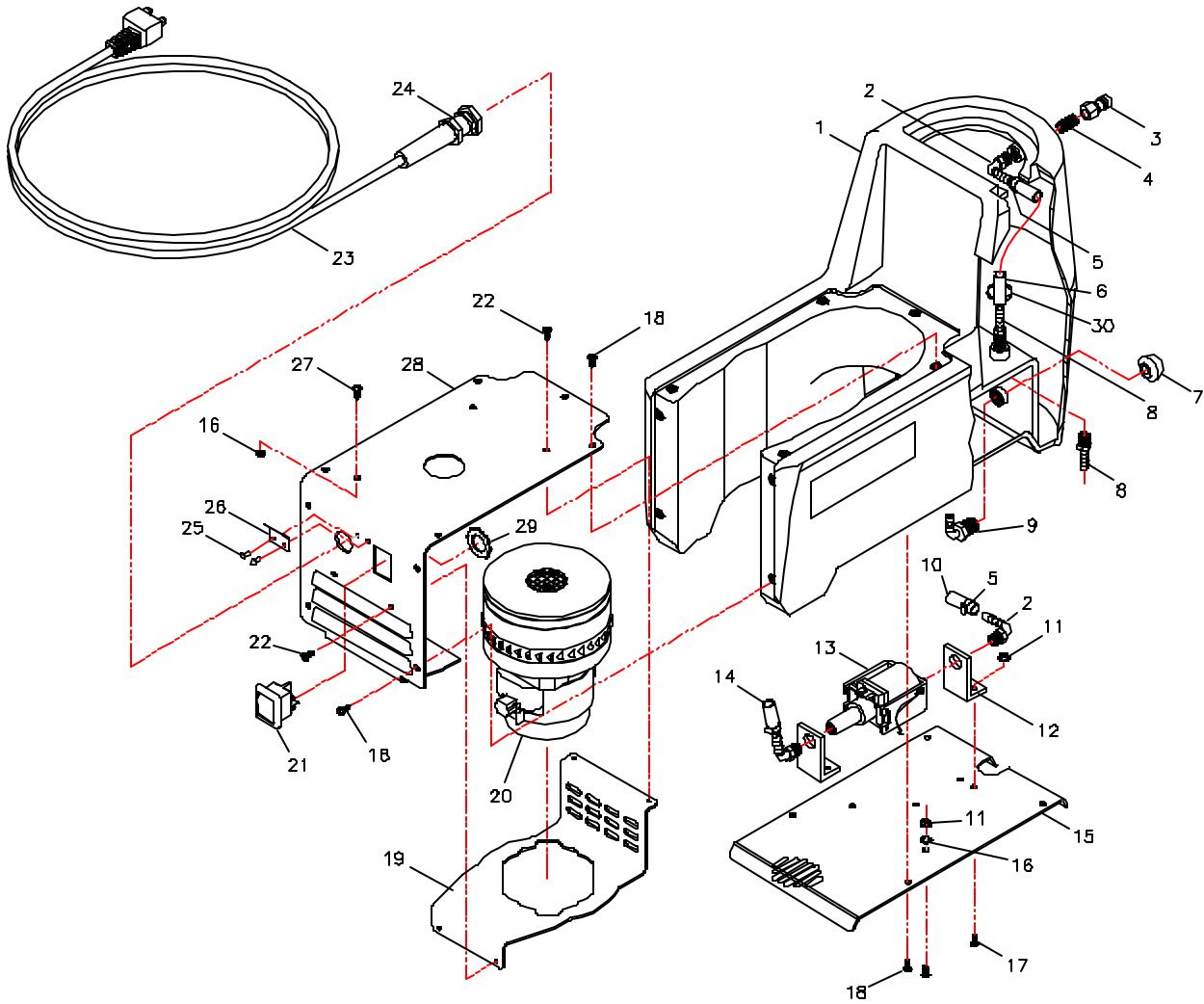

SOLUTION TANK PARTS LIST

REF	PART NO.	QTY	DESCRIPTION	SERIAL NO. FROM	NOTES:
1	75367	1	TANK, SPOTTER SOL DK GRY		
2	40066	3	HOSEBARB, 1/8NPT X 3/8 90D PLASTIC		
3	270-11A	1	NIPPLE, 1/8 FPT QD MALE BRASS		
4	56032	1	NIPPLE, 1/8 CLOSE		
5	20042	5	CLAMP, 3/8 HOSE (D-SLOT)		
6	39035	1	HOSE, 3/8" NYLOBRAID X 10"		
7	73864	1	STRAINER, 3/8 NPT 60 MESH		
8	40067	2	HOSEBARB, 1/8MPT X 3/8 PLASTIC		
9	40043	1	HOSEBARB, 3/8MPT X 3/8 90D		
10	39233	1	HOSE, 3/8" RUBBER X 17"		
11	57104	5	NUT, 10-32 W/STAR WASHER PLTD		
12	140446	2	BRKT, PVC FLOJET PUMP L-SHAPE		
13	250-78	1	PUMP, 110/120 60HZ FLOJET		
14	39049	1	HOSE, 3/8" RUBBER X 11"		
15	50-502111	1	PLATE, LOWER PANEL COVER		
16	87016	1	WASHER, #10 LOCK EXT STAR		
17	70088	5	SCR, 10-32 X 1/2 PPHMS SS NP		
18	70683	13	SCR, 10-32 X 3/8 PPHMS SS NP		
19	50-502108	1	PLATE, VAC MOTOR		
20	53800	1	VAC ASM, 115V SPOTTER		
21	72130	1	SWITCH, SPST 2 POSITION ROCKER		
22	70351	4	SCR, 10-32 X 3/8 HHTR W/STAR		
23	23181	1	CORD, 25' 18/3		
24	73505	1	STRAIN RELIEF, 1/2 NPT TRUMPET		
25	67023	2	RIVET, 1/8OD X 3/8 GRIP		
26	46-802542	1	KEEPER, TENSION LATCH		
27	70595	1	SCR, 10-32 X 1 PPHMS GRN		
28	50-502110	1	PLATE, SWITCH/CORD SPOTTER		
29	57040	1	NUT, 1/2 CONDUIT		
30	20103	1	CLAMP, 43/64" NYLON RATCHET	*	

LABELS & PARTS LIST

REF	PART NO.	QTY	DESCRIPTION	SERIAL NO. FROM	NOTES:
1	500009	1	LABEL, WARNING		
2	500528	2	LABEL, WINDSOR MAIN		
3	500529	2	LABEL, WINDSOR LOGO 6 X 1.75		
4	50776	1	LABEL, FOR SAFETY		
5	500480	1	LABEL, ON/OFF VAC/PUMP		

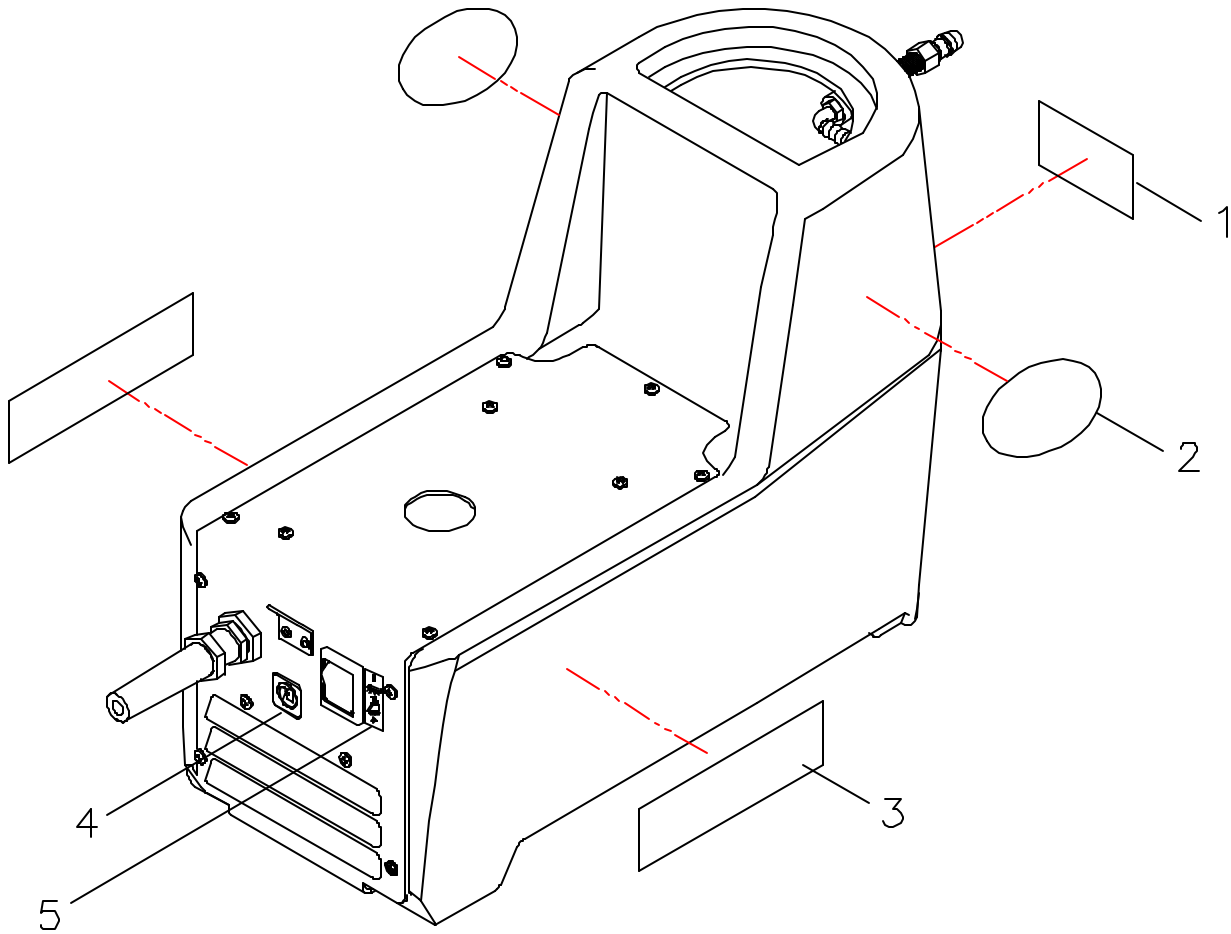

PRESTO HAND TOOL & PARTS LIST

REF	PART NO.	DESCRIPTION	SERIAL NO. FROM	NOTES:
1	41422	HOUSING, HANDTOOL SPOTTER		
2	20053	CLAMP, DHT VALVE		
3	39593	HOSE ASM, HOSE/CUFF CONNECTOR		
4	270-11	NIPPLE, 1/8 FPT QD FEM BRASS		
5	44074	JET, ASM W/O RING		
6	70268	SCR, 8-32 X1/4 PHST PLTD		
7	62918	PLATE, RETAINER W/SCRS		
8	54181	MANIFOLD, SPOTTER 3/16		
9	34384	FITTING, 1/8MPT X 3/16 COMP		
10	84177	VALVE ASM, SPOTTER PLASTIC		
	SHT	SPOTTER HAND TOOL		Entire assembly as Kit

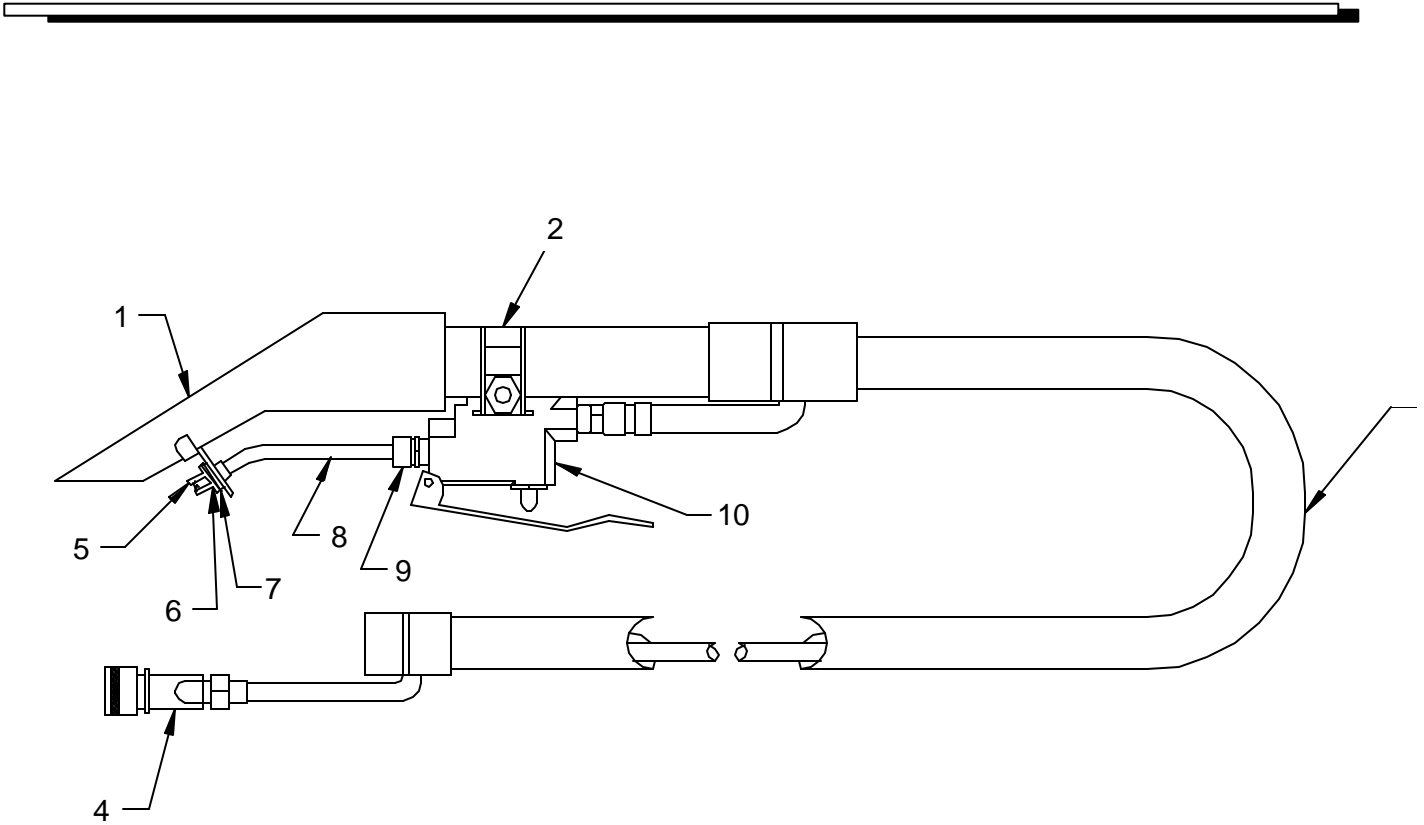

PRESTO DELUXE HAND TOOL ASSEMBLY

REF	PART NO.	DESCRIPTION	SERIAL NO. FROM	NOTES:
1	04007	ADAPTOR, 1/8 MPT X 1/8 FPT BR		
2	12509	BRUSH, DDH		
3	22026	COUPLER, 1.5 VAC HOSE		
4	27677	CUFF, SWIVEL DDH HOSE EXIT		
5	27678	CUFF, SWIVEL DDH		
6	27685	CONNECTOR, 1/4T COMP X 1/8 MPT		
7	31067	ELBOW, 45° 1/4T X 1/8 NPT		
8	39463	HOSE, VAC 1 1/2 X 5' DDH		
9	78384	HOUSING, DOUBLE VAC, ASM		
10	44052	JET, BODY MINI-QUICK W/ SEAL		
11	44060	JET, 8002 MINI-QUICK REPLACEMENT		
12	51248	LEVER, TRIGGER		
13	51249	LOCK, LEVER		
14	51250	LEVER, HANDLE		
15	270-11	NIPPLE, 1/8 FPT QD FEM BRASS		
16	57240	INSERT, 8-32 NUT		
17	66031	PIN, ROLL 1/8" X 3/4"L SS		
18	70045	SCREW, 8-32 X 1 PPHMS SS		
19	70704	SCREW, 6-32 X 7/8 PPHMS SS		
20	73776	SPRING, COMP. .08D X .75L X .01W		
21	73835R	SHIELD, DDH UPHOLSTERY		
22	78335	TUBE, 1/4OD X 77.5"		
23	84137	VALVE, 1/8 NPT		
24	87017	WASHER, #8 FLAT		
25	57049	NUT, 6-32 HEX NYLOCK SS		

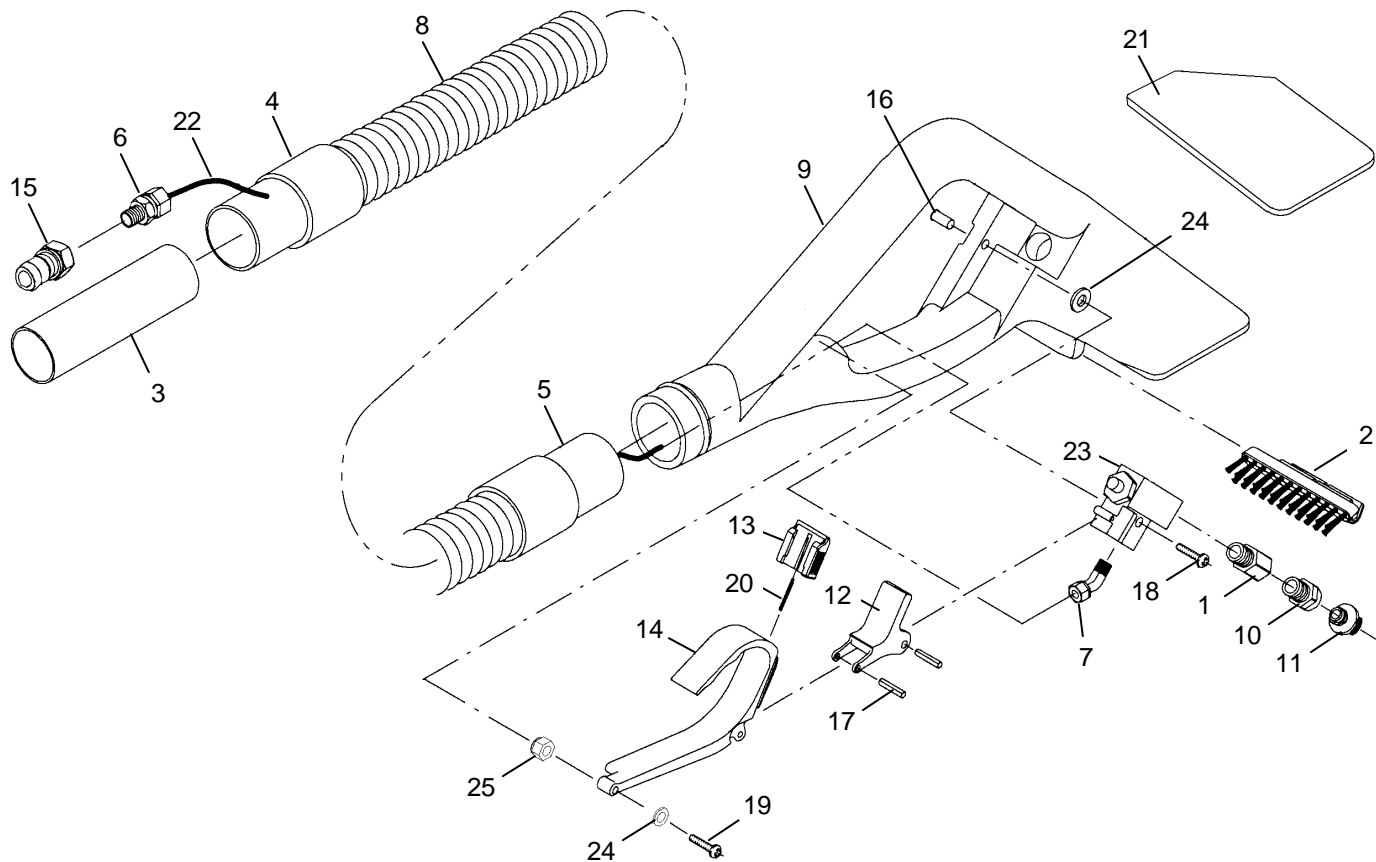

PRESTO CART & PARTS LIST

REF	PART NO.	DESCRIPTION	SERIAL NO. FROM	NOTES:
1	78310	TUBE, CART HANDLE		
2	70010	SCREW, 1/4-20 X 1.5 TAP PLTD.		
3	57196	NUT, 1/2 STAR LOCK PUSH-ON		
4	57104	NUT, 10-32 HEX W/ STAR WASHER		
5	89048	WHEEL		
6	57047	NUT, 1/4-20 LOCK		
7	27637	BASE, CART PRESTO		
8	70088	SCREW, 10-32 X 1/2 PHMS		
9	140088	BASKET, 3 BOTTLE		
10	18010	CASTER, SWIVEL		

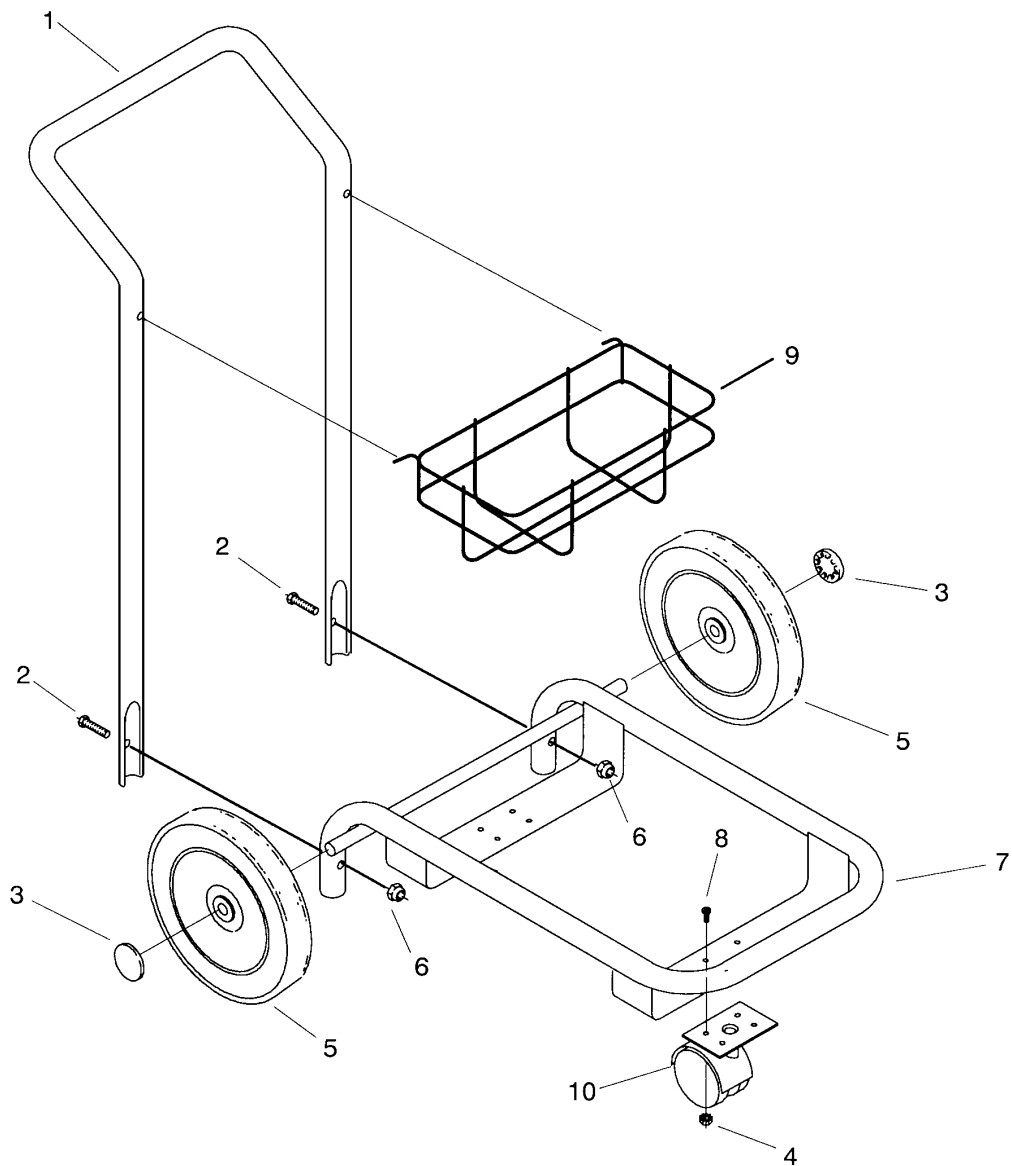

SUGGESTED SPARE PARTS

PART NO.	DESCRIPTION	SERIAL NO. FROM	NOTES:
44074	JET ASM W/O-RING		
44060	JET, 8002 MINI-QUICK REPLACEMENT		
72130	SWITCH, SPST 2 POSITION ROCKER		
53800	VAC ASM, 115V SPOTTER		
250-78	PUMP, 110/120 60HZ FLOJET		