

COMMODORE 115V-98048

**MONSTER JANITORIAL** [CLICK TO ORDER PARTS](#)

# COMMODORE



## INSTRUCTION MANUAL

■ OPERATION

■ CARE

■ SERVICE



Model CMD



WINDSOR INDUSTRIES, INC., 1351 W. Stanford Ave., Englewood, CO 80110 USA • 303/762-1800 • FAX 303/762-0817

---

## IMPORTANT SAFETY INSTRUCTIONS

---

When using an electrical appliance, basic precautions should always be followed, including the following:



**Read all instructions before using this machine. This machine is for commercial use.**

**WARNING: TO REDUCE THE RISK OF FIRE, ELECTRICAL SHOCK, OR INJURY:**

1. Do not use outdoors or expose to rain.
2. Machines can cause a fire when operated near flammable vapors or materials. Do not operate this machine near flammable fluids, dust, vapors or gas. Do not pick up burning materials such as cigarettes or matches.
3. Do not leave the machine unattended. Unplug machine from power outlet when not in use.
4. Switch off switches before disconnecting power cord from electrical outlet.
5. Maintenance and repairs must be done by qualified personnel.
6. Do not disconnect cord from outlet by pulling on cord. Grasp plug to remove from outlet.
7. Do not use power cord as a handle, close door on cord, or pull cord around sharp edges or corners.
8. Do not operate machine with any openings blocked. Keep openings free of debris that may reduce air flow.
9. Do not use machine as a step or operate machine unless it is completely assembled.

---

## SAVE THESE INSTRUCTIONS

---

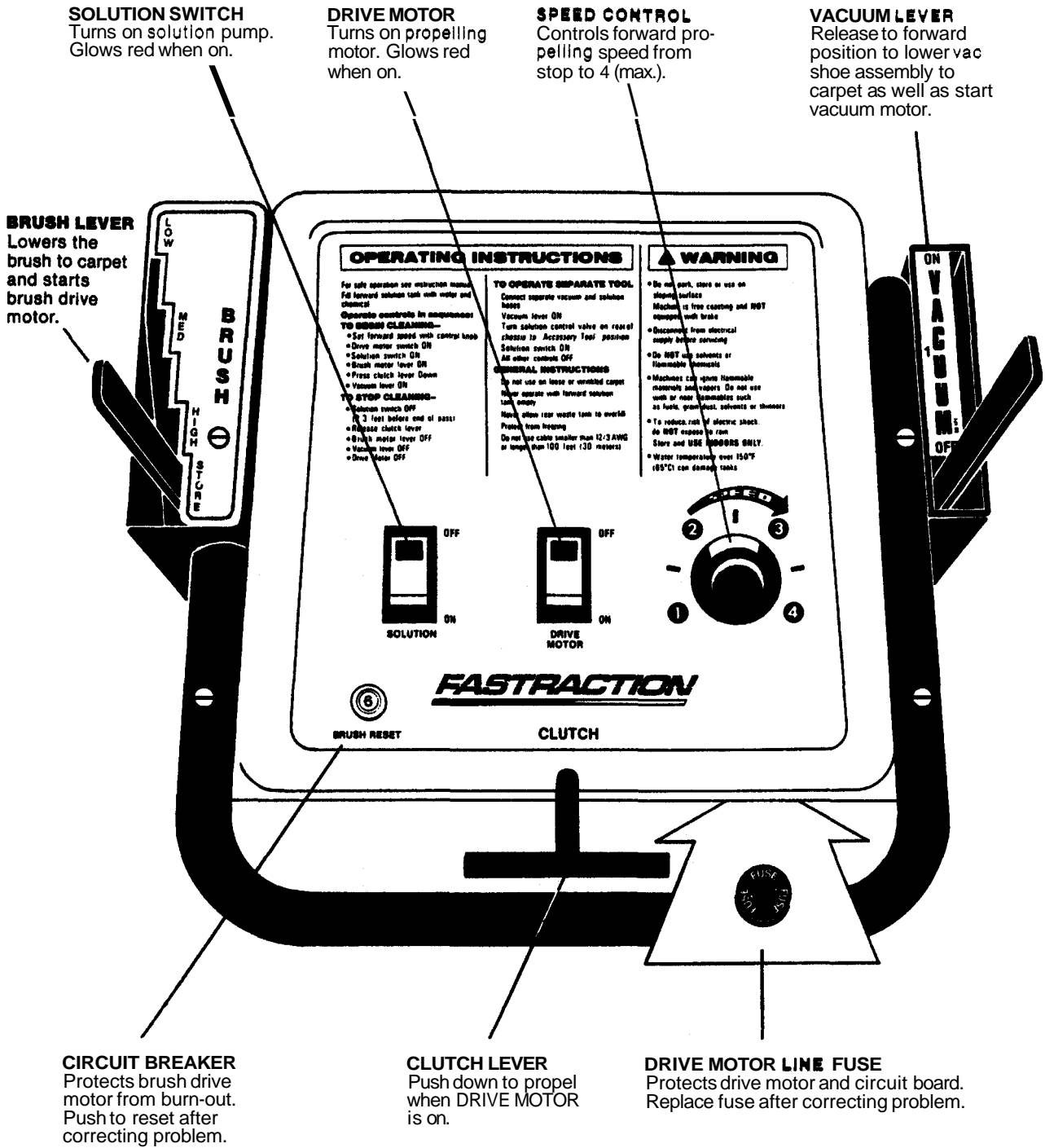

# COMMODORE 115V

## PREPARING THE COMMODORE

**FILL SOLUTION TANK** to the desired level according to the marked gauge inside the tank. **CAUTION:** If a bucket is used to fill the tank, be sure that it is clean.

**CAUTION:** To avoid possible distortion of polyethylene solution/recovery tanks, **DO NOT USE WATER TEMPERATURE THAT EXCEEDS 150°F (65°C).**

**LIQUID DETERGENTS ARE PREFERRED,** however if a powdered detergent is used, be sure it is fully dissolved **BEFORE** putting it in the solution tank. Do this by dissolving it in a bucket containing about 1 gallon of hot water before emptying it into the solution tank.

You will find a 1 cup (8 oz.) measure on the bottom of the solution tank lid to assist you in making the proper dilution of cleaning chemical and water.

**WARNING:** Do not put defoamer, solvents, spotter or prespray chemicals in the solution tank.

## CHEMICALS

The internal parts of the pump used in the extractor is suitable for use with most carpet cleaning chemicals. But it is susceptible to chemical attack from some cleaning substances, such as hydrocarbon solvents and chlorinated bleaches. These noncompatible materials are not of the type normally used for carpet cleaning,

### SUITABLE CHEMICALS

Alkalis  
Clornx II Bleach<sup>1</sup>  
Defoaming Agents  
Detergents  
Hydroxides  
Oxygen Bleaches  
soaps  
Sta-Puf Fabric Softener<sup>1</sup>  
Vinegar  
White Monday Bleach<sup>1</sup>  
<sup>1</sup>Registered Trademark

### NONCOMPATIBLE CHEMICALS

Aldehydes  
Aromatic Hydrocarbons  
Butyls  
Carbon Tetrachloride  
Clorox<sup>®</sup>  
Chlorinated Bleaches  
Chlorinated Hydrocarbons  
Lysol<sup>®</sup>  
Methyls (MEK)  
Phenols  
Trichlorethylene

**PLACE RECOVERY DOME** atop recovery tank, being sure that gasket material is undamaged and making a good seal with the recovery tank. Connect hose from vac shoe to dome.

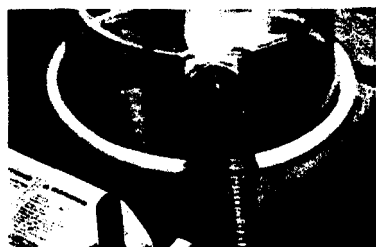

1.

**ATTACH ELECTRIC CABLE** to Twist-Lok connection at rear of control panel beneath operating handle.

- Note that all switches are in "off" position when attaching Twist-Lok.

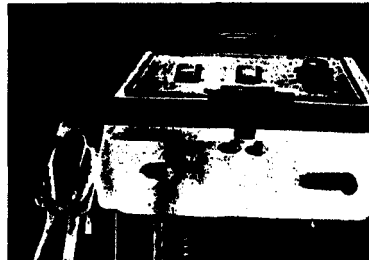

- 2. ■ Attach cable strain reliever as shown to prevent damage to power cord connections.

## GROUNDING INSTRUCTIONS

This appliance must be grounded. If it should malfunction or breakdown, grounding provides a path of least resistance for electric current to reduce the risk of electric shock. This appliance is equipped with a cord having an equipment-grounding conductor and grounding plug. The plug must be plugged into an appropriate outlet that is properly installed and grounded in accordance with all local codes and ordinances.

**WARNING:** Improper connection of the equipment-grounding conductor can result in a risk of electrical shock. Check with a qualified electrician or service person if you are in doubt as to whether the outlet is properly grounded. Do not modify the plug provided with the appliance — if it will not fit the outlet, have a proper outlet installed by a qualified electrician.

This machine is for use on a nominal 120-volt circuit, and has a grounded plug that looks like the plug illustrated in Fig. A. A temporary adapter that looks like the adapter illustrated in Figs. B and C may be used to connect this plug to a 2-pole receptacle as shown in Fig. B if a properly grounded outlet is not available. The temporary adapter would be used only until a properly grounded outlet (Fig. A) can be installed by a qualified electrician. The green colored rigid ear, lug, or the like extending from the adapter must be connected to a permanent ground such as a properly grounded outlet box cover. Whenever the adapter is used, it must be held in place by a metal screw.

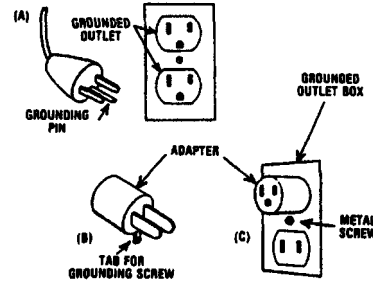

## TO BEGIN CLEANING:

FOLLOW THE SEQUENCE BELOW. . .

1. Set forward speed with control knob.
2. Press "drive" motor switch to "on" position. Red light will glow.
3. Press "solution" switch to "on" position. Red light will glow.
4. Release "Brush Motor Lever" to "on" position and adjust brush to correct cleaning height. The brush setting is correct when the bristles **sweep** the surface of the carpet.



**NOTE:** Starting the machine with dry brush resting on the carpet may trip circuit breaker.

5. Press down on clutch lever to start forward movement.
- WARNING:** Do not secure clutch lever in "down" position. Damage to machine could occur.
6. Release vacuum lever to "on" position to start vac motor and lower vac shoe to carpet.

## TO STOP CLEANING

FOLLOW THE SEQUENCE BELOW . . .

1. Push solution switch to "off" (2 or 3 feet before end of pass.)
2. Release clutch lever.
3. Lift brush lever to "off" position.
4. Lift vacuum lever to "off" position.
5. Push drive motor switch to "off" position.

**WARNING:** The drive train of the COMMODORE is **FREE WHEELING** and the machine should not be left unattended or used on sloping surfaces or ramps.

**TO PULL THE COMMODORE IN REVERSE,** or go forward without power... first raise vacuum and brush levers to "off" position.

# COMMODORE 115V

## CLEANING TIPS . . .

- **GO SLOW** on very dirty carpet to avoid streaking. Be prepared to make two cleanings if carpet is badly soiled. Prespraying may also be necessary.
- Narrow bands of streaking can result from a plugged nozzle. See service section for Instructions. Pay more attention to using a clean bucket when filling solution tank to avoid future problems.
- Paths, or wide stripes, over the carpet can occur with certain types of carpets. This is due to the "lay" of the carpet fibers. It will go away when vacuumed.
- Be sure to overlap enough to prevent uncleaned stripe.

**WORK AWAY** from the power source if possible. Begin cleaning next to wall. This will allow you to always make turns away from the cable.

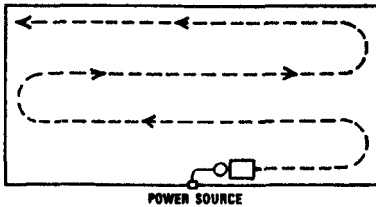

**KEEP THE MACHINE MOVING** when jets are "on." If it becomes necessary to stop to maneuver in a turn or corner, push the solution switch to the "off" position. **CAUTION:** Overwetting of the carpet is likely, or damage to the carpet is possible, if the COMMODORE is permitted to stand in one position with the jets or brush on.

**THE FORWARD SPEED** of the COMMODORE is controlled with the knob on the control panel, numbered from 1 to 4.

**RESTORATION OR SALVAGE CLEANING** will be best accomplished with the control set from 1½ to 2½.

**MAINTENANCE CLEANING** can be best accomplished somewhere from 2½ up to 4, depending upon the condition of the carpet being cleaned.

Forward speeds and approximate coverages are:

| SETTING | SPEED FPM | COVERAGE SQUARE FEET PER HOUR (Straight ahead cleaning — no allowances) |
|---------|-----------|---|
| 4       | 60        | 5775  |
| 3½      | 43        | 4139  |
| 3       | 32        | 3080  |
| 2½      | 25        | 2406  |
| 2       | 17        | 1636  |

## SPRAY JETS

To prevent clogged jets due to alkaline build-up, the spray system should be flushed with 2 or 3 gallons of clean hot water at the end of each day. The COMMODORE is equipped with "quick change" jets that can be easily removed for cleaning. To remove — push jet in and rotate ¼ turn. Wash jets and blow dry. Do not use pins or wire to remove obstruction as this will change spray pattern.

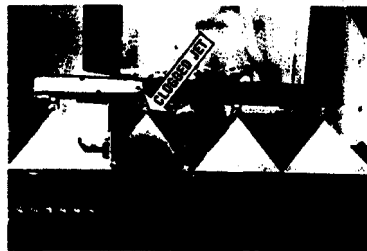

**TO USE FLOOR AND HAND TOOLS** with the COMMODORE:

1. Attach auxiliary solution hose to outlet nipple.
2. Connect vac hose to recovery dome.
3. Turn solution control valve to "accessory tool" position.
4. Press pump switch "on."
5. Lower vac lever to "on" position to start vac motor.

**WARNING:** All other switches on control panel must remain "OFF."

6. Make sure solution control valve is returned to "carpet spray" position before using the COMMODORE for self-contained carpet cleaning.



5.

## CLEANUP AND STORAGE

**EMPTY RECOVERY TANK** directly into floor drain. Flush inside of recovery tank with clean water. Clean the inside of the recovery dome.



6.

**EMPTY SOLUTION TANK** by detaching recovery hose at vac shoe and placing into solution tank with vacuum motor running.

**CAUTION:** Never allow recovered solution to remain in tank when **not** in use; nor allow unused solution to remain in solution tank when in storage.

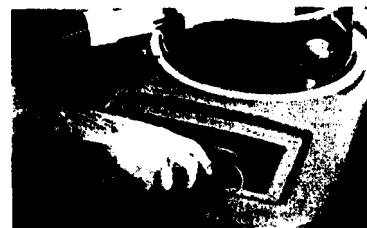

7.

## COMMODORE 115V

**STORE COMMODORE** with recovery shoe in the "up" position. Place recovery dome upside down in recovery tank as shown to permit drying of gasket and the inside of the tank.



8.

**INSPECT** screens in solution and recovery tank. Remove and rinse with hot water.

### PERIODIC MAINTENANCE

**EVERY TWO WEEKS:**

**CLEAN SOLUTION SYSTEM** by diluting 2 gallons of clean water with a quart of white vinegar (acetic acid) in solution tank. Run solution through the system with the machine parked over a floor drain. This procedure will free the system of harmful buildups which could eventually cause it to plug.

**EVERY 500 OPERATING HOURS:**



9.

**OIL FRONT DRIVE WHEEL BEARINGS** by removing hub cap and snap ring on axle. Slide wheel off axle and apply 6 drops of 10W oil to bearings.

**TO EXPOSE WORKING PARTS FOR INSPECTION** loosen screws holding tank support bracket to frame and tilt tank assembly forward.

**WARNING:** Remove machine power cord from electrical source before making any adjustments or repairs to the machine.



10.

**THE HOUR METER** keeps track of operating hours. It is wired into the vac motor circuit so that all operations using the vacuum are recorded.

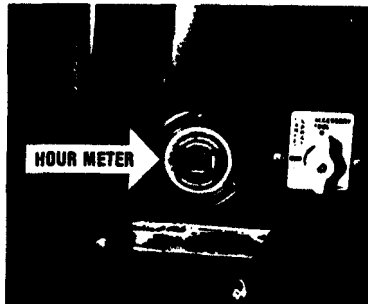

11.

**REMOVE VACUUM MOTOR** to inspect carbon brushes for wear. If worn to 3/8 inch, the brushes should be replaced. See service section for instructions.

**USE COMPRESSED AIR** to blow out dust in brush drive motor.

### SERVICING THE COMMODORE

**WARNING:** Remove machine power cord from electrical source before making any adjustments or repairs to the machine. **Only qualified maintenance personnel are to perform repairs.**

**CAUTION:** When replacing electrical parts refer to machine Wiring Diagram for proper connections.

#### TANK REMOVAL

1. Empty solution and waste water tanks.

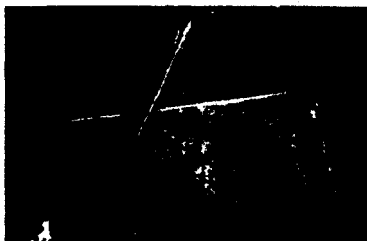

12.

2. Loosen screws holding tank support bracket to frame (see Photo 10) and tip tank assembly forward.
3. Disconnect hoses from tank and vac motor.



13.

4. Remove front hinge pins and set tank aside.



14.

#### TANK REPAIR:

The tanks are made of Polyethylene. Small holes, cracks, etc., can be repaired by using heat. Apply low heat from torch to damaged area until material is softened. Use screw driver blade or other flat metal tool to seal damaged area.

#### VACUUM MOTOR REMOVAL

1. Disconnect hose from vac motor exhaust.



15.

2. Disconnect vac motor leads from terminal block.
3. Remove 3 screws holding vac motor and remove vac motor.

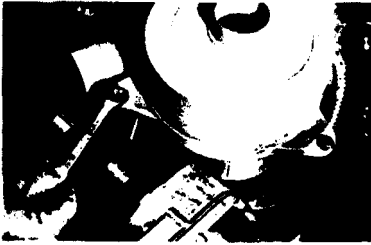

16.

4. To inspect motor brushes, remove metal band around motor and remove brush holder assembly. Brushes should be replaced when worn to 3/8 inch or after about 750 operating hours. After second brush replacement, armature commutator should be checked for pitting and concentricity. Vacuum motors can be repaired but such repairs should be made by a qualified motor repair shop.

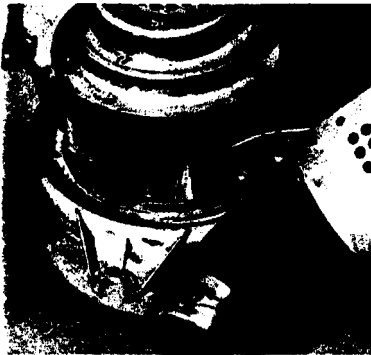

17.

**SOLUTION PUMP REMOVAL**

1. Disconnect solution lines at pump.
2. Remove (4) screws holding pump to base.
3. Lift pump up to access solution inlet line and disconnect from pump head. Refer to Pump Drawing for Replacement Pump Parts.

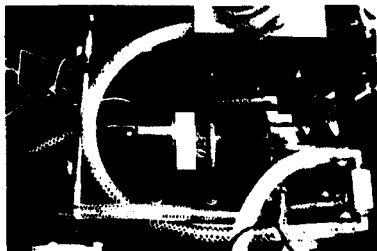

18.

**CAUTION:** When replacing fittings on pump head **DO NOT OVERTIGHTEN** as this could crack inlet and outlet ports in pump head.

**SOLENOID VALVE REMOVAL**

1. Disconnect solenoid valve leads from terminal block.
2. Disconnect solution hoses from solenoid valve.
3. Lay machine on side and remove (2) screws holding valve to chassis.
4. Clean, repair, or replace as required.



19.

**BELT/BRUSH ASSEMBLY REMOVAL**

1. Remove belt guard.



20.

2. Lay machine on side and remove brush pulley guard.



21.

3. Roll belt off motor pulley.
4. Remove (2) screws holding seal plate.



22.

5. Remove screw from each end of brush shaft.
6. Swing brush assembly out of housing to remove belt.

**BRUSH SHAFT/BRUSH BEARING REMOVAL**

1. Remove the large snap ring from brush pulley.
2. Drive the shaft and bearing out from **OPPOSITE** pulley end.

**NOTE:** Insert a 1/4-20 x 2" screw into threaded shaft or use a brass drift to prevent damage to internal threads in shaft.

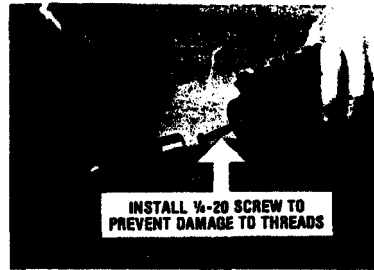

23.

**INSTALLING NEW BRUSH BEARINGS**

1. Install bearing **OPPOSITE** pulley end first.
2. Install shaft making sure **inner** snap ring is on shaft.
3. Install bearing in pulley. Use arbor press or tap in with a hammer and socket.



24.

4. Install the **outer** snap ring on shaft, and bearing retaining snap ring inside pulley.

# COMMODORE 115V

## BRUSH HEAD ASSEMBLY

1. Remove belt guard.
2. Roll belt off motor pulley.
3. Loosen set screws in locking collars on pivot shaft. Slide out shaft to lower brush head assembly.



25.

## BRUSH DRIVE MOTOR

1. To access motor mounting bolts, lower brush head assembly.
2. Disconnect motor leads from terminal block.
3. Remove (4) motor mounting screws.
4. Lift out motor and repair or replace as required.

NOTE: When reinstalling motor, make sure pulleys are properly aligned and belt tension is adjusted to prevent slipping.

## VACUUM SHOE REMOVAL

1. Remove upper link arms.
2. Remove ball joint linkage.
3. Disconnect lift cable from vac shoe.
4. Remove tension springs.
5. Repair or replace as required.

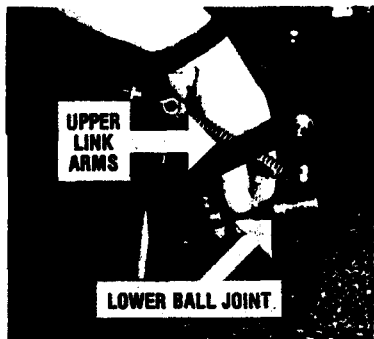

26.

## VAC SHOE ADJUSTMENT

NOTE: When replacing vac shoe or ball joint(s), adjust vac shoe as follows:

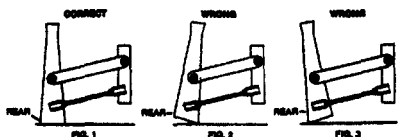

8

With machine on smooth level surface the front and rear shoe of vac casting should be parallel with surface.

1. If front of shoe is off floor (Fig. 3), lengthen lower adjusting rods.
2. If rear of shoe is off floor (Fig. 2), shorten lower adjusting rods.
3. Retighten lock nuts on adjusting rods after completing vac shoe adjustment.

## Vac Shoe Height Adjustment

Place machine on smooth level surface, lower vac shoe. Lever should have approximately 1" of additional forward travel when properly adjusted. Lengthen or shorten lift rods A & B as required (Fig. 4).

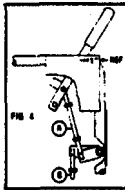

## TO ADJUST VAC SHOE TRACKING

1. With machine moving forward check vac shoe for "tracking."
2. If shoe pulls to the LEFT tighten right hand spring adjusting knob.
3. If shoe pulls to the RIGHT tighten left hand spring adjusting knob.

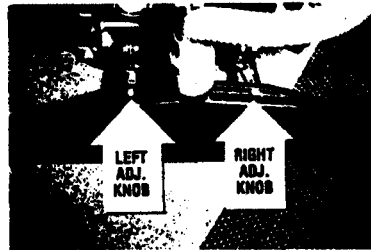

27.

## TRAVERSE DRIVE MOTOR AND CLUTCH REMOVAL

1. Disconnect motor leads.
2. Disconnect leads from clutch coil.
3. Remove chain. NOTE: Chain has master link for easy removal.

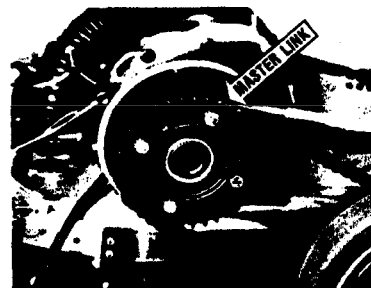

28.

4. Remove (4) bolts holding motor to chassis and lift out motor.
5. Remove brush cap and inspect motor brushes periodically. Brushes should be replaced when they reach 3/8" length or after approximately 750 operating hours. The gear box is sealed and permanently lubricated for the life of motor.

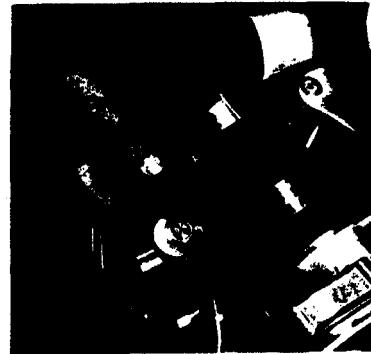

29.

## CLUTCH REMOVAL AND SERVICING

Depending on the duty cycle of the clutch, periodic inspections and cleaning of the clutch parts should be made.

1. Remove bolt from center of gear unit shaft.



30.

2. Remove bolt holding clutch stabilizing arm.



31.

3. Remove sprocket from shaft. Use bearing puller as needed.

## COMMODORE 115V



32.

To check clutch coil resistance—

1. Disconnect machine power cord from outlet.
2. Disconnect clutch lead connection.
3. Set volt/ohm meter to check ohms.
4. Connect meter leads to clutch leads. If the meter reads below 160 ohms or above 195 ohms replace coil.

Accumulation of airborne dust and oils may cause the clutch to slip and lose traction. Remove clutch and clean mating parts with a cleaning solvent.

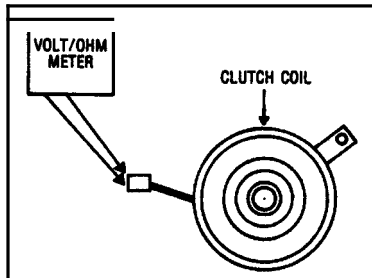

### FRONT AXLE AND WHEEL ASSEMBLY REMOVAL

1. Remove drive chain (see Photo 28).
2. Lay machine on side.
3. Remove nuts and bolts holding flange bearing to frame.



33.

4. Remove axle assembly from machine and put on workbench to service.
5. Remove snap ring on each end of axle to remove wheels.

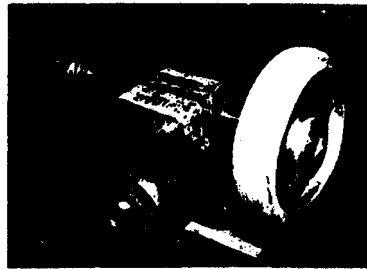

34.

### WHEEL AND AXLE SERVICE/INSTALLATION

1. Install flange bearing on axle. Position set screws (in locking collars) over innermost flats on axle and tighten screws. (Slight adjustment of bearings may be necessary when reinstalling assembly to frame.)
2. When replacing sprocket on axle note dimension — approximately 3 5/16 from end of axle to face of sprocket. (Photo 33)

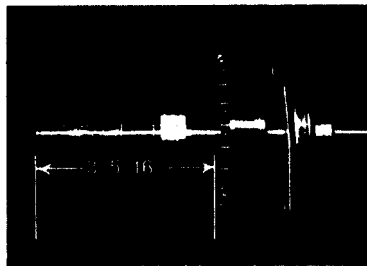

35.

3. Replacing bearing/clutch bearings in wheels. These are directional bearings and must be installed as follows:



36.

**LEFT WHEEL:** Bearing must be pressed in from inboard side of wheel with knurled end of bearing sleeve on inboard side of wheel.



37.

**RIGHT WHEEL:** Bearing must be pressed in from outboard side of wheel with knurled end of bearing sleeve on outboard side of wheel.

**NOTE:** Both right and left bearing assemblies must be pressed in flush with the inside of wheel hubs.

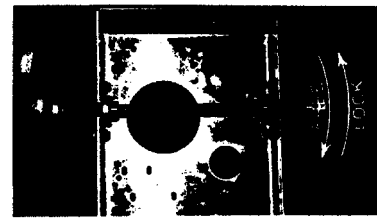

38.

4. To check assembly: hold axle — each wheel should rotate forward freely and lock on shaft when rotation is reversed.

### TESTING COMMODORE ELECTRICAL CIRCUITS:

**CAUTION:** Repairs should only be attempted by qualified personnel since damage can be done by persons not experienced in working with printed circuit boards and components. Testing can be done with an AC/DC volt-ohmmeter.

### SWITCHES AND CIRCUIT BREAKERS

Remove them from machine and use an ohmmeter or continuity tester. The correct reading is zero for an open switch/breaker and infinity (continuity) for a closed switch/breaker.

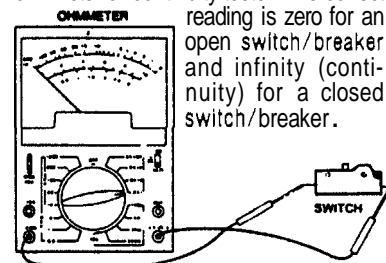

### BRUSH DRIVE MOTOR

This motor operates on a 115V 60 hz circuit (or 230V 50 hz depending on machine model). A 6 amp breaker is installed in the drive motor circuit to prevent damage to the motor in case an overload condition occurs.

If the breaker trips after being reset, check for probable cause:

1. Incorrect power cord. Use nothing less than 12-3 cable wire size and no longer than 100 ft.
2. Brush height lever set too low. Adjust to correct height.
3. Faulty drive motor. Repair or replace as required.
4. Brush assembly "locked-up." Check for obstruction — faulty brush bearings, etc.

# COMMODORE 115V

## SOLID STATE CONTROL BOARD (DC CIRCUIT)

The PC Control Board converts alternating current (AC) to direct current (DC) for the traverse drive motor and clutch solenoid.

A 2 amp slow-blow ceramic fuse is installed in the motor circuit to protect the circuit board and motor in the event an overload condition occurs.

**NOTE:** Always use the same type and size fuse for replacement.

## IF DRIVE MOTOR DOES NOT RUN, CHECK THE FOLLOWING:

1. Check continuity (use ohmmeter) of power cord, drive motor switch, and slow-blow fuse.
2. If fuse blows after replacing, check for short circuit in system or faulty motor. If this does not correct problem the PC Control Board may be faulty.

## To test voltage at PC Control Board:

Plug power cord into properly grounded outlet and press on drive motor switch. Use AC volt meter to check Input voltage at terminals AC and AC on PC Board. Voltage should be 115V (on 115 volt models) and 230V (on 230 volt models). Use DC volt meter to check DC output voltage at terminals A+ and A-. With the speed control knob set at MAX (4) DC volts should be 95 VDC  $\pm$  10%. If there is "0" voltage or the voltage does not remain constant, this is an indication that the circuit board is faulty. Replace as required.

## TO TEST TRAVERSE DRIVE MOTOR:

To test for open or short first disconnect machine power. Use ohmmeter to check resistance between each motor lead in the motor. If leads are infinity (continuity), the motor is grounded, replace gear motor.

To check for shorted armature, use ohmmeter to measure the resistance between the motor leads. If resistance is 5 ohms or less, the armature is short circuited; replace gear motor.

## IF CLUTCH DOES NOT ENGAGE CHECK THE FOLLOWING:

**NOTE:** A 1 amp fast blow fuse is installed in the clutch actuator circuit to protect the PC Control Board in the event an overload condition occurs. The fuse is located in-line near the clutch actuator coil.

1. Check clutch switch (use ohmmeter) for continuity.
2. Check in-line 1 amp fuse. If fuse blows after replacing, the coil is faulty. Replace as required.
3. Use a DC volt meter to check DC voltage to clutch coil at terminals F+ and F- on Control Board. The DC voltage should be 95 VDC  $\pm$  10%. If there is "0" or low voltage or if the voltage does not remain constant, the circuit board is faulty. Replace as required.

## PUMP ASSEMBLY

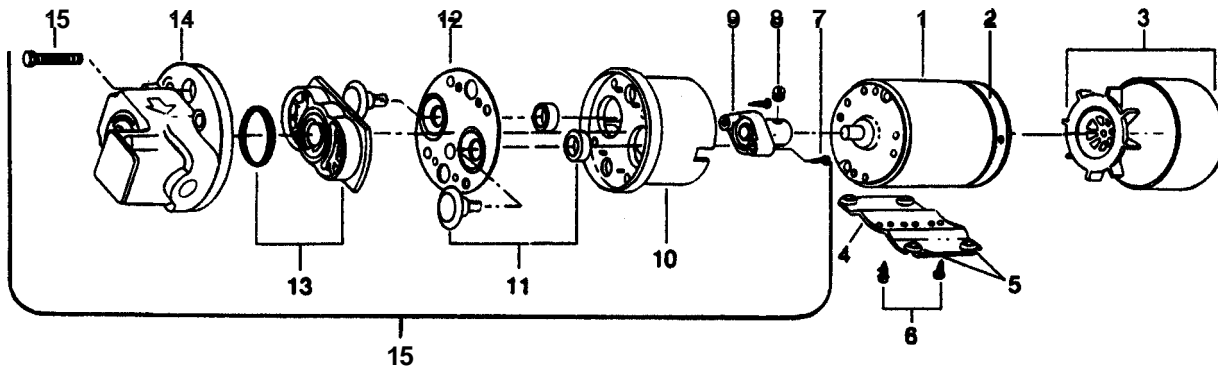

| KEY            | PART NO. | DESCRIPTION                           | KEY | PART NO. | DESCRIPTION                     |
|----------------|----------|---------------------------------------|-----|----------|---------------------------------|
| 1              | 53118    | Motor 115V (for 65067)                | 10  | 27225    | Bearing Cover                   |
| 1A             | 53119    | Motor 230V (for 65070)                | 14  | 41088    | Pump Housing                    |
| 2              | 67071    | Rectifier/End Bell Asm. 115/230V      | 15A | 65071    | Pump Head Asm. 115V (for 65067) |
| 3              | 47075    | Fan/Shroud Asm.                       | 15B | 65072    | Pump Head Asm. 230V (for 65070) |
| 4-5-6          | 47076    | Kit, Base Plate                       |     |          |                                 |
| 7-8-9-11-12-13 | 47087    | Kit Pump Repair (for 65067 and 65070) |     |          |                                 |

# COMMODORE 115V

## CONTROL PANEL ASSEMBLY

| COMMODORE CONTROL E |          |                                      |
|---------------------|----------|--------------------------------------|
| KEY                 | PART NO. | DESCRIPTION                          |
| 1A                  | 23085    | Cord Asm. 12/3 x 75' (110-120V)      |
| 1B                  | 23518    | Cord Asm. 1.5 mm x 75' (220-230V)    |
| 1C                  | 23520    | Cord Asm. 2.5 mm x 75' (240-250V)    |
| 2A                  | 26006    | Cord End. 110-120V Domestic          |
| 2B                  | 26036    | Cord End. 220-230V CEE 7/7 EUR       |
| 2C                  | 26037    | Cord End. 240-250V Australian        |
| 3                   | 73322    | Strain Relief, Cord Hook             |
| 4                   | 70243    | Scr. 8-32 x 1/2 PHMS Blk Nylon       |
| 5                   | 62227    | Plate, Control Panel Access          |
| 6                   | 50143    | Label, Fuse Replacement              |
| 7                   | 50007    | Label, 15A Time Delay                |
| 8A                  | 50331    | Label, Control Panel Wiring 100-120V |
| 8B                  | 50417    | Label, Control Panel Wiring 220-240V |
| 9                   | 57024    | Nut, 3/8-27 Panel                    |
| 10                  | 34160    | Fuseholder, 15A, 250V                |
| 11                  | 34007    | Fuse, 2 Amp Type MDA                 |
| 12                  | 70281    | Scr. 8-32 x 1.0 PHMS                 |
| 13                  | 70228    | Scr. 10-32 x 1/4 PHMS                |
| 14A                 | 72015    | Switch, SPDT Snap Action 100-120V    |
| 14B                 | 72066    | Switch, DPNO Snap Action 220-250V    |
| 15                  | 38134    | Handle, T Switch                     |
| 16                  | 70160    | Scr. 10-32 x 5/8 PHMS                |
| 17                  | 87018    | Washer, #10 Star                     |
| 18                  | 14545    | Bracket, T-Handle                    |
| 19                  | 73429    | Spring, 3/4 x 3/4 Compression        |
| 20                  | 57049    | Nut, 6-32 Lock                       |
| 21A                 | 27123    | Control, 100-120V Speed              |
| 21B                 | 27126    | Control, 220-250V Speed              |
| 22                  | 57104    | Nut, 10-32 w/Star Washer             |
| 23                  | 20015    | Clamp, 9/16 Dia. Nylon               |
| 24                  | 57106    | Nut, 8-32 w/Star Washer              |
| 25                  | 14022    | Terminal Block, 115V 6-6             |
| 25A                 | 14025    | Breaker, 8A Circuit 115V             |
| 25B                 | 14279    | Breaker, 4A Circuit 230V             |
| 27                  | 70322    | Scr. 10-32 x 2 1/4 PHMS              |
| 28A                 | 72004    | Switch, SPST Rocker 110-120V         |
| 28B                 | 72041    | Switch, DPST Rocker 220-250V         |
| 28C                 | 72008    | Switch, SPST Rocker 100V             |
| 29                  | 50371    | Label, CMD Control Panel             |
| 30                  | 70118    | Set Scr. 8-32 x 5/16 KCP             |
| 31                  | 48003    | Knob, Speed Control                  |
| 32                  | 70252    | Scr. 8-32 x 1.0 FHMS Nylon           |
| 33                  | 81121    | Panel, CMD Control                   |
| 34                  | 57107    | Nut, Strain Relief M22.5             |
| 35                  | 57040    | Nut, 1/2 NPT Conduit                 |
| 36                  | 70275    | Scr. 10-32 x 1/2 PHMS Blk Nylon      |
| 37                  | 73201    | Strain Relief, 3/4 NPT               |
| 38                  | 87018    | Washer, #10 x 9/16                   |
| 39                  | 70066    | Scr. 10-32 x 3/4 PHMS                |
| 40                  | 73200    | Strain Relief, 1/2 NPT Flex          |
| 41A                 | 88418    | Wire Asm. 115V                       |
| 41B                 | 88530    | Wire Asm. 220-250V                   |
| 42A                 | 23100    | Cord Asm., Pigtail 100-120V          |
| 42B                 | 23527    | Cord Asm., Pigtail 220-250V          |
| 43A                 | 26015    | Cord End, Male T*Lock 100-120V       |
| 43B                 | 26001    | Cord End, Male T*Lock 220-250V       |
| 44A                 | 26009    | Cord End, Female T*Lock 100-120V     |
| 44B                 | 26012    | Cord End, Female T*Lock 220-250V     |
| 45A                 | 57109    | Nut, 7/16-28 Panel                   |
| 45B                 | 57024    | Nut, 3/8-27 Panel                    |
| 46                  | 57017    | Nut, 15/32-32 Panel                  |
| 47                  | 72083    | Switch, 115 VDC 1A SPST MOM          |
| 48                  | 50776    | Label, For Safety                    |

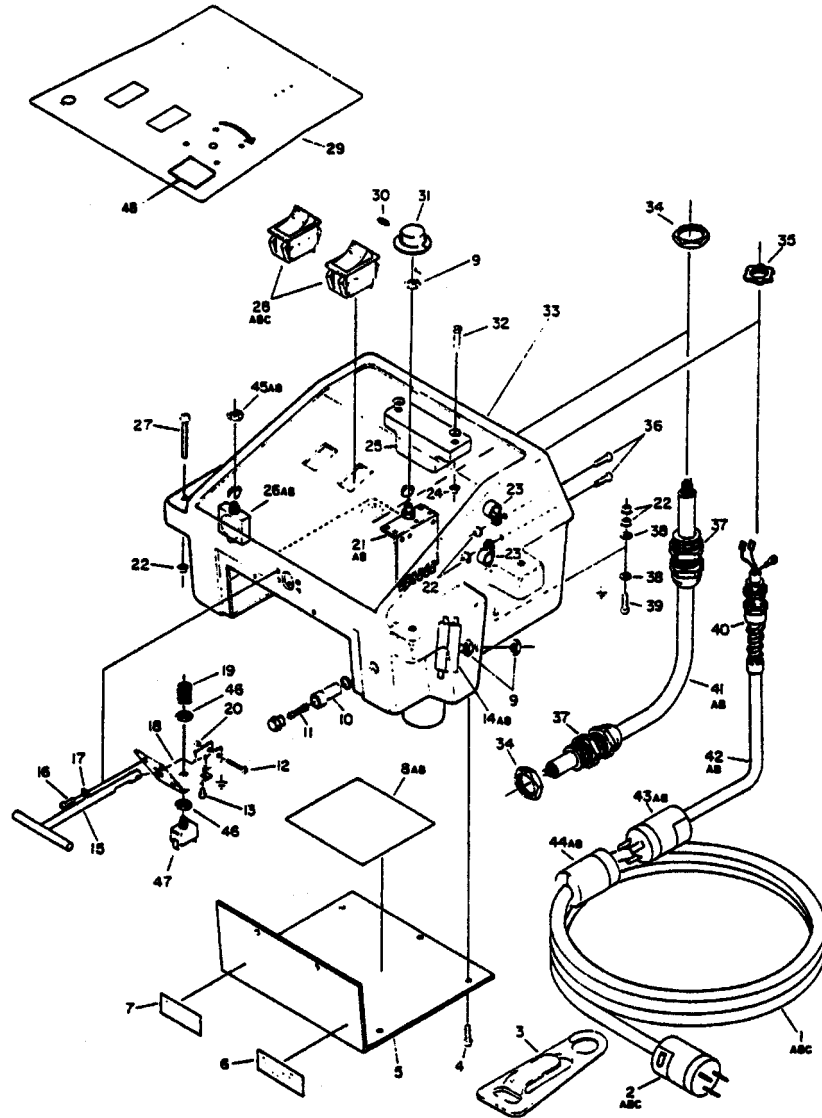

# CHASSIS w/DRIVE ASSEMBLY

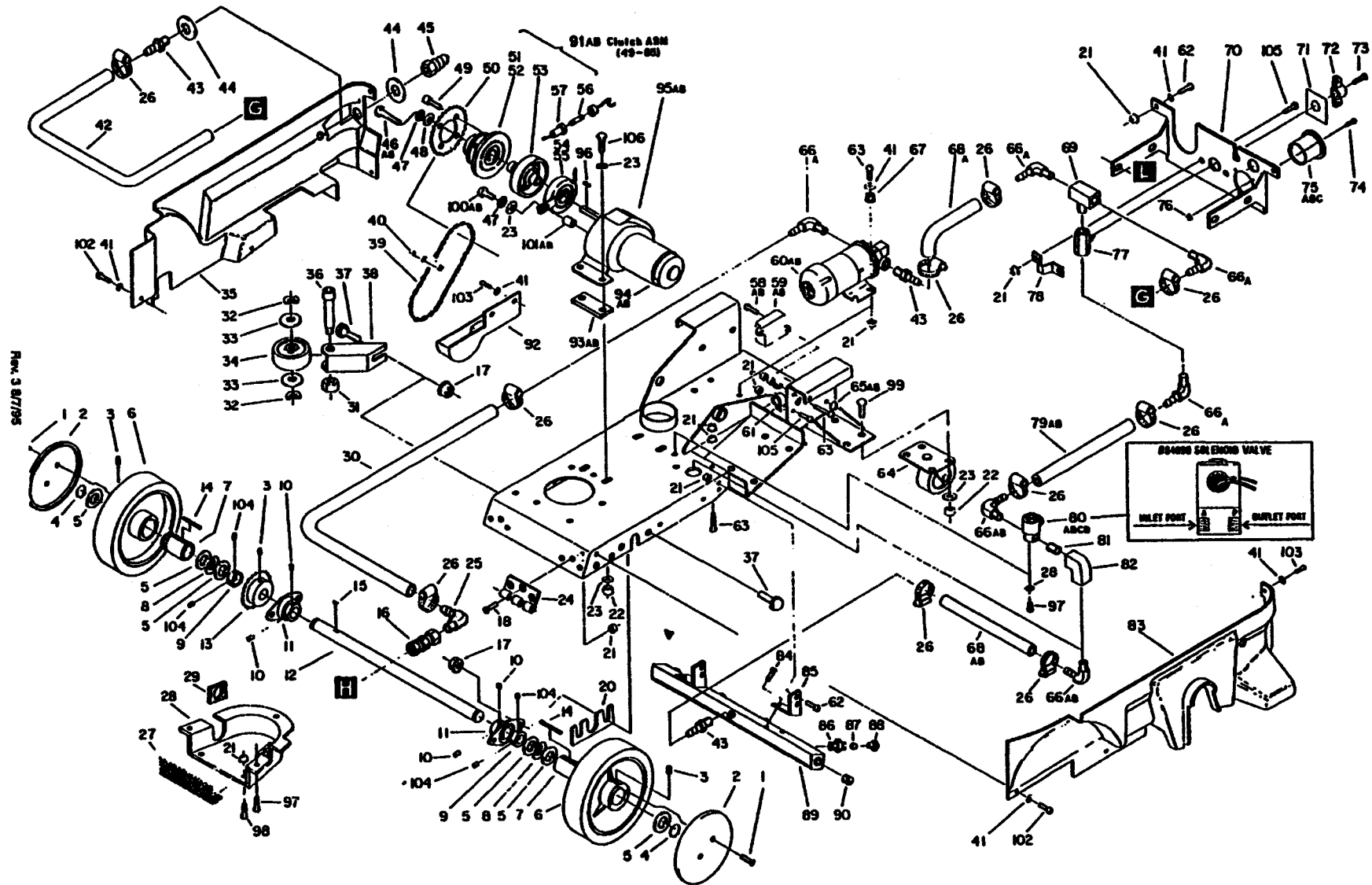

| KEY | PART NO. | DESCRIPTION                   | KEY | PART NO. | DESCRIPTION                   | KEY  | PART NO. | DESCRIPTION                       |
|-----|----------|-------------------------------|-----|----------|-------------------------------|------|----------|-----------------------------------|
| 1   | 70043    | Scr, 10-32 x 5/8 FHMS         | 42  | 39305    | Hose, 3/8 Nylobraid x 24"     | 75C  | 54107    | Meter, 100V Hour                  |
| 2   | 41132    | Hub Cap,CMD black             | 43  | 40014    | Hosebarb, 1/4 MPT x 3/8       | 76   | 57116    | Nut, 6-32 w/Star Washer           |
| 3   | 70119    | Set Scr, 1/4-20 x 3/8 KCP     | 44  | 87015    | Washer, 9/16 ID x 1.06 OD     | 77   | 84065    | Valve, Solution w/Knob            |
| 4   | 67010    | Ring, 5/8 Ext. Snap           | 45  | 56012    | Nipple, 1/4 FPT OD            | 78   | 14454    | Bracket, Valve                    |
| 5   | 67012    | Race, Thrust                  | 46A | 70105    | Scr, 1/4-20 x 1.75 HHMS       | 79A  | 39207    | Hose, 3/8 Nylobraid x 16"         |
| 6   | 89019    | Wheel,CMD machined            | 46B | 70022    | Scr, 1/4-20 x 2 HHMS          | 79B  | 39350    | Hose, 3/8 Nylobraid x 21.5"       |
| 7   | 09011    | Bearing Asm., Wheel           | 47  | 87025    | Washer, 1/4 Star              | 80A  | 84098    | Valve, 115V Solenoid              |
| 8   | 87038    | Washer, 5/8 Wave              | 48  | 87008    | Washer, 1/4 ID x 1 1/4 OD     | 80B  | 84099    | Valve, 230V Solenoid              |
| 9   | 27122    | Collar, Shaft                 | 49  | 70094    | Scr, 1/4-20 x 1/2 SHCS        | 80C  | 84100    | Valve, 240V Solenoid              |
| 10  | 70126    | Set Scr., 1/4-28 x 1/4 KCP    | 50  | 73367    | Sprocket, 3/8 Pitch           | 80D  | 84101    | Valve, 100V Solenoid              |
| 11  | 09005    | Bearing, 5/8 Flange           | 51  | 05057    | Clutch Armature, w/Bearing    | 81   | 56014    | Nipple, 1/4 Close                 |
| 12  | 03012    | Axle, Wheel                   | 52  | 09048    | Bearing, Clutch Armature      | 82   | 31017    | Elbow, 1/4 FPT                    |
| 13  | 73045    | Sprocket, #35 3/8" P 25 beth  | 53  | 67209    | Rotor, Clutch                 | 83   | 73243    | Skirt, Left                       |
| 14  | 48008    | Key, 3/16 x 1.75              | 54  | 09049    | Bearing, Clutch Magnet        | 84   | 70114    | Scr, #10 x 3/4 Polyfast           |
| 15  | 48006    | Key, #9 Woodruff              | 55  | 54108    | Magnet, w/Bearing             | 85   | 14600    | Bracket, Manifold Mounting        |
| 16  | 22012    | Coupler, 3/8 OD St-Thru       | 56  | 34447    | Fuse, 1.0 A Type AGC          | 86   | 44052    | Jet Body, Mini Quick w/Seat       |
| 17  | 57032    | Nut, 3/8 Flange Lock          | 57  | 34146    | Fuseholder, Inline            | 87   | 44051    | Jet Seal, Quick Change            |
| 18  | 70043    | Scr., 10-32 x 3/4 FHMS        | 58A | 70045    | Scr, 8-32 x 1 PHMS            | 88   | 44062    | Jet, 110015 Quick Change          |
| 19  | _____    | _____                         | 58B | 70016    | Scr, 6-32 x 3/4 PHMS          | 89   | 54105    | Manifold, CMD ABS                 |
| 20  | 62041    | Plate, Axle Bearing           | 59A | 14462    | Term Block, 25A 250V 4-4-8    | 90   | 66095    | Plug, 1/8 NPT Slotted             |
| 21  | 57104    | Nut, 10-32 w/Star Washer      | 59B | 76056    | Term Strip, 300V 20A 12 Pos   | 91A  | 27315    | Clutch Asm, Magnetic 100-115V D.I |
| 22  | 57047    | Nut, 1/4-20 Lock              | 60A | 65087    | Pump, 100-120V                | 91B  | 27479    | Clutch Asm, Magnetic 230-240V     |
| 23  | 87013    | Washer, 1/4 ID x 5/8 OD       | 60B | 65101    | Pump, 220-240V                | 92   | 36069    | Guard, CMD Chain                  |
| 24  | 41012    | Hinge, 3 x 3 butt plate       | 61  | 20015    | Clamp, 9/16 Dia. Nylon        | 93A  | 73369    | Spacer, VW Motor 100-120V         |
| 25  | 40034    | Hosebarb, 3/8 MPT x 3/8 90 D  | 62  | 70088    | Scr, 10-32 x 1/2              | 93B  | 73395    | Spacer, Bodine Motor 220-240V     |
| 26  | 20016    | Clamp, Hose                   | 63  | 70066    | Scr, 10-32 x 3/4 PHMS         | 94A  | 14287    | Brush Set, VW 110-120V            |
| 27  | 73408    | Screen, Vac Duct              | 64  | 18011    | Caster, 3" dia. swivel mchnd. | 94B  | 140097   | Brush set, drive motor 53002      |
| 28  | 29147    | Duct, Vac Cooling             | 65A | 57106    | Nut, 8-32 w/Star Washer       | 95A  | 53551    | Motor, Asm., drive 110V VW        |
| 29  | 34180    | Filter, Vac Duct              | 65B | 57116    | Nut, 6-32 w/Star Washer       | 95B  | 53552    | Motor Asm, drive 230V Bodine      |
| 30  | 39304    | Hose, 3/8 Nylobraid x 36"     | 66A | 40033    | Hosebarb, 1/4 MPT x 3/8 90 D  | 96   | 48007    | Key, Drive Motor                  |
| 31  | 57113    | Nut, 5/16-18 Lock             | 66B | 40031    | Hosebarb, 1/8 MPT x 3/8 90 D  | 97   | 70234    | Scr, 10-32 x 3/8 PHST -F-         |
| 32  | 87074    | Washer, 3/8 ID x .010 Wave    | 67  | 36006    | Grommet, pump base            | 98   | 70162    | Scr, 10-32 x 3/8 PHMS             |
| 33  | 87030    | Washer, 3/8 ID x 3/4 OD Nylon | 68A | 39036    | Hose, 3/8 Nylobraid x 12"     | 99   | 70015    | Scr, 1/4-20 x 3/4 HHMS            |
| 34  | 89017    | Wheel, Guide                  | 68B | 39361    | Hose, 3/8 Nylobraid x 7.5"    | 100A | 70022    | Scr, 1/4-20 x 2 HHMS              |
| 35  | 73242    | Skirt, Right                  | 69  | 78024    | Tee, 1/4 Branch               | 100B | 70365    | Scr, 1/4-28 x 1.00 HHMS           |
| 36  | 70002    | Shoulder Bolt, 3/8 OD x 2.0 L | 70  | 61115    | Panel, Rear                   | 101A | 73368    | Spacer, CMD Clutch 100-120V       |
| 37  | 70102    | Scr., 3/8-16 x 3/4            | 71  | 50328    | Label, Valve Position         | 101B | 73394    | Spacer, CMD Clutch 220-240V       |
| 38  | 14461    | Bracket, Guide Wheel          | 72  | 48028    | Knob, Ball Valve              | 102  | 70110    | Scr, 10-24 x 3/4 PHST -F-         |
| 39  | 27325    | Chain, CMD Drive II           | 73  | 70091    | Scr, 10-24 x 1/2 FHMS         | 103  | 70187    | Scr, 10-24 x 1/2 PHST -F-         |
| 40  | 51010    | Master Link, #35              | 74  | 70056    | Scr, 6-32 x 1/2 PHMS          | 104  | 70314    | Set Scr, 5/16-18 x 1/4 KCP        |
| 41  | 87018    | Washer, #10 x 9/16 OD         | 75A | 54012    | Meter, 115V Hour              | 105  | 70160    | Scr, 10-32 x 5/8 PHMS             |
|     |          |                               | 75B | 54011    | Meter, 220-240V Hour          | 106  | 70249    | Scr, 1/4-20 x 1.25 HHMS           |

RAW 3 8/7/95

# CHASSIS w/HANDLE ASSEMBLY

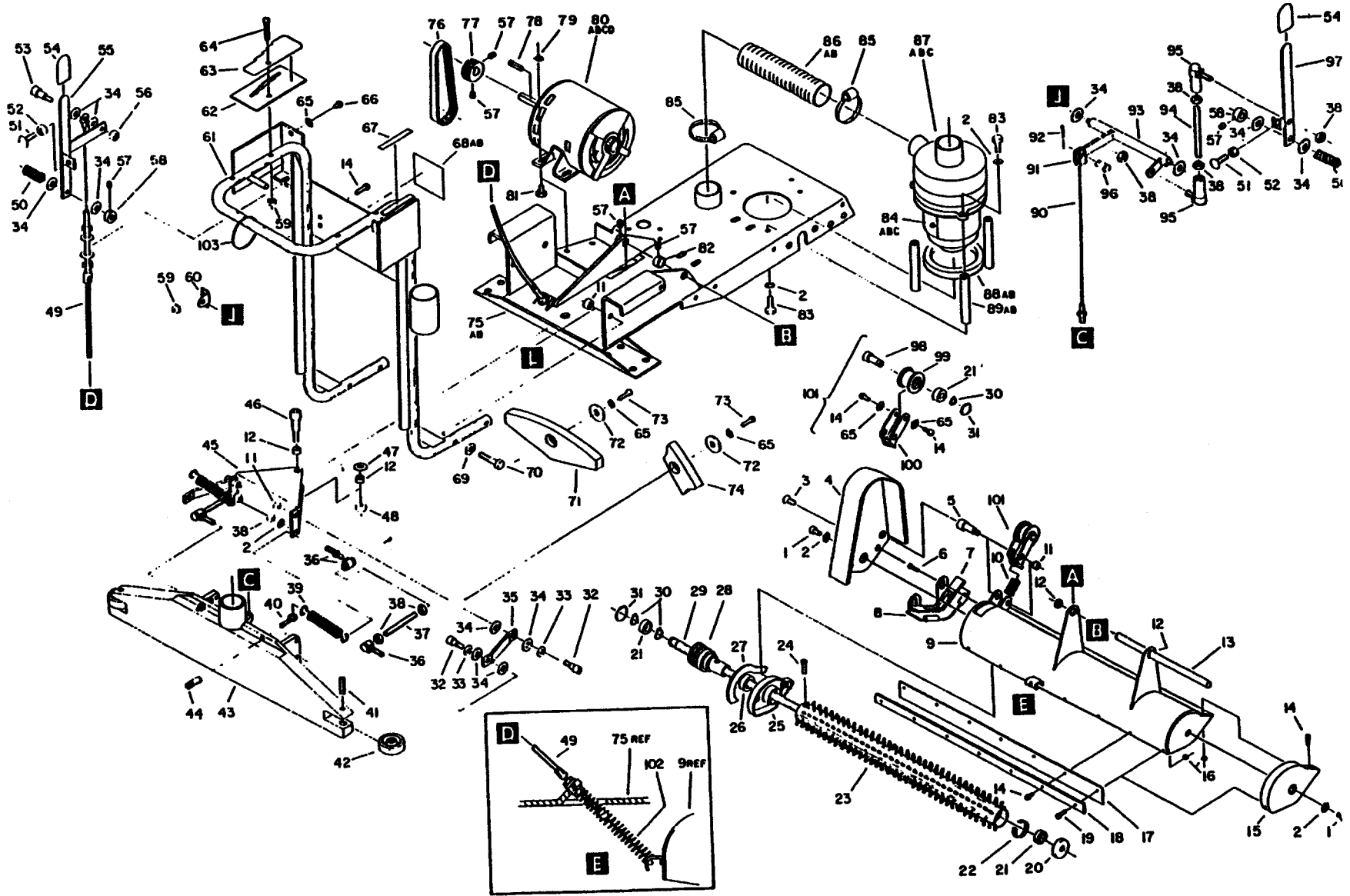

| KEY | PART NO. | DESCRIPTION                     |
|-----|----------|---------------------------------|
| 1   | 70085    | Scr., 1/4-20 x 1/2 PHMS         |
| 2   | 87025    | Washer, 1/4 Star                |
| 3   | 70274    | Scr., 5/16-18 x 1/2 FHMS        |
| 4   | 36071    | Guard, Bolt                     |
| 5   | 70267    | Shoulder Bolt, 5/16 OD x 1.25 L |
| 6   | 70067    | Scr., 6-32 x 3/8 PHMS           |
| 7   | 35083    | Gasket, Pulley Guard            |
| 8   | 36068    | Guard, Brush Pulley             |
| 9   | 41129    | Housing, Brush                  |
| 10  | 73245    | Spring, 2" Compression          |
| 11  | 57047    | Nut, 1/4-20 Lock                |
| 12  | 09025    | Bearing, 1/2 ID Nylon           |
| 13  | 03041    | Axle, Brush Housing Pivot       |
| 14  | 70088    | Scr., 10-32 x 1/2 PHMS          |
| 15  | 27281    | Cap, Brush Housing End          |
| 16  | 57090    | Nut, 10-32 Lock                 |
| 17  | 36070    | Guard, Splash                   |
| 18  | 67106    | Retainer, Splash Guard          |
| 19  | 70066    | Scr., 10-32 x 3/4 PHMS          |
| 20  | 36054    | Guard, Thread                   |
| 21  | 09019    | Bearing, Brush                  |
| 22  | 67098    | Ring, Tolerance                 |
| 23  | 12006    | Brush                           |
| 24  | 70177    | Scr., 1632 x 1/2 FHMS           |
| 25  | 62171    | Plate, Pulley Seal              |
| 26  | 73241    | Seal, Pulley                    |
| 27  | 35085    | Gasket, Seal Plate              |
| 28  | 64041    | Pulley, Brush                   |
| 29  | 03040    | Axle, Brush                     |
| 30  | 67094    | Snap Ring, 1/2 External         |
| 31  | 67093    | Snap Ring, 1.12 Internal        |
| 32  | 70078    | Shoulder Bolt, 5/16 OD x 3/8 L  |
| 33  | 87029    | Washer, 5/16 ID x 3/4 OD        |
| 34  | 87030    | Washer, 3/8 ID x 3/4 OD Nylon   |
| 35  | 05021    | Arm, Vac Shoe Upper             |
| 36  | 14029    | Ball Joint, 1/4-28 HD           |
| 37  | 05003    | Arm, Vac Shoe Lower Adj.        |
| 38  | 57029    | Nut, 1/4-28 Hex                 |
| 39  | 73240    | Spring, 2.25 Extension          |

| KEY | PART NO. | DESCRIPTION                        |
|-----|----------|------------------------------------|
| 40  | 70263    | Eye Bolt, 8.32 x 1.0 x 1/4         |
| 41  | 66094    | Pin, 1/4 OD x 1.38 Roll            |
| 42  | 89051    | Wheel, Vac Shoe Bumper             |
| 43  | 85017    | Vac Shoe                           |
| 44  | 48031    | Knob, Vac Shoe Adjustment          |
| 45  | 14447    | Bracket, Vac Shoe Swivel           |
| 46  | 70269    | Shoulder Bolt, 1/2 x 2.0 L         |
| 47  | 87031    | Washer, .53 ID x 1.5 OD Teflon     |
| 48  | 57022    | Nut, 3/8-16 Lock                   |
| 49  | 27278    | Cable, Brush Lift                  |
| 50  | 73043    | Spring, 1.5 Compression            |
| 51  | 70291    | Scr., 1/4-20 x 1.5 Flt Carriage    |
| 52  | 57065    | Nut, 1/4-20 Jam                    |
| 53  | 70272    | Shoulder Bolt, 3/8 x 3/8 L         |
| 54  | 36004    | Grip, Vinyl Handle                 |
| 55  | 38125    | Handle, Brush Adjustment           |
| 56  | 57031    | Nut, 5/16-18 Hex                   |
| 57  | 70126    | Set Scr., 1/4-20 x 1/4 KCP         |
| 58  | 27063    | Collar, 3/8 Shaft                  |
| 59  | 57104    | Nut, 10-32 w/Star Washer           |
| 60  | 14062    | Bracket, Vac Lift Arm              |
| 61  | 38139    | Handle, Main (Photo Mount Housing) |
| 62  | 62228    | Plate, Brush Handle                |
| 63  | 50373    | Label, CMD Brush Adj.              |
| 64  | 70021    | Scr, 10-32 x 2 PHMS                |
| 65  | 87016    | Washer, #10 Star                   |
| 66  | 70162    | Scr, 10-32 x 3/8 PHMS              |
| 67  | 50138    | Label, Vacuum On/Off               |
| 68A | 50330    | Label, CMD Chassis Wiring 100-120V |
| 68B | 50418    | Label, CMD Chassis Wiring 220-240V |
| 69  | 87013    | Washer, 1/4 ID x 5/8 OD            |
| 70  | 70010    | Scr, 1/4-20 x 1.5 HHMS             |
| 71  | 89054    | Weight, CMD Center Vac Shoe        |
| 72  | 87008    | Washer, 1/4 ID                     |
| 73  | 70042    | Scr, 10-24 x 1.0 HHMS              |
| 74  | 89060    | Weight, CMD Right and Left         |
| 75A | 34139    | Frame, CMD 100-120V                |
| 75B | 34177    | Frame, CMD 220-240V                |
| 76  | 11019    | Bell, CMO Brush Drive              |

| KEY | PART NO. | DESCRIPTION                       |
|-----|----------|-----------------------------------|
| 77  | 64022    | Pulley, Poly-V Belt               |
| 78  | 48011    | Key, 1/8 x 3/16 x 1               |
| 79  | 57060    | Nut, 1/4-20 Captive               |
| 80A | 53093    | Motor, Brush Drive 115V           |
| 80B | 53154    | Motor, Brush Drive 230V           |
| 80C | 53165    | Motor, Brush Drive 240V           |
| 80D | 53173    | Motor, Brush Drive 100V           |
| 81  | 70015    | Scr, 1/4-20 x 3/4 HHMS            |
| 82  | 27279    | Collar, Brush Pivot Axle          |
| 83  | 70011    | Scr, 1/4-20 x 5/8 HHMS            |
| 84A | 14035    | Brush Set, CMD Vac Motor 115V     |
| 84B | 14659    | Brush Set, CMD Vac Motor 220-240V |
| 84C | 14660    | Brush Set, CMD Vac Motor 100V     |
| 85  | 20064    | Clamp, 2.0" Worm Gear x .31       |
| 86A | 39298    | Hose, Vac Exhaust 100-120V        |
| 86B | 39351    | Hose, Vac Exhaust 220-240V        |
| 87A | 53708    | Vac Motor, 115V 7.2 3 Stage       |
| 87B | 53709    | Vac Motor, 220-240V 7.2 3 Stage   |
| 87C | 53715    | Vac Motor, 100V 7.2 2 Stage       |
| 88A | 35033    | Gasket, Vac Motor 100-120V        |
| 88B | 35067    | Gasket, Vac Motor 220-240V        |
| 89A | 73001    | Spacer, Vac Mounting 100-120V     |
| 89B | 73396    | Spacer, Vac Mounting 220-240V     |
| 90  | 27273    | Cable, Vac Shoe Lift              |
| 91  | 27285    | Clevis, Full                      |
| 92  | 66073    | Pin, 1/16 x 3/4 Cotter            |
| 93  | 05020    | Arm, Vac Shoe Lift                |
| 94  | 67018    | Rod, Upper Linkage                |
| 95  | 14052    | Ball Joint                        |
| 96  | 66096    | Pin, 1/4 OD c 3/4 Clevis          |
| 97  | 38127    | Handle, Vac Lift                  |
| 98  | 03042    | Axle, Idler Pulley                |
| 99  | 64040    | Pulley, Idler                     |
| 100 | 14455    | Bracket, Idler Arm                |
| 101 | 64042    | Pulley, Assembly, Idler           |
| 102 | 73244    | Spring, 3.5 L Compression         |
| 103 | 67147    | Ring, 2" Split                    |

**SOLUTION/RECOVERY TANKS**

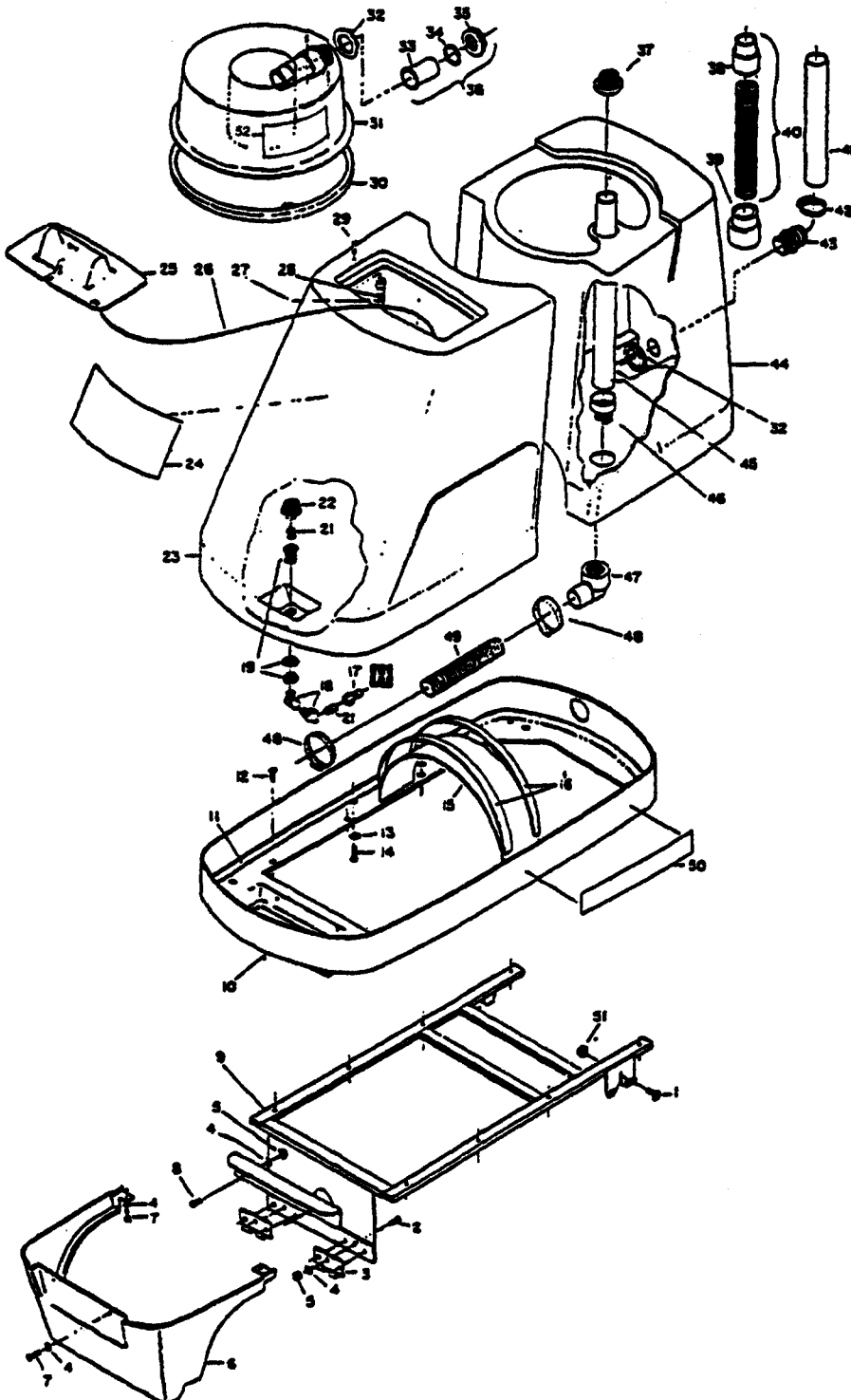

| COMMODORE TANKS |          |                                   |
|-----------------|----------|-----------------------------------|
| KEY             | PART NO. | DESCRIPTION                       |
| 1               | 70103    | Scr., 1/4-20 x 1.0 THMS           |
| 2               | 70066    | Scr., 10-32 x 3/4 FHMS            |
| 3               | 41012    | Minge, 3 x 3 Butt plate           |
| 4               | 87018    | Washer, #10 x 9/16 OD             |
| 5               | 57030    | Nut, 10-32, Lock                  |
| 6               | 73246    | Skirt, Nose                       |
| 7               | 70111    | Scr., 10-32 x 1/2 PHST            |
| 8               | 70043    | Scr., 10-32 x 5/8 FHMS            |
| 9               | 34007    | Frame, Tank Support               |
| 10              | 66097    | Pan, Tank                         |
| 11              | 35038    | Gasket, Sol/Rec Tank Pan          |
| 12              | 70003    | Scr., 10-24 x 5/8 PHST            |
| 13              | 87040    | Washer, Tank Mounting             |
| 14              | 70011    | Scr., 1/4-20 x 5/8 FHMS           |
| 15              | 38023    | Guard, Tank Drip                  |
| 16              | 35037    | Gasket, Sol/Rec Seal              |
| 17              | 58008    | Nipple, 3/8 FPT SR Thru GD        |
| 18              | 31023    | Elbow, 3/8 NPT 45 D Street        |
| 19              | 14007    | Bushing w/ Nut, 3/8 FPT x 1 MPT   |
| 21              | 58010    | Nipple, 3/8 Close                 |
| 22              | 73088    | Strainer, 3/8 FPT 80 Mesh         |
| 23              | 75120    | Tank, Solution                    |
| 24              | 50329    | Label, CMO Main                   |
| 25              | 51056    | Lid, Tank w/ Cord                 |
| 26              | 27007    | Cord, 24"                         |
| 27              | 50149    | Label, Scale                      |
| 28              | 73094    | Scale, Tank                       |
| 29              | 70114    | Scr., #10 x 3/4 Polytess          |
| 30              | 35016    | Gasket, Dome                      |
| 31              | 28014    | Dome, Includes 31, 32, 38         |
| 32              | 57039    | Nut, 1.5 NPT Flange               |
| 33              | 78034    | Tube, 1.5 OD x 2.5 L              |
| 34              | 35002    | Gasket, Intake                    |
| 35              | 57033    | Nut, 1.5 Slip Joint               |
| 36              | 28008    | Intake Tube Assembly              |
| 37              | 34140    | Filter, 10 Mesh Vacuum            |
| 38              | 27284    | Cuff, 1.5 Swivel SMB Hose         |
| 39              | 27283    | Cuff, 2" Slip x 1.5 Hose          |
| 40              | 38295    | Hose Ass., 1.5 SMB w/ Swivel Cuff |
| 41              | 38326    | Hose, 1.5 Drain x 25.5"           |
| 42              | 20002    | Clamp, 2" Nylon Ratchet           |
| 43              | 40001R   | Hose Barb, 1.5 MPT x 1.5          |
| 44              | 73121    | Tank, Recovery                    |
| 45              | 78008    | Tube, 1.5 PVC x 18.5 L            |
| 46              | 04032    | Adapter, 1.5 MPT x 1.5 FS PVC     |
| 47              | 31059    | Elbow, PVC 1 1/2 FPT x M Slip     |
| 48              | 20046    | Clamp, 2.25" Hose                 |
| 49              | 39333    | Hose, 2" Wirebound Vac x 20"      |
| 50              | 50333    | Label, COMMODORE                  |
| 51              | 57047    | Nut, 1/4-20 NY-Lock               |
| 52              | 50742    | Label, Warning Explosion horiz.   |

COMMODORE 115V

CONTROL PANEL WIRING DIAGRAM 115 VOLT

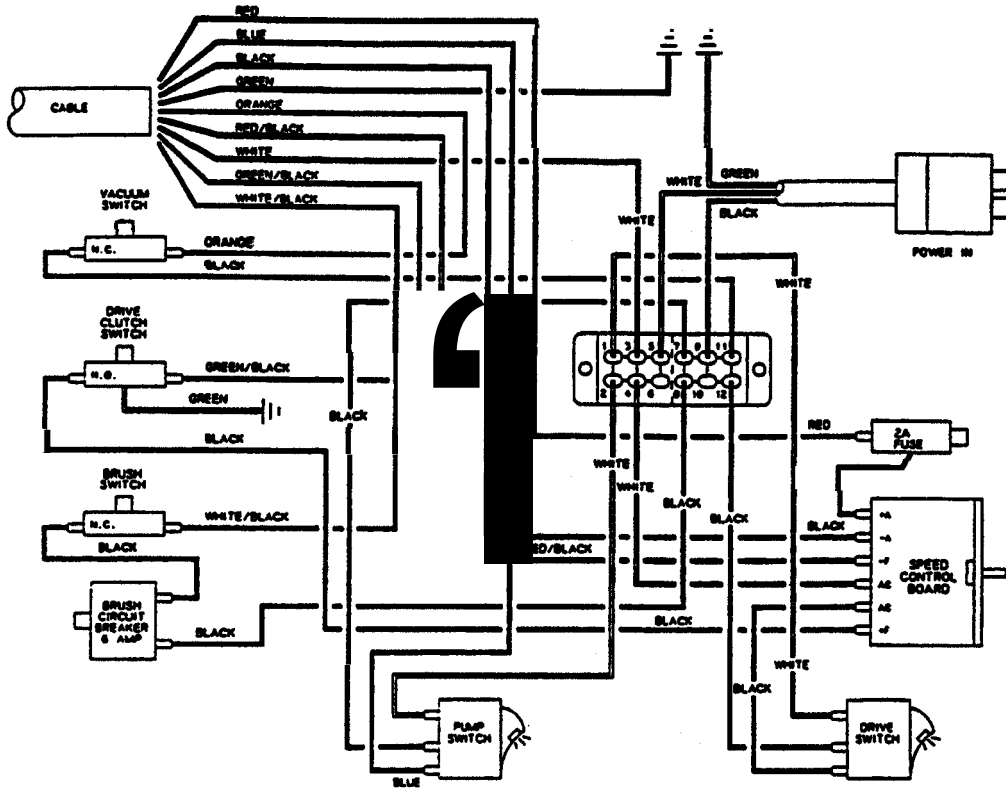

CHASSIS WIRING DIAGRAM 115 VOLT

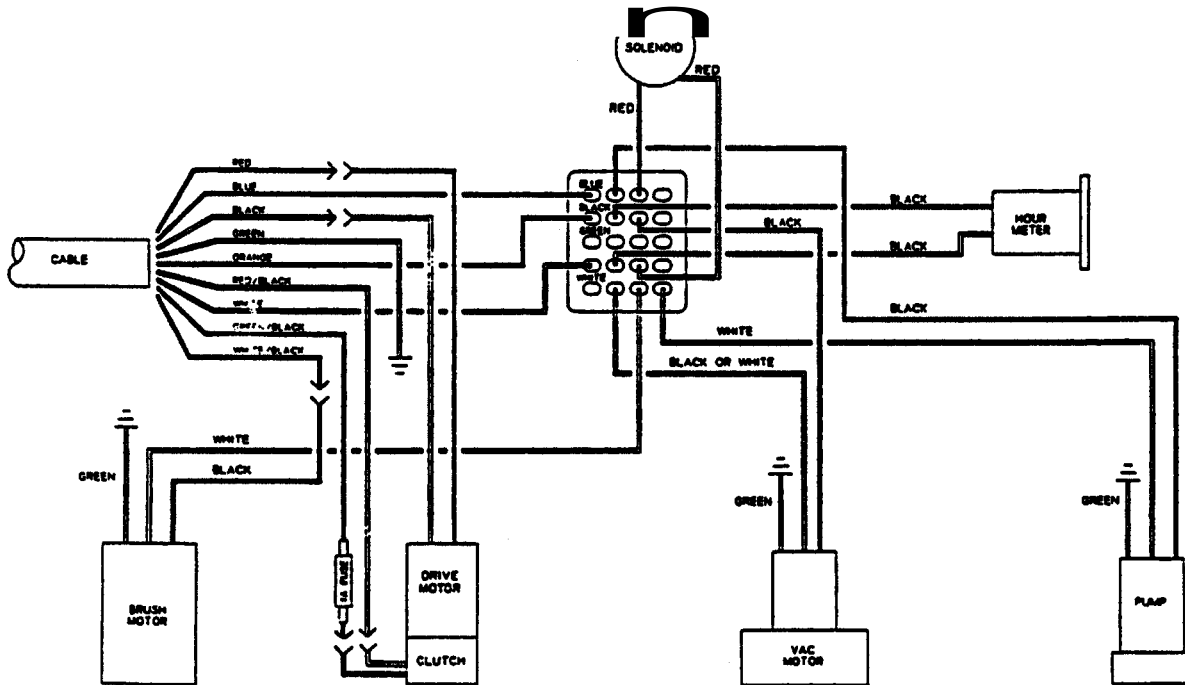

# COMMODORE 115V

## CONTROL PANEL WIRING DIAGRAM 230 VOLT

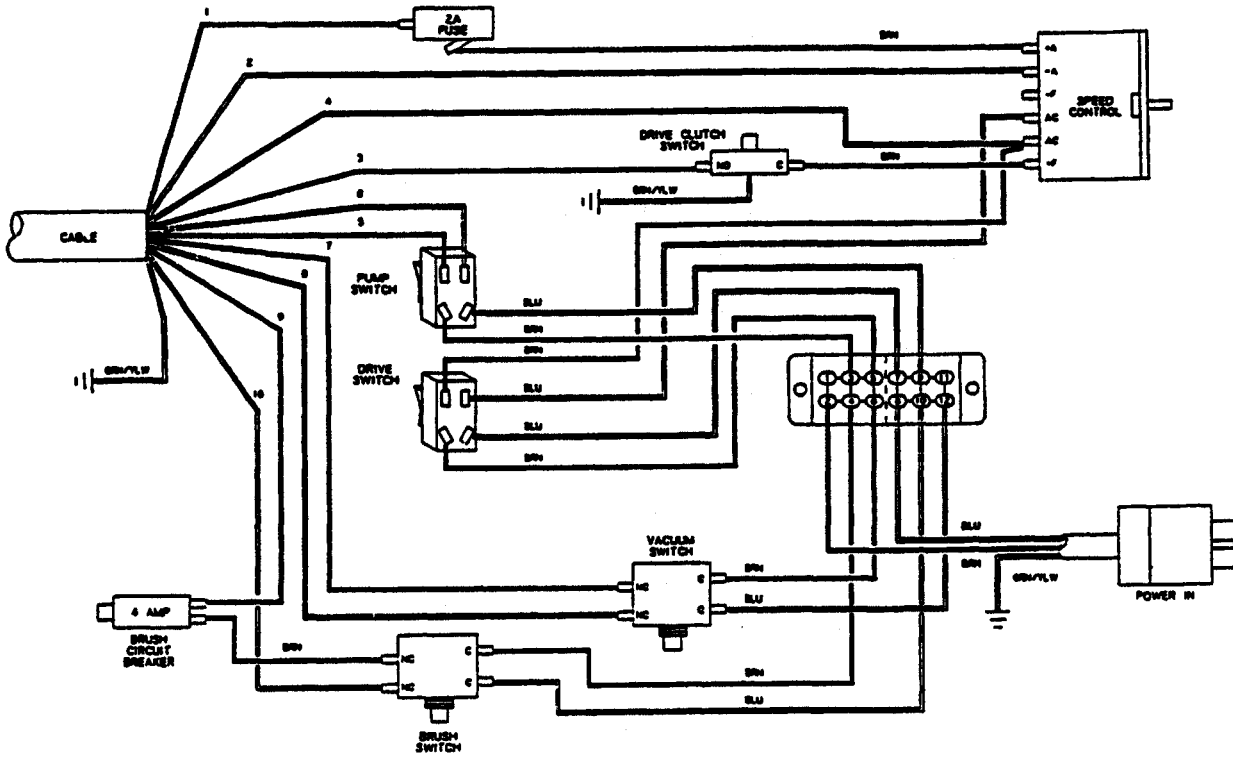

## CHASSIS WIRING DIAGRAM 230 VOLT

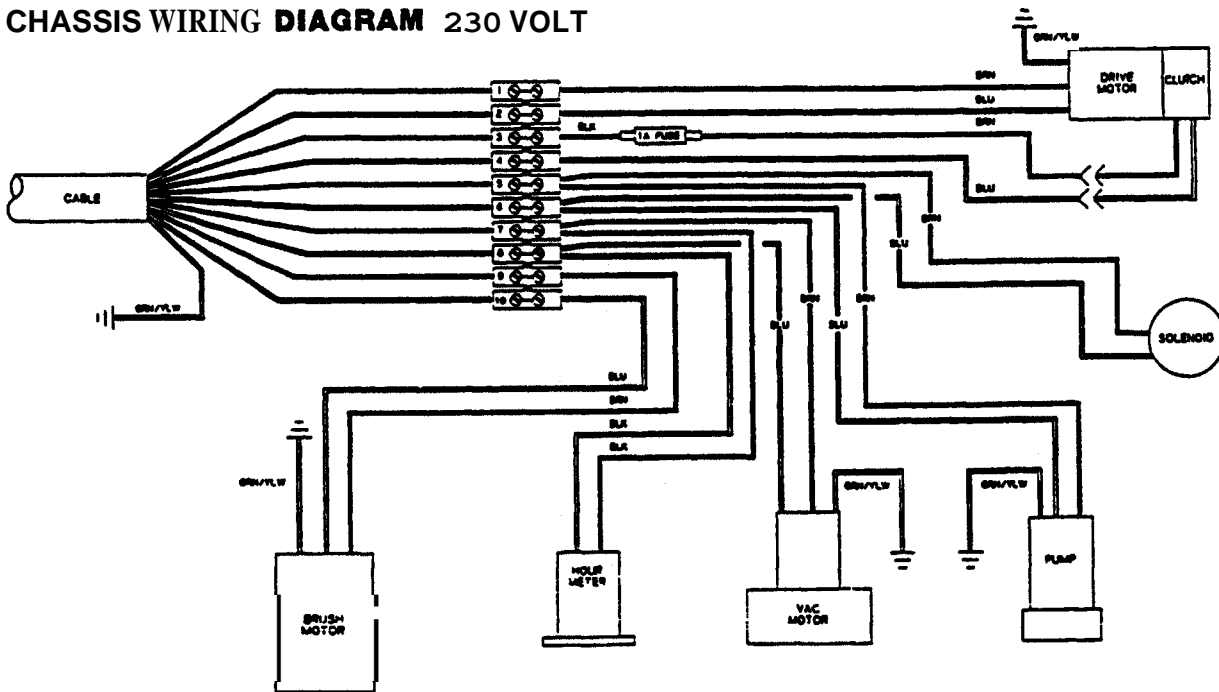

# COMMODORE 115V

| COMMODORE TROUBLE-SHOOTING GUIDE      |  |   |
|---------------------------------------|--|---|
| PROBLEM                               | CAUSE  | SOLUTION  |
| No electrical power.                  | Dead electrical circuit.   | Check building circuit breaker or fuse box.                               |
|                                       | Faulty <b>main</b> power switch on machine.                          | Replace switch.   |
|                                       | Faulty power cord.   | Repair or replace power cord,   |
|                                       | Fuse blown or circuit breaker tripped (on machine).                  | <del>Replace</del> fuse or reset breaker <i>after</i> correcting problem. |
| Loss of vacuum/<br>solution recovery. | Vacuum lever in "off" position.                                      | Put lever in "on" position.   |
|                                       | Faulty <b>vac</b> motor switch.                                      | Replace switch.   |
|                                       | Worn <b>vac</b> motor brushes or faulty <b>vac</b> motor.            | Replace motor brushes or motor.   |
|                                       | Crack in recovery dome.  | Repair or replace.  |
|                                       | Obstruction or damage in <b>vac</b> shoe linkage or <b>vac</b> hose. | Remove obstruction, repair or replace <b>vac</b> casting.                 |
|                                       | Incorrectly installed or adjusted <b>vac</b> shoe.                   | Adjust <b>vac</b> shoe.   |
| No forward movement<br>of machine.    | Loose wires at switch or connections.                                | Repair as required.   |
|                                       | Faulty drive motor switch.   | Replace switch.   |
|                                       | Worn carbon brushes in gear drive motor or faulty motor.             |   |
|                                       | Fuse blown or circuit breaker tripped (on machine).                  | Replace fuse or reset breaker after correcting problem.                   |
|                                       | Faulty speed control potentiometer.                                  | Replace control.  |
| No solution flow.                     | Faulty pump.   | Replace pump.   |
|                                       | Faulty switch.   | Replace switch.   |
|                                       | "Clogged" or faulty solenoid.  | Remove obstruction or replace.  |
|                                       | Obstruction in jets.   | Remove and clean jets.  |
| Solution will not<br><b>shut</b> off. | Faulty switch.   | Replace switch.   |
|                                       | Dirt in solenoid valve or faulty valve.                              | Remove obstruction or replace valve.                                      |
| Uneven cleaning.                      | One or more jets plugged.  | Clean jets.   |