

# ADMIRAL™ PLUS

CARPET EXTRACTOR

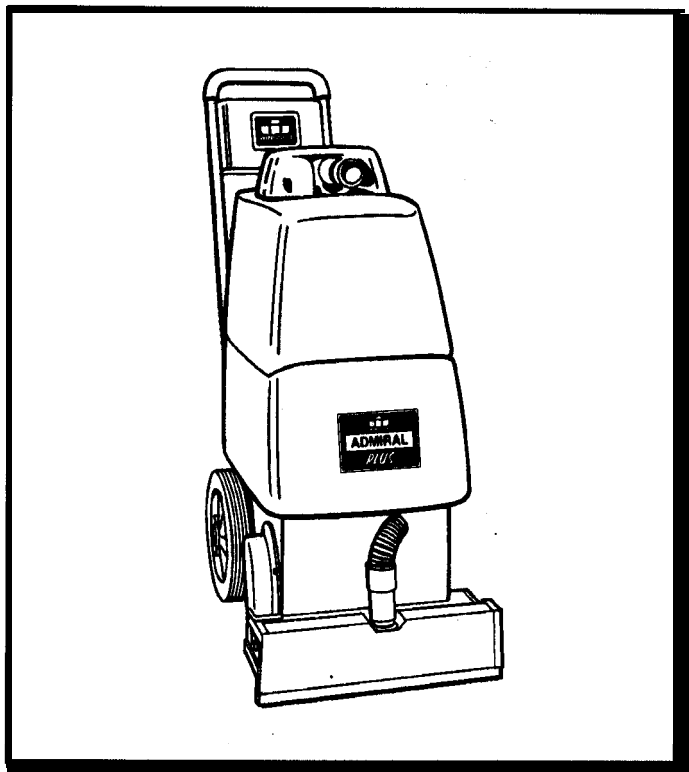

Operating Instructions (ENG)

Models: ADP, ADPJ

**QUEST** ... for Continuous Improvement.  
Windsor's Quality Management System is Certified **ISO 9001**.



UL LISTING COVERS ADP ONLY

*Read these instructions before operating the machine.*

 **CLICK TO ORDER PARTS**

# IMPORTANT SAFETY INSTRUCTIONS

When using an electrical appliance, basic precautions should always be followed, including the following:

## READ ALL INSTRUCTIONS BEFORE USING MACHINE



**WARNING** – To reduce the risk of fire, electric shock, or injury:

- Connect machine to a properly grounded outlet only. See grounding instructions.
- Do not leave appliance when plugged in. Unplug from outlet when not in use and before servicing.
- Use indoors only. Do not use outdoors or expose to rain.
- Do not allow to be used as a toy. Close attention is necessary when used by or near children.
- Use only as described in this manual. Use only manufacturer's recommended attachments.
- Do not use with damaged cord or plug. If appliance is not working as it should, has been dropped, damaged, left outdoors, or dropped into water, return it to an authorized service center.
- Do not pull or carry by cord, use cord as a handle, close a door on a cord, or pull cord around sharp edges or corners. Do not run appliance over cord. Keep cord away from heated surfaces.
- Do not unplug by pulling on cord. To unplug, grasp the plug, not the cord.
- Do not handle plug or appliance with wet hands.
- Do not put any object into openings. Do not use with any opening blocked; keep free of dust, lint, hair, and anything that may reduce air flow.
- Keep hair, loose clothing, fingers, and all parts of body away from openings and moving parts.
- Do not pick up anything that is burning or smoking, such as cigarettes, matches, or hot ashes.
- Do not use without filter screens in place (Located in dome and in lower tank).
- Turn off all controls before unplugging.
- Use extra care when cleaning on stairs.
- Do not use to pick up flammable or combustible liquids such as gasoline or use in areas where they may be present.

## SAVE THESE INSTRUCTIONS

---

### Contents:

|    |  |    |                                    |
|----|--|----|------------------------------------|
| 2  | Warnings and Precautions               | 12 | Servicing the Vac Motor            |
| 3  | Electrical Information                 | 14 | Vac Shoe Assembly/Brush Adjustment |
| 4  | Equipment Set-up/Controls              | 16 | Tanks/Vac Hoses                    |
| 5  | Operating Instructions                 | 18 | Pump Repair/Manifold/Valve         |
| 6  | Accessory Tool Use/General Information | 20 | Control Panel/Main Handle          |
| 7  | Maintenance                            | 22 | Brush Drive Assembly               |
| 10 | Trouble Shooting                       | 24 | Wiring Diagram                     |
|    |  |    | Warranty                           |

Record the model and serial number on the blue data label located at the rear of the machine .  
These numbers are used when calling upon the Windsor dealer for parts and service.

MODEL \_\_\_\_\_ SERIAL NO. \_\_\_\_\_ PURCHASE DATE \_\_\_\_\_

## Equipment Set-Up:

1. Connect hoses to dome.
2. Loop power cord through strain relief as shown.
3. Become familiar with the machine.

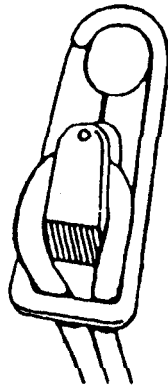

## CONTROLS

Before operating the ADP become familiar with the controls located at the back of the machine and on the control panel.

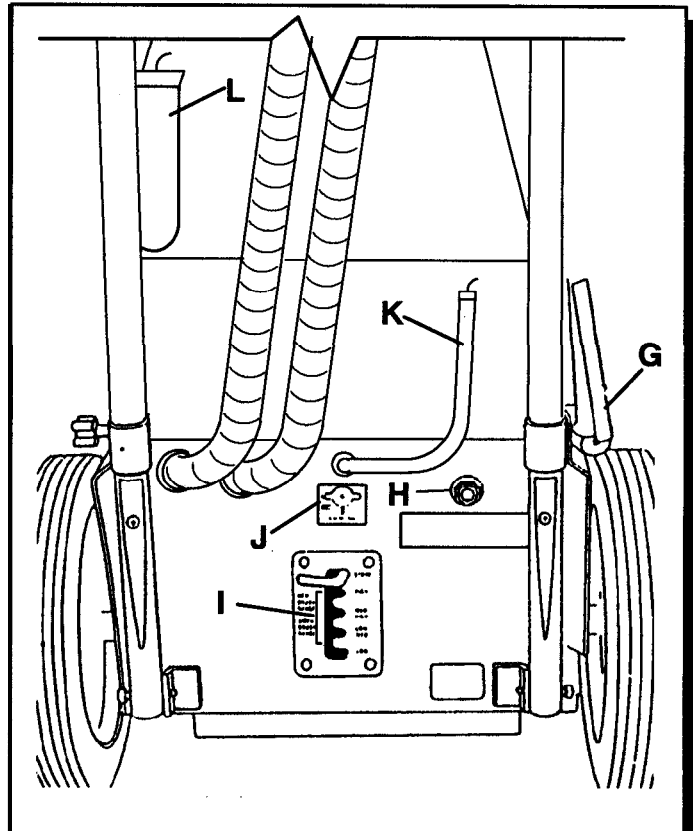
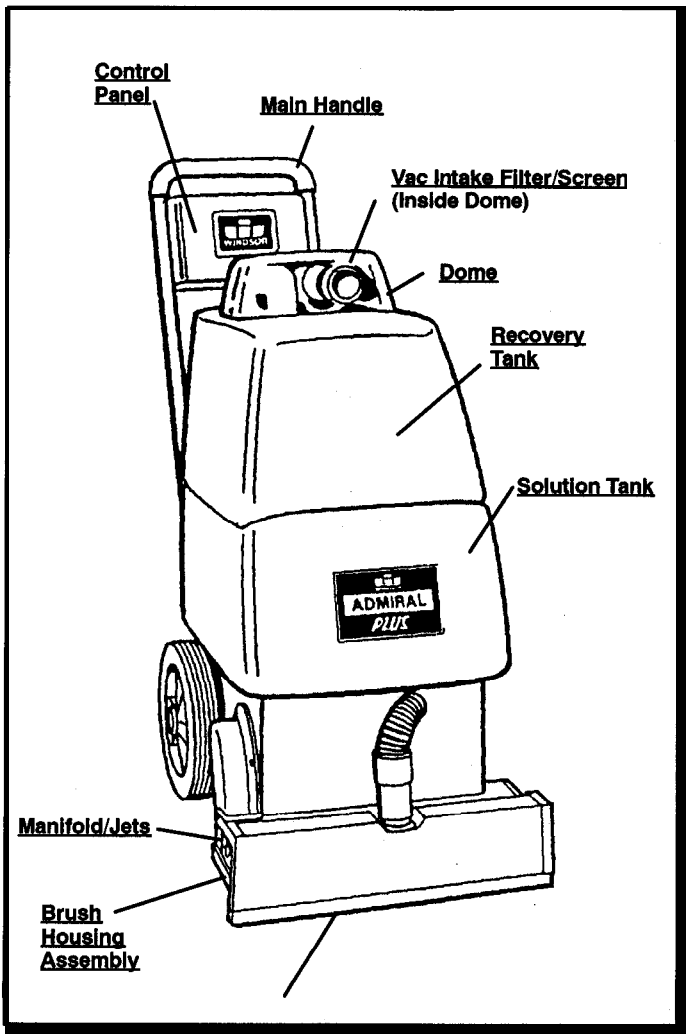
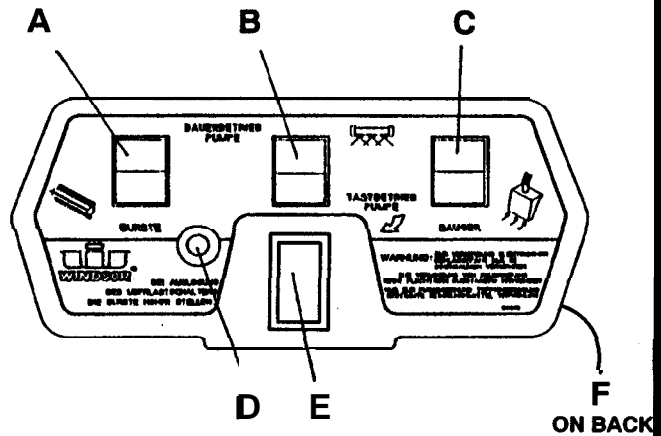

- |                                |                                      |
|--------------------------------|--------------------------------------|
| A Bush Switch                  | G Handle Lock Lever                  |
| B Continuous Pump Switch       | H Accessory Tool Solution Connection |
| C Vacuum Switch                | I Brush Adjustment Lever             |
| D Brush Motor Circuit Breaker  | J Solution Valve                     |
| E Intermittent Pump Switch     | K Solution Drain Hose                |
| F Vacuum Motor Circuit Breaker | L Recovery Drain Hose                |

## IMPORTANT SHIPPING NOTE

Carefully unpack your scrubber and inspect it for shipping damage. Any damages which occurred during shipping are the responsibility of the carrier, who must be notified immediately.

## ELECTRICAL:

In the USA this vacuum operates on a standard 15 amp 115 volt A.C. power circuit (120V nominal). Special voltage models are available for international applications. The amp, hertz, and voltage are listed on the data label found on each machine. Using voltages above or below those indicated on the data label will cause serious damage to the motors,

## EXTENSION CORDS:

If an extension cord is used in the USA, the wire size **must** be the same type and at least one size larger than the power cord on the machine. Do not use over 50 ft. (15m) of extension cord(s). The ADP is equipped with a 50 ft. (15m) 14/3 SJTW/-A power cord. Owner's with International versions of this product need to consult their local electrical authority.

## NOTE:

If connected to a circuit protected by fuses, use time-delay fuses with this product..

## GROUNDING INSTRUCTIONS:

This appliance must be grounded. If it should malfunction or breakdown, grounding provides a path of least resistance for electric current to reduce the risk of electric shock. This appliance is equipped with a cord having an equipment-grounding conductor and grounding plug. The plug must be inserted into an appropriate outlet that is properly installed and grounded in accordance with all local codes and ordinances.

This appliance is for use on a nominal 120-volt circuit, and has a grounded plug that looks like the plug in "Fig. A". A temporary adaptor that looks like the adaptor in "Fig. C" may be used to connect this plug to a 2-pole receptacle as shown in "Fig. B", if a properly grounded outlet is not available. The temporary adaptor should be used only until a properly grounded outlet (Fig. A) can be installed by a qualified electrician. The green colored rigid ear, lug, or the like extending from the adaptor must be connected to a permanent ground such as a properly grounded outlet box cover. Whenever the adaptor is used, it must be held in place by a metal screw.

## WARNING:

Improper connection of the equipment-grounding conductor can result in a risk of electric shock. Check with a qualified electrician or service person if you are in doubt as to whether the outlet is properly grounded. Do not modify the plug provided with the appliance - if it will not fit the outlet, have a proper outlet installed by a qualified electrician.

## INSTRUCTIONS VISANT LA MISE A LA TERRE

Cet appareil doit être mis à la terre. En cas de défaillance ou de panne éventuelles, la mise à la terre fournit au courant un chemin de moindre résistance qui réduit le risque de choc électrique. Cet appareil est pourvu d'un cordon muni d'un conducteur de terre et d'une fiche avec broche de terre. La fiche doit être branchée dans une prise appropriée correctement installée et mise à la terre conformément aux règlements et ordonnances municipaux.

## ADVERTISSEMENT:

Un conducteur de terre mal raccordé peut entraîner un risque de choc électrique. Consulter un électricien ou un technicien d'entretien qualifié si vous n'êtes pas certain que la prise est correctement mise à la terre. Ne pas modifier la fiche fournie avec l'appareil - si elle ne peut être insérée dans la prise, faire installer une prise adéquate par un électricien qualifié.

## PROPER GROUNDING CONNECTION

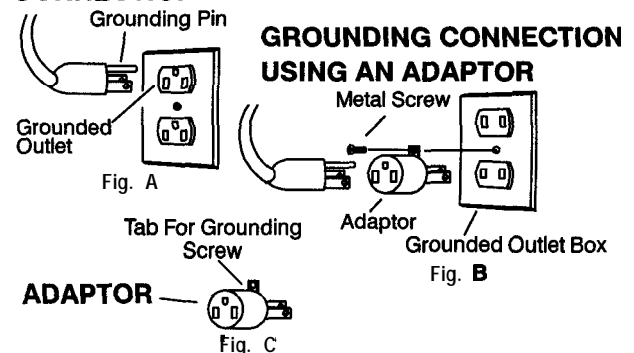

**NOTE:** In Canada, the use of a temporary adaptor is not permitted by the Canadian Electrical Code

**NOTE:** Au Canada, l'utilisation d'un adaptateur temporaire n'est pas autorisée par le Code canadien de l'électricité.

## FILLING THE ADP

1. Remove clear dome from upper tank.  
Do **not** remove the two vacuum hoses.

NOTE: Dome can be set securely between handle uprights when the handle is in operating position.

2. Lift upper recovery tank from machine and set aside.
3. Use a clean bucket to fill solution tank with hot water. Add a non-foaming concentrate for use in hot water extractors at the proportions noted on the container.

**CAUTION:**  
To avoid possible distortion of polyethylene solution/recovery tanks, **DO NOT USE WATER TEMPERATURE THAT EXCEEDS 140° F (60° C).**

Make sure dome is seated correctly to ensure proper vacuum seal.

**CAUTION:**  
Use only the suitable chemicals listed below. Using incompatible chemicals will damage the machine. Damages of this type are not covered under warranty. Carefully read ingredients on manufacturer's label before using any product in this machine.

### SUITABLE CHEMICALS

Alkalis  
Clorox II Bleach\*  
Defoaming Agents  
Detergents  
Hydroxides  
Oxygen Bleaches  
Soaps  
Sta-Puf Fabric Softener\*  
Vinegar  
White Monday Bleach\*

### INCOMPATIBLE CHEMICALS

Aldehydes  
Aromatic Hydrocarbons  
**Butyls**  
Carbon Tetrachloride  
**Clorox\***  
Chlorinated Bleaches  
Chlorinated Hydrocarbons  
**D-Limonene**  
**Lysol\***  
Methyls (MEK)  
Perchloroethylene(perc)  
Phenols  
Trichlorethylene

\* Registered Trademark

## OPERATING THE ADP

1. Vacuum the carpet and make sure it is cleared of surface debris before cleaning with the ADP.
2. Release handle lock lever located on the lower right side of the handle and lower handle to a comfortable operating position. Lock the handle in position.

**NOTE:** The ADP cleans by pulling backwards over the carpet.

3. Adjust brush to proper cleaning position by using the lever located at the lower back of the motor housing. Start at No. 1 "New Brush" (black) position. If more carpet pile agitation is desired, lower brush setting one position at a time.

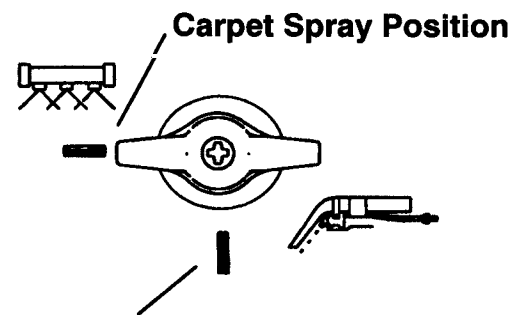
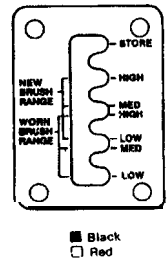

4. Check to be sure spray manifold valve is set at the "Carpet Spray" position and that the brush motor circuit breaker on the control panel is in.
5. Tilt the machine back on rear wheels until brush is off the floor. Turn on the brush and vacuum switches.

### NOTES:

1. Starting the machine with dry brush resting on carpet may trip the brush motor circuit breaker.
2. The vacuum motor is also protected by a circuit breaker. This breaker will only trip under conditions of abuse, such as an overflowing recovery tank.

6. Lower machine to floor. Dispense solution by using either the continuous pump switch or the intermittent pump switch. Use the continuous pump switch for large open areas. Use the intermittent pump switch for small confined areas. Walking backwards, move the extractor over the area to be cleaned. The extractor's brush assistance allows the machine to move quickly and easily over the carpet. Remember to turn off the pump switch about six inches before the end of each pass.
7. As you work check for foam building up in the recovery tank. If foam is building up stop and add the recommended amount of defoaming compound to the recovery tank.

**Never put defoaming compound in the solution tank!**

**WARNING:**

An overflow of foam from the recovery tank into the vacuum intake can damage the vacuum motor. Always be aware of the waste water level in the recovery tank. When the tank is about three quarters full, turn off the machine, bring the machine to a floor drain, and drain the recovery tank using the convenient drain hose located at the rear left corner of the tank.

- a. As the extractor begins to run out of cleaning solution it will start streaking and won't completely clean the carpet. When the extractor runs out of cleaning solution turn off the machine, drain the recovery tank as described above, remove the dome and recovery tank, and refill the clean solution tank.
9. Ventilate the area which has been cleaned. Keep children and pets away and prohibit traffic until carpet is completely dry.

**To Use an Accessory Tool:**

1. Turn the machine completely off and unplug it from electrical outlet.
2. Turn solution valve to "Accessory Tool Position".
3. Remove recovery hose (white cuff) from dome and insert hose from accessory tool in its place.
4. Attach solution hose from accessory tool to the "Accessory Tool Solution Connection" located on the upper right back of the chassis.
5. Make sure the solution tank has solution and that the recovery dome and tank are in place and ready for operation.
6. Plug the machine in and turn on only the vac/pump switch.

**CAUTION:**

**Using accessory tool with brush switch on may damage floor**

7. Make sure the solution valve is returned to the "Carpet Spray Position" before returning the ADP to standard carpet extraction.
6. Turn off the machine and unplug it from electrical outlet before disconnecting accessory tool.

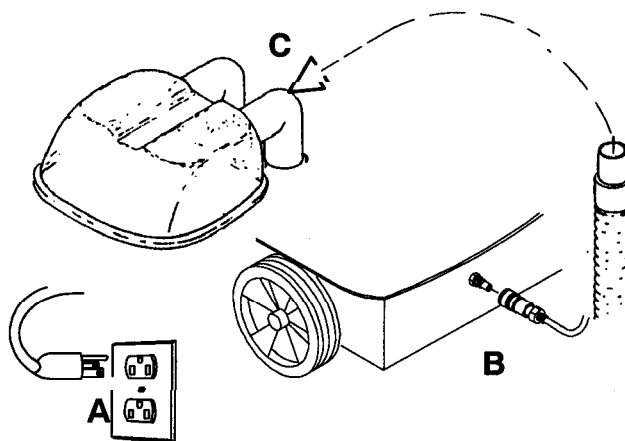

**Approved Accessory Tools:**

- Standard Floor Wands (SFW, SW, or SW-PRO)
- Deluxe Hand Tool (DHT)
- Upholstery Hand Tool (UPH3)

## **ADP MAINTENANCE INSTRUCTIONS**

**WARNING:** Remove the machine power cord from the electrical source before making any adjustments or repairs. **ONLY QUALIFIED MAINTENANCE PERSONNEL ARE TO PERFORM REPAIRS.**

### **HANDLE LOCK ADJUSTMENT**

The black knob on the opposite end of the rod from the adjusting lever controls the tightness of the adjusting knob.

### **VAC SHOE**

Remove the screws holding the parallel arms to take off the vac shoe for repairs or replacement.

When reinstalling the vac shoe be sure that the wave washers are floating and not pinched.

### **BRUSH ASSEMBLY AND BEARINGS**

1. Remove belt guard and roll belt off motor pulley.
2. Tilt machine back on handle and remove brush pulley guard.
3. Remove shaft retaining screws and washers from each end of the brush shaft.
4. Replace brush or bearings as required.

### **TRANSPORT WHEELS**

Remove screw and hub cap to service wheel.

Before putting wheel back on clean axle and apply a light coat of silicon lubricant.

### **SUPPORT ROLLER**

1. Tilt machine back on handle.
2. Loosen lock nuts on each end of roller axle and remove assembly.
3. Replace and repair as necessary.
4. Clean axle and apply a light coat of silicon lubricant before reassembling.

### **SWITCH CONTROL PANEL**

The switches and circuit breakers are accessed through the panel located on the bottom of the control panel.

### **CAUTION:**

After making repairs use the wiring diagram located on the access panel or in this manual to be sure all wire leads are properly connected.

### **ACCESSING THE CHASSIS**

1. Drain both tanks completely.
2. Remove dome and recovery tank.
3. Tilt machine back on handle and remove (4) nuts holding solution tank to chassis.
4. Return machine to upright position.
5. Raise tank and remove hose from pump inlet and set solution tank aside.

### **PUMP**

1. Access chassis as described above.
2. Disconnect wire leads.
3. Remove (4) screws attaching pump to chassis.
4. Disconnect hoses and remove pump.

Refer to the pump assembly drawing for internal parts and repairs.

**CAUTION:** Do not over-tighten the hose-barbs on the pump head. Over-tightening the hose-barbs can cause the pump head to crack and begin leaking.

**WARNING:** The internal solution hoses are encased in an outer hose to protect the electrical component parts in the unlikely event a solution hose should rupture. Replace hoses exactly as originally supplied.

## POTENTIAL INJURY:

### Warning:

This product contains moving parts.

To reduce the risk of injury - unplug the machine before servicing.

Maintenance and repairs must be done by qualified personnel ONLY.

### CAUTION:

Using non-Windsor parts to repair this machine will void the 6-3-1 warranty.

### Suggested Service Parts List

| DESCRIPTION                           | PART NUMBER  |
|---------------------------------------|--------------|
| <u>Belt</u>                           | <u>11015</u> |
| <u>Brush Bearinas</u>                 | <u>09019</u> |
| <u>115V Cord Assemblv (USA/Japan)</u> | <u>23086</u> |
| <u>115V Cord End (USA)</u>            | <u>26009</u> |
| <u>Dome Assembly</u>                  | <u>28033</u> |
| <u>Dome Gasket</u>                    | <u>35060</u> |
| <u>Hose Cuff, Blue</u>                | <u>27354</u> |
| <u>Hose Cuff, White</u>               | <u>27079</u> |
| <u>Jet Assembly</u>                   | <u>44055</u> |
| <u>Jet</u>                            | <u>44061</u> |
| <u>Jet Seal</u>                       | <u>44051</u> |
| <u>Jet Body w/Seal</u>                | <u>44052</u> |
| <u>Manifold Assembly</u>              | <u>54095</u> |
| <u>Screen/Filter, Dome</u>            | <u>34140</u> |
| <u>Screen/Filter, Solution Tank</u>   | <u>73772</u> |

### DAILY MAINTENANCE:

These procedures are followed at the end of each work period to extend the life of the machine.

- 1.) Empty unused cleaning solution by disconnecting clear hose on back of machine and pouring into floor drain.
  - 2.) Inspect and clean solution filter screen inside tank and vac intake screen inside dome.
  - 3.) Flush the system. Fill solution tank with 1 or 2 gallons (4 - 8 liters) of clean ot water. With machine over floor drain turn on vac/pump switch until solution tank is empty.
  - 4.) Inspect spray pattern of jets. Remove jets and rinse if clogged.
  - 5.) After each use, rinse tank with fresh water. Periodically inspect the recovery tank and decontaminate if necessary, using a Hospital Grade Virucide or a I-1 0 bleach to water solution. Waste water should be disposed of properly.
  - 6.) Remove any lint or debris from brush.
  - 7.) Inspect power cord. Remember, this cord will lay on damp carpet.
- Warning: IMMEDIATELY REPLACE WORN OR FRAYED POWER CORDS.**
- 8.) Inspect hoses. Worn or cracked hoses may cause loss of vac pressure.
  - 9.) Place the brush in the storage position. Press back slightly on the main handle, press down on the control knob and turn until the pin drops into the slot; rotate another 90" to lock.

**For infrequent use or long periods of storage,** flush the system with a neutralizing solution of 1 quart (1 liter) white vinegar mixed with 2 gallons (8 liters) hot water. Flush the system with clean hot water after neutralizing.

## **PERIODIC MAINTENANCE:**

These procedures are performed by a trained service technician. The regularity of these procedures may depend on the machine's use.

- 1.) Flush the system with a special solution to reduce scaling (alkaline build-up).  
  
Use acetic acid (white vinegar) or an anti-browning solution. Mix one quart acetic acid with 2 gallons (1:8 liters) of hot water in the solution tank (if an anti-browning solution is used follow manufacturer's instructions). Turn on the vac/pump switch and allow the machine to run over a floor drain until the solution tank is empty (approximately once a month).
- 2.) Inspect hoses and cords, replace as needed.
- 3.) Inspect filter screens, clean or replace as needed.
- 4.) Inspect spray pattern of jets, replace or clean as needed.
- 5.) Check the tension of the solution valve cable, tighten if necessary.
- 6.) Inspect the vac motor, remove any lint build-up at cooling intake, service carbon vac motor brushes (Approximately every 750 operation hours).
- 7.) With the machine running, the brush should rotate freely without rattling or grinding. Replace bearings if necessary.

## **CAUTION:**

Do not allow this machine to remain in a vehicle or area where the temperature will be below 40°F (4°C). Allowing this machine to freeze will cause damage not covered by the 6-3-i warranty.

## **CAUTION:**

Protect this machine from freezing if it becomes necessary to store it at temperatures below 40°F (4°C).

Use a methyl hydrate window washer type anti-freeze; mix a gallon or two (4-8 liters) of anti-freeze solution, following the manufacturer's instructions. Add the anti-freeze solution to the solution tank. With the hoses in place run the machine until the anti-freeze begins spraying out (don't empty solution tank). Vacuum out the remaining anti-freeze solution in the solution tank. Disconnect the hoses and empty the recovery bucket. Always allow the unit to return to room temperature before filling with hot water or operating.

## **CAUTION:**

Do not use Ethylene Glycol or any cooling system anti-freezes.

# TROUBLESHOOTING CHART

| Condition   | Corrective Action  |
|---|--|
| <b><u>No Power To Machine:</u></b>                        |  |
| Dead electrical circuit breaker in fuse box               | Check building circuit breaker.  |
| Faulty power cord   | Replace  |
| Power switch failure                                      | Test switch for continuity/Replace if necessary.   |
| Faulty circuit breaker                                    | Test circuit breaker for continuity/Replace if necessary.  |
| Internal wiring problem                                   | With the machine unplugged, check for, and correct, any loose wire connections inside the machine at the switches and terminal block.  |
| <b><u>Electrical Shock:</u></b>                           |  |
| Equipment not grounding                                   | Follow grounding instructions exactly.   |
| Receptacle not grounded                                   | Have an electrician inspect the building's wiring.   |
| Internal electrical problem                               | Ensure that the machine's wiring matches the appropriate wiring diagram. Check for and correct any loose wire connections. Replace any wires or components which are short circuiting.                   |
| <b><u>Nuisance Tripping of Circuit Breaker:</u></b>       |  |
| Brush "buried" in carpet<br>(More than <b>3/8"</b> (1 cm) | Brush is adjusted too low, adjust position using the adjustment control at the front of machine. Best cleaning results are achieved with a minimal brush/carpet contact of less than <b>3/8"</b> (1 cm). |
| Dry brush   | Turn brush motor and pump switches on with machine tilted rearward (brush off floor). Lower machine back to carpet slowly.   |
| Faulty circuit breaker                                    | Test circuit breaker for continuity/Replace if necessary.  |
| Mechanical problem  | Higher amp draws may indicate a mechanical problem. Find parts which are not moving freely and repair or replace.  |
| <b><u>Vacuum Motor Speed Varies or Doesn't Run:</u></b>   |  |
| Worn motor brushes  | Replace  |
| Motor worn out  | Replace  |
| Faulty switch   | Replace  |
| Faulty circuit breaker                                    | Replace  |
| Internal wiring problem                                   | Check for and correct any loose wire connections,  |
| <b><u>Loss Of Vacuum:</u></b>                             |  |
| Loose vac dome  | Center dome over tank.   |
| Crack in dome or poor joint                               | Replace or repair using acrylic plastic cement only.   |
| Loose cuffs on vacuum hose                                | Tighten cuffs (turn counter clockwise).  |
| Damaged Dome Gasket                                       | Replace gasket.  |
| Lint or dirt clogging vacuum intake screen                | With power off clean vac intake screen found in dome.  |
| Accessory tool clogged                                    | Clean out tool, ensure free airflow.   |
| Vac hose damaged  | Replace  |
| Internal electrical problem                               | Have a trained service technician inspect and repair the machine.  |

## TROUBLESHOOTING CHART

| Condition  | Corrective Action   |
|--|---|
| <b><u>Accessory Tool Fitting Difficult to Connect:</u></b> |   |
| Corrosion on fitting                                       | Clean with steel wool.<br><br>Remove and soak in acetic acid (white vinegar).<br><br>Lubricate lightly with silicone base lubricant.      |
| <b><u>Carpet Not Getting Clean:</u></b>                    |   |
| Severe soil conditions                                     | Make several passes at right angles to each other.<br><br>Use a prespray.   |
| <b><u>Carpet Too Wet:</u></b>                              |   |
| Worn spray jet(s)  | Replace spray jets which are producing more than a fine mist.   |
| <b><u>Carpet Not Getting Wet:</u></b>                      |   |
| Solution filter screen clogged                             | Clean solution filter screen located inside lower tank near the front.  |
| Spray jet(s) clogged                                       | Clean or replace jets.<br><br><b>Do not use a wire to clean jet.</b><br><br>Damaged jets will cause over-saturation.                      |
| Pump not running   | Check for and correct any loose wires   |
| Faulty pump  | Repair or replace   |
| Solution valve adjustment                                  | Adjust solution valve cable until valve operates when handle is pulled.   |
| <b><u>Brush Not Turning:</u></b>                           |   |
| Belt broken  | Remove belt cover on right side of machine. Inspect belt.<br>Replace if necessary.  |
| Faulty switch  | Replace.  |
| Faulty circuit breaker                                     | Replace.  |
| Faulty brush motor   | If the belt, circuit breaker, and switch have been tested and found to be in good working order, the brush motor may need to be replaced. |
| <b><u>Worn Bearings:</u></b>                               |   |
| Squealing or grinding sound in brush housing               | Replace bearings.   |

# SERVICING THE VAC MOTOR

**Carbon Brushes**  
14445 115V  
14680 100V

**WARNING:** The green ground wire must attach the motor to the power cord for safe operation. See wiring diagram.

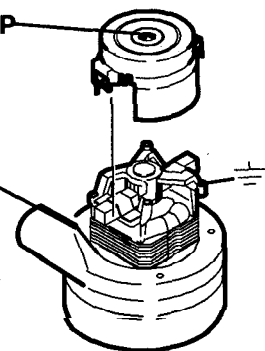

***Note:** When replacing carbon vac motor brushes loosen wire terminal **BEFORE** removing screws on bracket*

If armature commutator is not concentric, extremely pitted, or grooved the motor will need to be replaced or sent to a qualified service center to restore vac performance.

### Wire Terminal

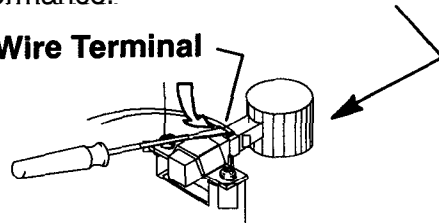

### Important:

These brushes wear quicker as the length shortens due to increased heat.

**Spring inside brush housing will damage motor if brushes are allowed to wear away completely.**

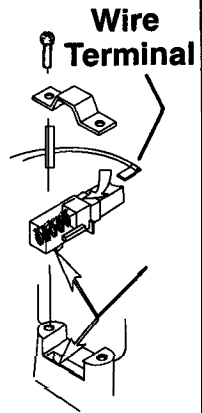

### Note:

Place stop in groove.

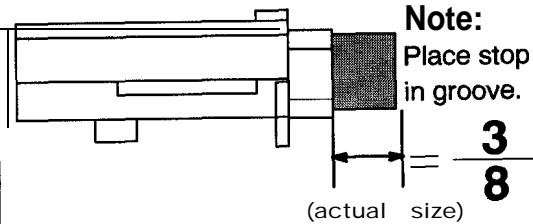

Periodically check the length of the carbon brushes. Replace both carbon brushes when either is less than 3/8" long.

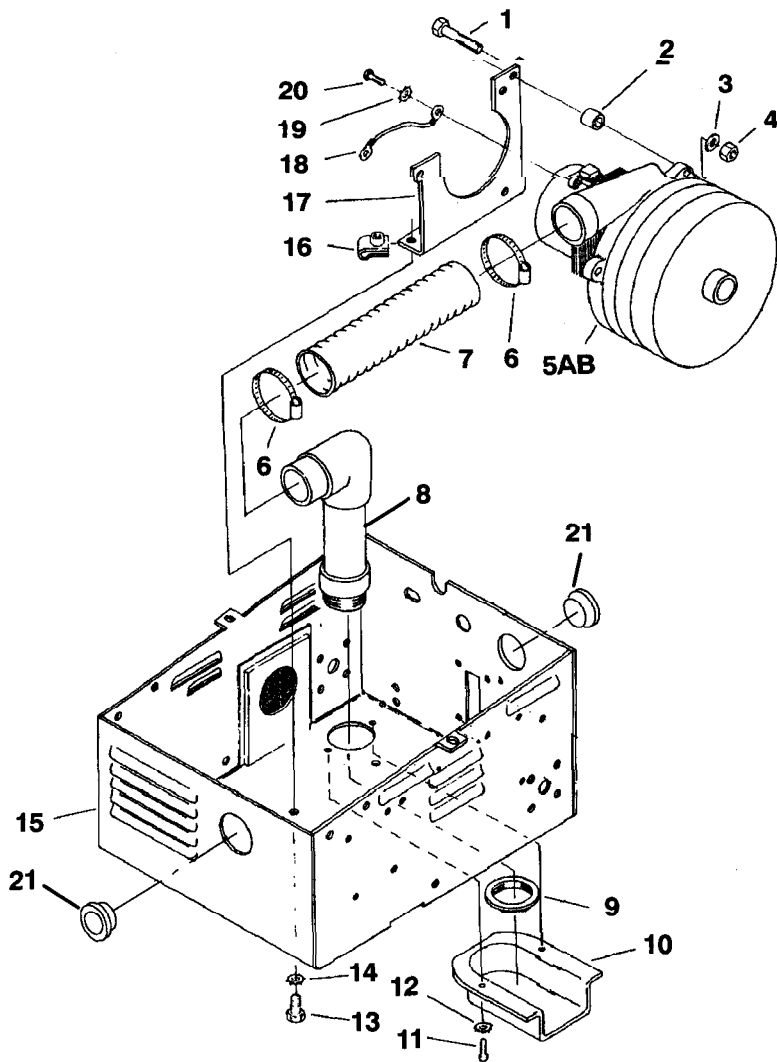

## VAC MOTOR ASM Parts List

| Ref | Qty. | Part No. | Description                    | Serial No. |    | Notes: |
|-----|------|----------|--------------------------------|------------|----|--------|
|     |      |          |                                | From       | To |        |
| 1   |      | 70249    | Scr, 1/4-20 x 1.25 HHCS pltd.  |            |    |        |
| 2   |      | 73215    | Spacer, 3/8 OD x 1/4           |            |    |        |
| 3   |      | 87013    | Washer, 1/4 Flat               |            |    |        |
| 4   |      | 57047    | Nut, 1/4-20 Nylock             |            |    |        |
| 5A  |      | 53134    | Vac Motor, 11 5V 3 Stage TD TB |            |    |        |
| 5B  |      | 53183    | Vac Motor, IOOV3AStageTDTB     |            |    |        |
| 6   |      | 20046    | Clamp, 2.25 Worm Gear          |            |    |        |
| 7   |      | 39231    | Hose, UL Vac Exhaust x 12      |            |    |        |
| 8   |      | 54070    | Muffler Asm. ADM Vac exhaust   |            |    |        |
| 9   |      | 57039    | Nut, 1.5 NPT flange            |            |    |        |
| 10  |      | 29135    | Deflector, ADM-UL Vac exhaust  |            |    |        |
| 11  |      | 70363    | Scr, 10-32 x 3/8 PHTR          |            |    |        |
| 12  |      | 87018    | Washer, #10 Star               |            |    |        |
| 13  |      | 70011    | Scr, 1/4-20 x 5/8 HHCS         |            |    |        |
| 14  |      | 87025    | Washer, 1/4 flat               |            |    |        |
| 15  |      | 34228    | Frame, ADP Main                |            |    |        |
| 16  |      | 57082    | Nut, 1/4-20 Captive J          |            |    |        |
| 17  |      | 14242    | Brkt, ADM Vac Motor            |            |    |        |
| 18  |      | 88345    | Wire. Ground                   |            |    |        |
| 19  |      | 87016    | Washer, #10 Star               |            |    |        |
| 20  |      | 70191    | Scr, 10-32 x 1/2 HHTC          |            |    |        |
| 21  |      | 14042    | Bushing, 1.63 ID snap UL/CSA   |            |    |        |

# VAC SHOE ASSEMBLY AND BRUSH PRESSURE MECHANISM

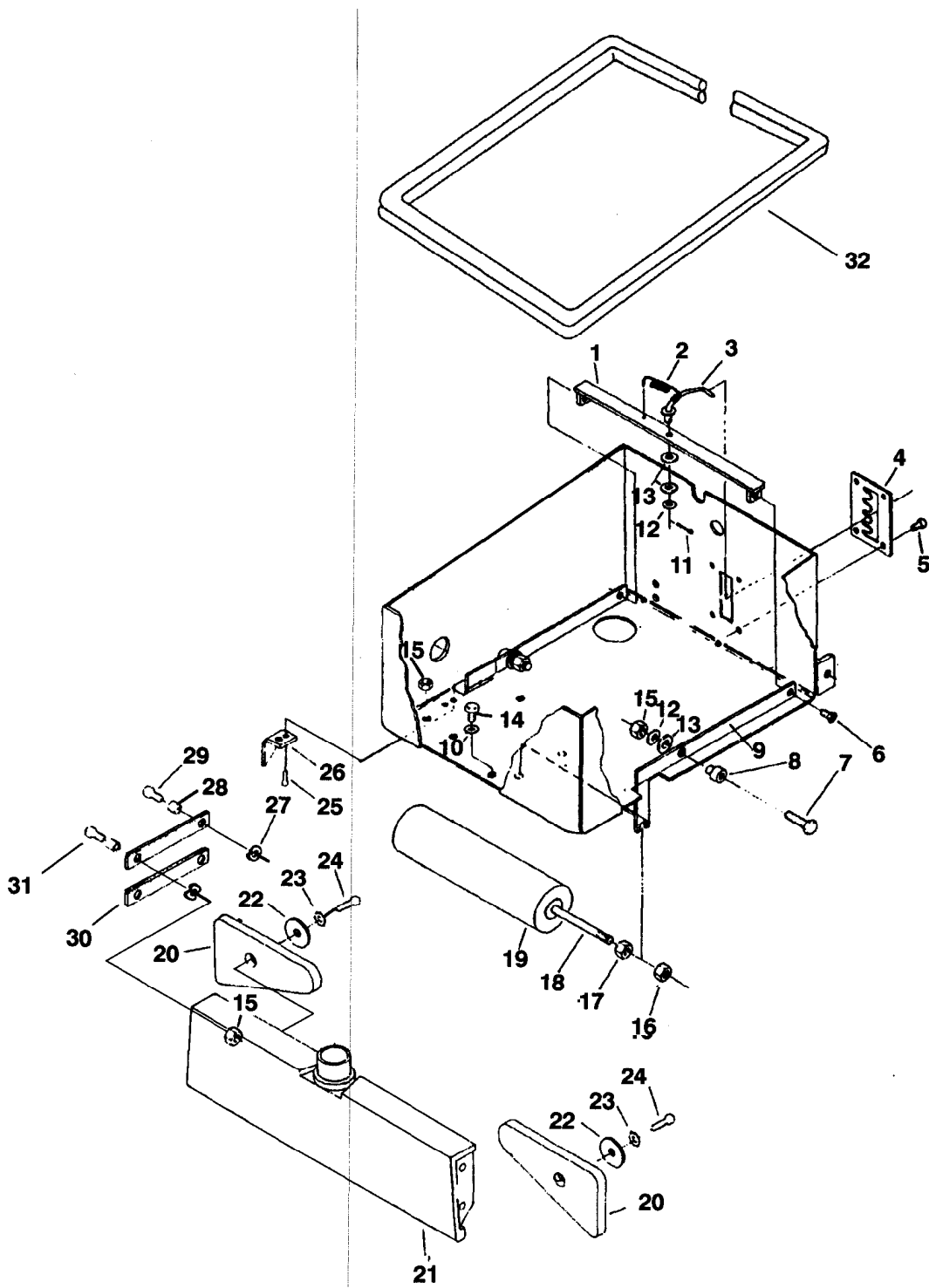



# VAC SHOE ASSEMBLY & BRUSH PRESSURE MECHANISM Parts List

| Ref | Part No. | Qty | Description                   | Serial No. |    | Notes: |
|-----|----------|-----|-------------------------------|------------|----|--------|
|     |          |     |                               | From       | To |        |
| 1   | 14246    |     | Brkt, Roller Adj.             |            |    |        |
| 2   | 73040    |     | Spring, #55 Music Wire        |            |    |        |
| 3   | 51247    |     | Lever Asm, Roller Adjustment  |            |    |        |
| 4   | 62115    |     | Plate, Height Adj.            |            |    |        |
| 5   | 70363    |     | Scr, 10-32 x 3/8 PHTR         |            |    |        |
| 6   | 70166    |     | Scr, 1/4-20 x 1/2 FHMS        |            |    |        |
| 7   | 70018    |     | Scr, 1/4-20 x 1.0 HHCS        |            |    |        |
| 8   | 73178    |     | Spacer, Roller Bracket        |            |    |        |
| 9   | 14244    |     | Brkt, Roller Mounting         |            |    |        |
| 10  | 87025    |     | Washer, 1/4 Star              |            |    |        |
| 11  | 66073    |     | Pin, 1/16 x 3/4 Cotter        |            |    |        |
| 12  | 87013    |     | Washer, 1/4 ID x 5/8 OD       |            |    |        |
| 13  | 87030    |     | Washer, 3/8 ID x 3/4 OD Nylon |            |    |        |
| 14  | 70020    |     | Scr, 1/4-20 x 1/2 HHCS        |            |    |        |
| 15  | 57047    |     | Nut, 1/4-20 Lock              |            |    |        |
| 16  | 57085    |     | 3/8-16 Lock Hex Jam           |            |    |        |
| 17  | 57022    |     | Nut, 3/8-16 Lock              |            |    |        |
| 18  | 03027    |     | Axle, Roller                  |            |    |        |
| 19  | 67082    |     | Roller, ADM x 10.88"          |            |    |        |
| 20  | 89061    |     | Weight, Adm Vac Shoe          |            |    |        |
| 21  | 85028    |     | Vac Shoe                      |            |    |        |
| 22  | 87008    |     | Washer, 1/4 ID x 1.25         |            |    |        |
| 23  | 87016    |     | Washer, #10 Star              |            |    |        |
| 24  | 70088    |     | Scr, 10-32 x 1/2 PHMS         |            |    |        |
| 25  | 67005    |     | Rivet, 1/8 OD WI-IT AL        |            |    |        |
| 26  | 36050    |     | Gusset, Belt Guard            |            |    |        |
| 27  | 87074    |     | Washer, 3/8 ID x .010 Wave    |            |    |        |
| 28  | 73181    |     | Spacer, .259 ID x 3/8 x 1/4   |            |    |        |
| 29  | 70190    |     | Scr, 1/4-20 x 1/2 BHCS        |            |    |        |
| 30  | 05016    |     | Arm, Vac Shoe Parallel        |            |    |        |
| 31  | 70057    |     | Scr, 1/4-20 X 1 PPHMS         |            |    |        |
| 32  | 35233    |     | Gasket, FB9 Frame Top         |            |    |        |

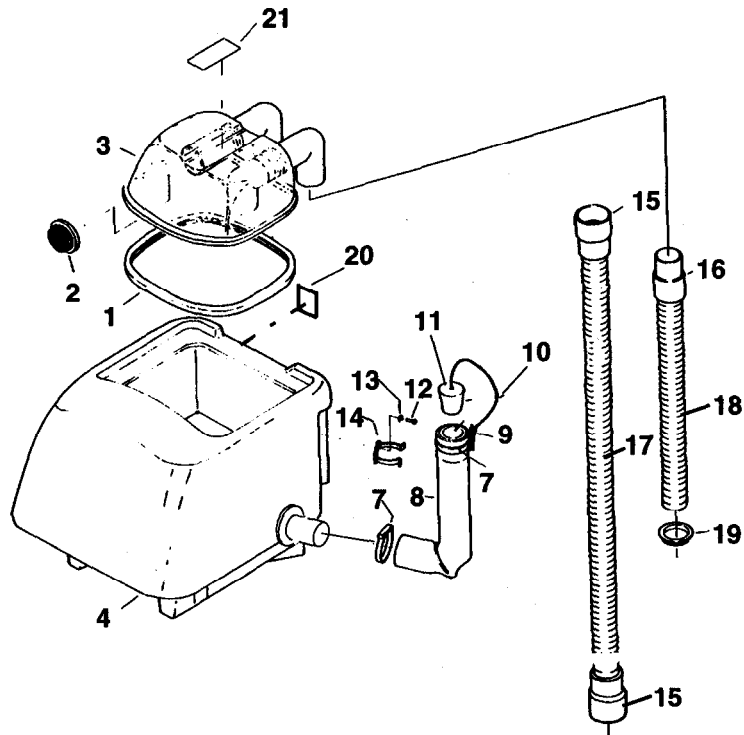

*NOTE: Each tank has a filter screen which protects the machine's internal parts from damage. Ensure that these screens are in place and clean before operating the machine.*

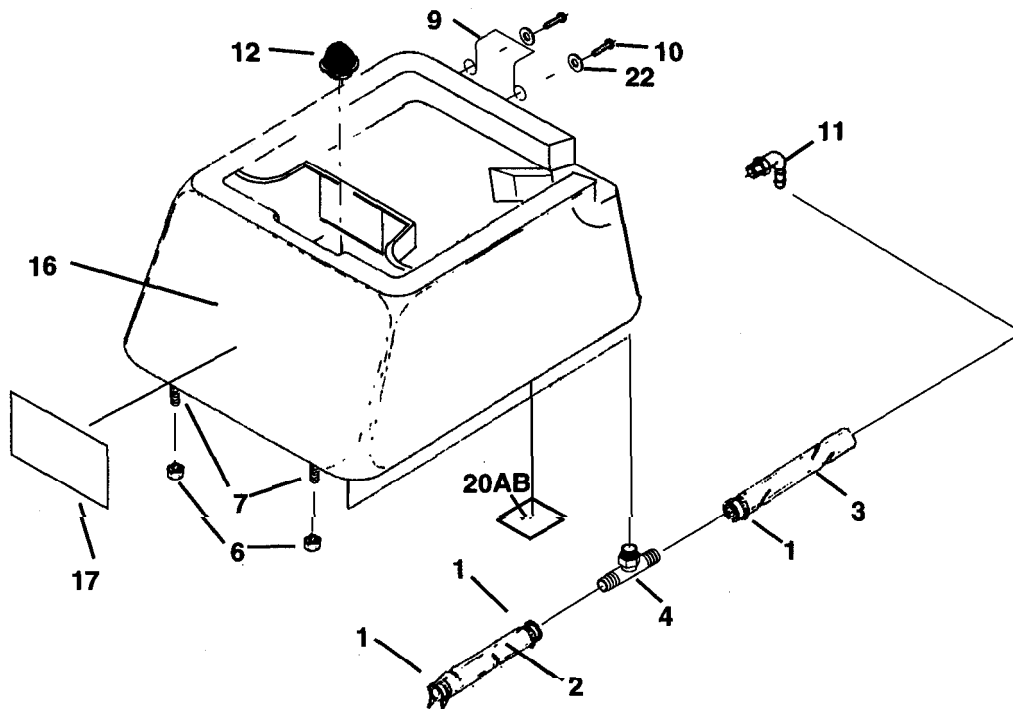



# TANKS AND VAC HOSE ASSEMBLY Parts List

## RECOVERY TANK PARTS LIST:

| Ref | Part No. | Qty | Description                    | Serial No. |    | Notes: |
|-----|----------|-----|--------------------------------|------------|----|--------|
|     |          |     |                                | From       | To |        |
| 1   | 35060    |     | Gasket, Dome                   |            |    |        |
| 2   | 34140    |     | Filter, Vac Intake 10 Mesh     |            |    |        |
| 3   | 28025    |     | Dome                           |            |    |        |
| 4   | 75204    |     | Tank, Recovery ADP II          |            |    |        |
| 5   | -        |     | OPEN                           |            |    |        |
| 6   | -        |     | OPEN                           |            |    |        |
| 7   | 20002    |     | Clamp, 2" Nylon Ratchet        |            |    |        |
| 8   | 39353    |     | Hose, 1.5 x 12" Drain          |            |    |        |
| 9   | 40019    |     | Hosebarb, 1.5 Double mchd      |            |    |        |
| 10  | 27188    |     | Cord, Drain Plug               |            |    |        |
| 11  | 66152    |     | Plug                           |            |    |        |
| 12  | 70052    |     | Scr, 8-32 x 3/8 PHMS           |            |    |        |
| 13  | 87017    |     | Washer, #8 Flat                |            |    |        |
| 14  | 14520    |     | Brkt., Drain hose              |            |    |        |
| 15  | 27354    |     | Cuff, Blue S/C Vac Hose        |            |    |        |
| 16  | 27079    |     | Cuff, 1.5 White Hose           |            |    |        |
| 17  | 39411    |     | Hose, 1.5 x 52" Vac            |            |    |        |
| 18  | 39343    |     | Hose, 1.5 x 34" Vac            |            |    |        |
| 19  | 14042    |     | Bushing, 1.63 Snap             |            |    |        |
| 20  | 50776    |     | Label, For Safety              |            |    |        |
| 21  | 50775    |     | Label, Explosion Warning vert. |            |    |        |

## SOLUTION TANK PARTS LIST:

| Ref | Part No. | Qty | Description                    | Serial No. |    | Notes: |
|-----|----------|-----|--------------------------------|------------|----|--------|
|     |          |     |                                | From       | To |        |
| 1   | 20042    |     | Clamp, Hose                    |            |    |        |
| 2   | 39241    |     | Hose, 1/2" Wirebound X 10"     |            |    |        |
| 3   | 39234    |     | Hose, Drain w/sol'n Level -ADP |            |    |        |
| 4   | 40068    |     | Hosebarb, 3/8 NPT x 1/2 Tee    | 409197     |    |        |
| 5   | -        |     | Open                           |            |    |        |
| 6   | 57105    |     | Nut, 1/4-20 w/Star Washer      |            |    |        |
| 7   | 70251    |     | Set Scr, 1/4-20 x 1.0          |            |    |        |
| 8   | -        |     | Open                           |            |    |        |
| 9   | 14630    |     | Retainer, Hose                 |            |    |        |
| 10  | 70020    |     | Screw, 1/4-20 x 1/2 HHCS       |            |    |        |
| 11  | 40027    |     | Hosebarb, 90° 3/8 MPT x 1/2    |            |    |        |
| 12  | 73864    |     | Strainer, 3/8 NPT 60 Mesh      | 409197     |    |        |
| 13  | -        |     | Open                           |            |    |        |
| 14  | -        |     | Open                           |            |    |        |
| 15  | -        |     | Open                           |            |    |        |
| 16  | 75251    |     | Tank, ADP Solution II          |            |    |        |
| 17  | 50622    |     | Label, Main                    |            |    |        |
| 18  | -        |     | Open                           |            |    |        |
| 19  | -        |     | Open                           |            |    |        |
| 20A | 50534    |     | Label, 115V Wiring             |            |    |        |
| 20B | 50503    |     | Label, ADM UL Wiring           |            |    |        |
| 21  | -        |     | Open                           |            |    |        |
| 22  | 87013    |     | Washer, 1/4 ID x 5/8 OD ss     |            |    |        |

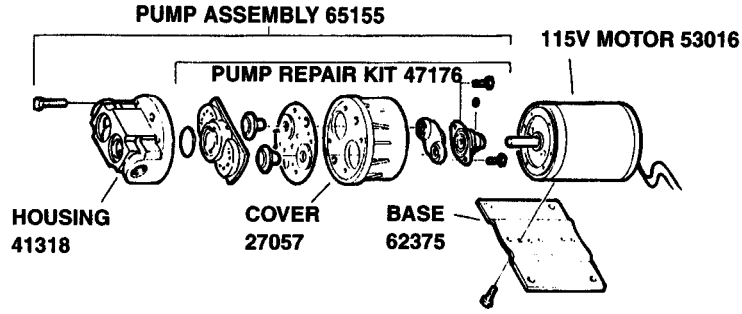

**Spray Jets**

The ADP is equipped with quick change jet nozzles which are easy to clean or replace.

- 1.) With tanks empty, tilt machine back.
- 2.) Press in and turn nozzle 90° to remove.
- 3.) When putting nozzles back into manifold ensure slot in tip runs parallel to manifold.

**Replace jets that no longer produce a fine mist spray or over saturate carpet.**

Rinse in hot water or use compressed air to clean. Nozzles can also be soaked in an acetic acid solution (white vinegar).

**CAUTION: Do not use pins or wires to clean or unclog jets. Using wires or pins may ruin spray pattern.**

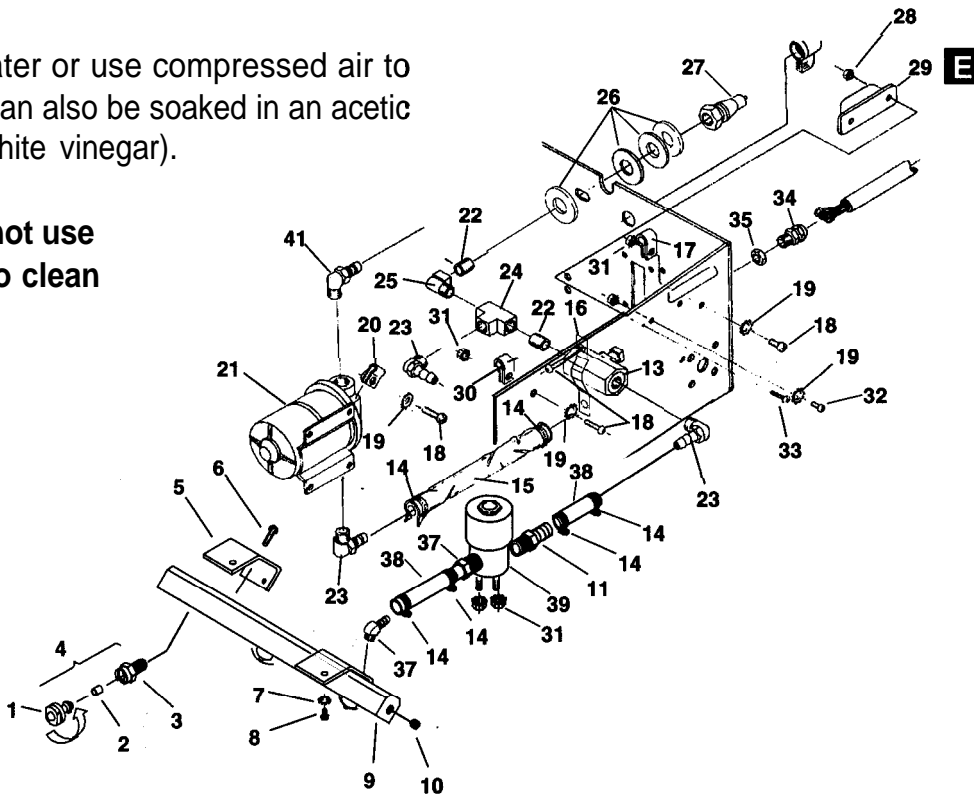



## PUMP REPAIR, MANIFOLD, & VALVE Parts List

| Ref | Part No.     | Qty | Description                              | Serial No. |    | Notes: |
|-----|--------------|-----|--|------------|----|--------|
|     |              |     |  | From       | To |        |
| 1   | 44061        |     | Jet, 11003 Mini-Quick                    |            |    |        |
| 2   | 44051        |     | Jet Seal, Mini-Quick                     |            |    |        |
| 3   | 44052        |     | Jet Body w/ Seal, Mini-Quick             |            |    |        |
| 4   | 44055        |     | Jet Assembly, 11003 Mini-Quick           |            |    |        |
| 5   | 14523        |     | <b>Brkt</b> , Manifold                   |            |    |        |
| 6   | 70114        |     | Scr, #10 x 3/4 Polyfast                  |            |    |        |
| 7   | 87025        |     | washer, 1/4 star                         |            |    |        |
| 8   | <b>70085</b> |     | scr, 1/4-20 x 1/2 PHMS                   |            |    |        |
| 9   | 54094        |     | Manifold ADM                             |            |    |        |
| 10  | 66095        |     | Plug, 1/8 MPT                            |            |    |        |
| 11  | 40014        |     | Hosebarb, 1/4 MPT X 3/8                  |            |    |        |
| 12  |              |     | OPEN                                     |            |    |        |
| 13  | 84065        |     | Valve, 1/4 FPT Ball                      |            |    |        |
| 14  | 20042        |     | Clamp, 3/8 Hose                          |            |    |        |
| 15  | 39311        |     | Hose, 3/8 Rubber x 14"                   |            |    |        |
| 16  | 14454        |     | Bracket, valve <b>retainer</b>           |            |    |        |
| 17  | 20035        |     | Clamp, 7/16 Dia. Nylon                   |            |    |        |
| 18  | 70088        |     | <b>Scr</b> , 10-32 x 1/2 PHMS            |            |    |        |
| 19  | 87016        |     | Washer, #10 Star                         |            |    |        |
| 20  | 57081        |     | Nut, 1-32 Captive J                      |            |    |        |
| 21  | 65154        |     | Pump, <b>115V (ADP)</b>                  |            |    |        |
| 22  | 56014        |     | Nipple, 1/4 Close                        |            |    |        |
| 23  | 40033        |     | Hosebarb, 1/4 MPT x 3/8 90D              |            |    |        |
| 24  | 78156        |     | Tee, 1/4 FPT                             |            |    |        |
| 25  | 31016        |     | <b>Elbow</b> , 1/4 NPT street            |            |    |        |
| 26  | 87015        |     | Washer, 9/16 Flat                        |            |    |        |
| 27  | 56012        |     | Nipple, 1/4 FPT QD                       |            |    |        |
| 28  | 57116        |     | Nut, 632 w/ Star Washer                  |            |    |        |
| 29  | 14020        |     | Terminal Block, <b>115V (343)</b>        |            |    |        |
| 30  | <b>20015</b> |     | Clamp, 9/16 Dia Nylon                    |            |    |        |
| 31  | <b>57104</b> |     | Nut, 1-32 w/Star Washer                  |            |    |        |
| 32  | 70066        |     | Scr, 1-32 x 3/4 PHMS                     |            |    |        |
| 33  | 70210        |     | <b>Scr</b> , 6-32 x 3/4 Blk Nylon        |            |    |        |
| 34  | 73201        |     | <b>Strain</b> Relief, .546 Liq. Tite     |            |    |        |
| 35  | 57107        |     | Nut, Swain Relief <b>M18,6</b>           |            |    |        |
| 36  |              |     | OPEN                                     |            |    |        |
| 37  | <b>40038</b> |     | Hosebarb, 1/4 MPT x 3/8 45 Deg           |            |    |        |
| 38  | 39279        |     | Hose, 3/8 Rubber x 6.26" ( <b>115V</b> ) |            |    |        |
| 39  | 84098        |     | Valve <b>Asm</b> , 115V Sol enoid        |            |    |        |
| 40  |              |     | OPEN                                     |            |    |        |
| 41  | 40042        |     | Hosebarb, 1/4MPT x 1/2H 90 Deg           |            |    |        |

# CONTROL PANEL / MAIN HANDLE ASSEMBLY

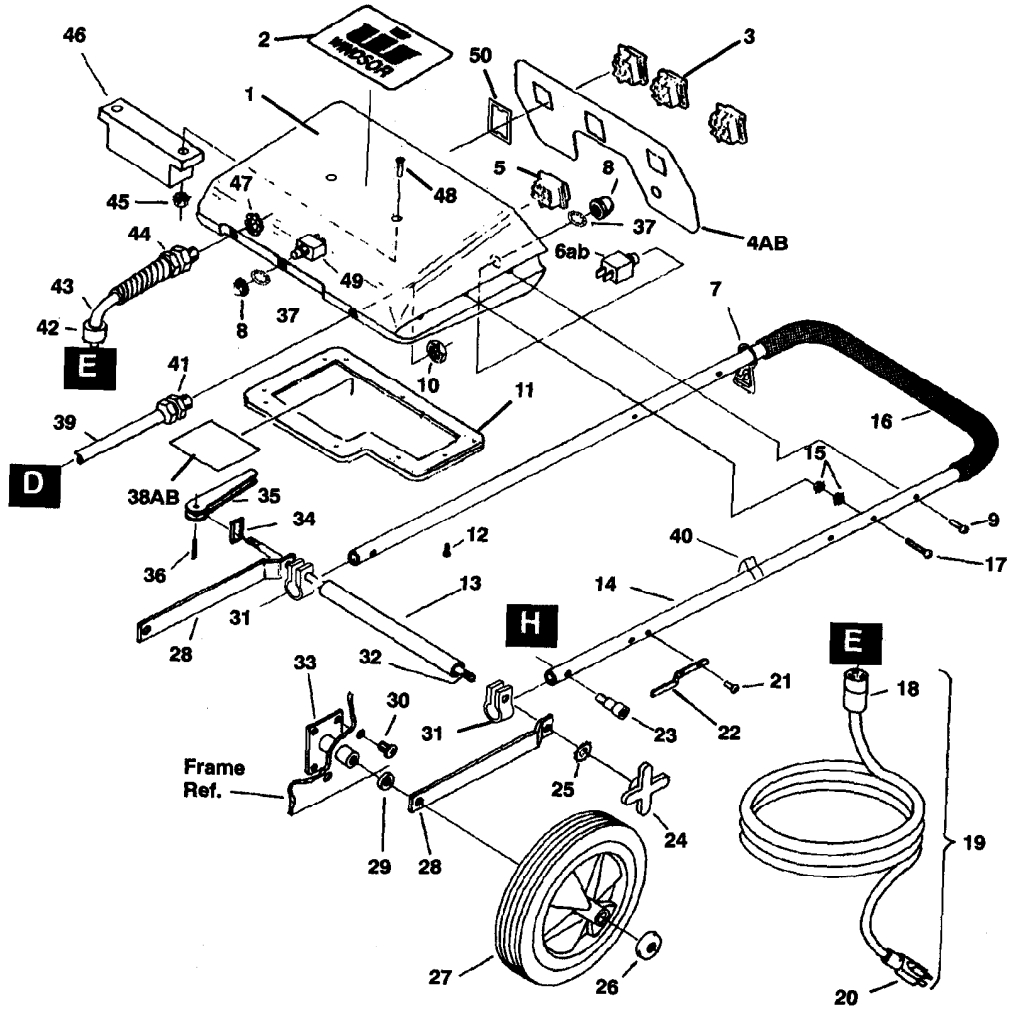

# MAIN HANDLE ASSEMBLY Parts List

| Ref | Qty. | Part No. | Description                     | Serial No. |    | Notes: |
|-----|------|----------|---------------------------------|------------|----|--------|
|     |      |          |                                 | From       | To |        |
| 1   |      | 61214    | Panel, 115V ADM-UL Cntrl w/Rkr  |            |    |        |
| 2   |      | 50184    | Label, Windsor                  |            |    |        |
| 3   |      | 72067    | Switch, 125V SPST Lit Rkr w/BT  |            |    |        |
| 4A  |      | 50451    | Label, S/C Rocker SW            |            |    |        |
| 4B  |      | 50554    | Label; Japan Switch Wiring      |            |    |        |
| 5   |      | 72068    | Switch, 125V SP MOM Lit Rkr     |            |    |        |
| 6a  |      | 14530    | Brkr, 6A Circuit (115V)         |            |    |        |
| 6b  |      | 14832    | Brkr, 6A Circuit VDE (100V)     |            |    |        |
| 7   |      | 73169    | Strain Relief, Cord Hook        |            |    |        |
| 8   |      | 14942    | Boot, 3/8 Circuit Breaker       |            |    |        |
| 9   |      | 70253    | Scr, 10-32 x 1.25 PHMS          |            |    |        |
| 10  |      | 57107    | Nut, Strain Relief M22,5        |            |    |        |
| 11  |      | 62153    | Plate, S/C-UL Panel Access      |            |    |        |
| 12  |      | 70082    | Scr, 6-32 x 1/2 PHMS Nylon      |            |    |        |
| 13  |      | 73180    | Spacer, Handle Adj              |            |    |        |
| 14  |      | 38225    | Handle, ADP w/ Grip             |            |    |        |
| 15  |      | 57104    | Nut, 1 O-32 w/Star Washer       |            |    |        |
| 16  |      | 36123    | Grip, CLP handle x 9.5"         |            |    |        |
| 17  |      | 70092    | Ser.10-32 x 1.5 PHMS            |            |    |        |
| 18  |      | 26009    | Cord End, 115V 15A Fern T/L     |            |    |        |
| 19  |      | 23086    | Cord Asm. 115V. 14/3 x 50'      |            |    |        |
| 20  |      | 26006    | Cord End, 115V 15/A NEMAS-15P   |            |    |        |
| 21  |      | 70361    | Scr, 10-32 x 1/2 PHTR plt       |            |    |        |
| 22  |      | 41144    | Hook, Cord                      |            |    |        |
| 23  |      | 70117    | Shoulder Bolt. 5/16 OD x 1 .OL  |            |    |        |
| 24  |      | 48012    | Knob, Adm Handle 5/16-I 8       |            |    |        |
| 25  |      | 87067    | Washer, 5/16 Star               |            |    |        |
| 26  |      | 41236    | Cap, Wheel hub                  |            |    |        |
| 27  |      | 89114    | Wheel, 10" Dia.                 | 408644     | -  |        |
| 28  |      | 05076    | Arm, ADM 8G Handle              |            |    |        |
| 29  |      | 73214    | Spacer, Adm Wheel               |            |    |        |
| 30  |      | 70189    | Scr, 1/4-20 x 5/16 PHMS         |            |    |        |
| 31  |      | 20084    | Clamp, Handle Adj Lock          |            |    |        |
| 32  |      | 67073    | Rod. Handle Adj Lock            |            |    |        |
| 33  |      | 03073    | Axle Asm, Wheel                 |            |    |        |
| 34  |      | 27226    | Clip, Handle Lever Adj          |            |    |        |
| 35  |      | 51039    | Lever, Handle clamp             |            |    |        |
| 36  |      | 66068    | Pin, 1/8 OD x 5/8 L Roll        |            |    |        |
| 37  |      | 87100    | Washer, 3/8 ID int. lock        |            |    |        |
| 38A |      | 50534    | Label, 115V Wirina Diagram      |            |    |        |
| 38B |      | 50503    | Label, 1 OOV Wiring Diagram     |            |    |        |
| 39  |      | 88885    | Wire Asm, 115V 16/5             |            |    |        |
| 40  |      | 27371    | Clip, Power cord                |            |    |        |
| 41  |      | 7320 1   | Strain Relief, .546 ID          |            |    |        |
| 42  |      | 26015    | Cord End, 125V 15A M. T/L       |            |    |        |
| 43  |      | 23506    | Cord Asm, ADM-UL Pigtail        |            |    |        |
| 44  |      | 73200    | Strain Relief, Flexible 1/2 NPT |            |    |        |
| 45  |      | 57106    | Nut, 8-32 w/ Star Washer        |            |    |        |
| 46  |      | 14022    | Terminal Block, 115V/230V (6-6) |            |    |        |
| 47  |      | 57040    | Nut, 1/2 NPT'                   |            |    |        |
| 48  |      | 70252    | Scr, 8-32 x 1" FHMS Nylon       |            |    |        |
| 49  |      | 14700    | Breaker, 15A Circuit            |            |    |        |
| 50  |      | 27376    | Clip, Switch retaining          |            |    |        |

# BRUSH DRIVE ASSEMBLY

## Belt Replacement

Periodically check the drive belt for wear.  
Replace worn or frayed belts before they break, when possible.

To access the belt remove the belt cover.

To replace the belt it is necessary to loosen the motor and remove the brush.

The "preset" belt tension is correct when the motor and belt are securely back in place.

Check pulley alignment and correct if necessary.  
The brush pulley and motor pulley can be aligned using a straight edge.

Ensure that both protective covers are back in place before operating the machine.

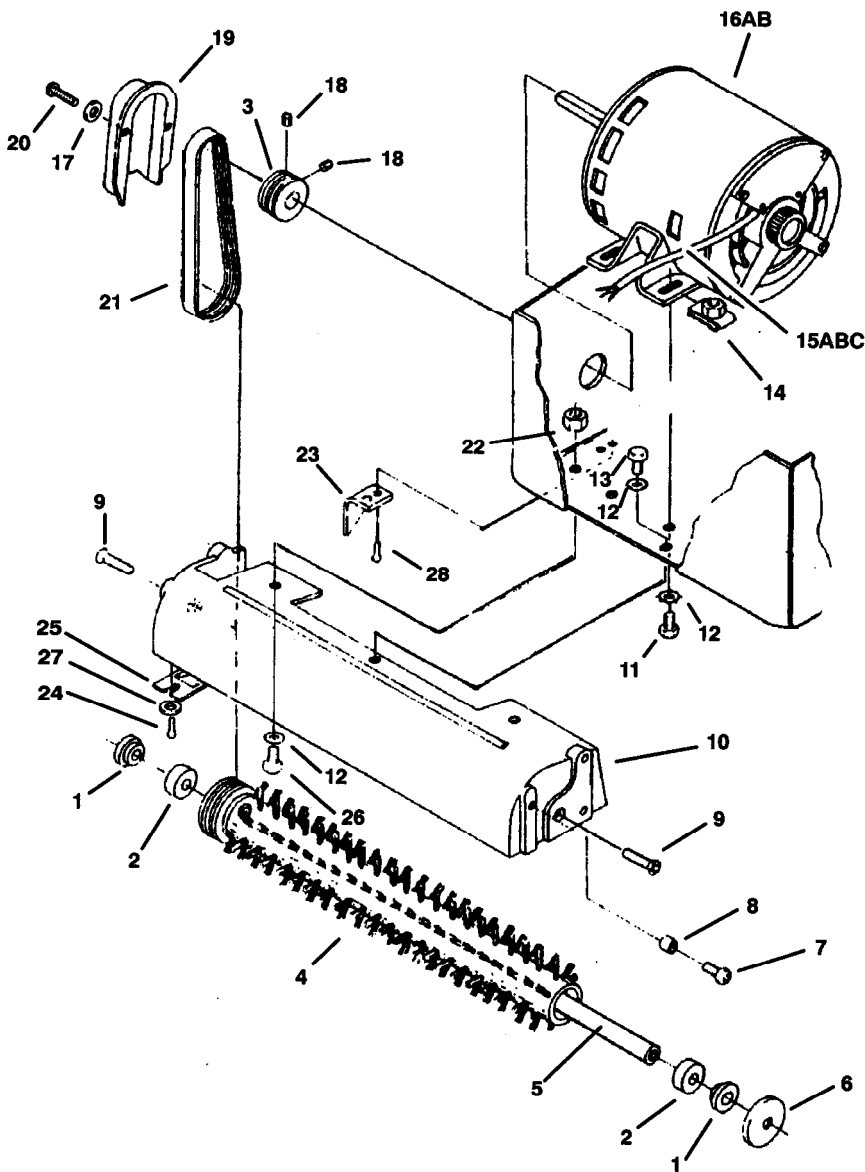

# BRUSH DRIVE ASSEMBLY Parts List

| Ref | Qty. | Part No. | Description                    | Serial No. |    | Notes: |
|-----|------|----------|--------------------------------|------------|----|--------|
|     |      |          |                                | From       | To |        |
| 1   |      | 73207    | Spacer, Brush                  |            |    |        |
| 2   |      | 09019    | Bearing, Brush                 |            |    |        |
| 3   |      | 64022    | Pulley, Motor                  |            |    |        |
| 4   |      | 14219    | Brush. ADP assembly            |            |    |        |
| 5   |      | 03033    | Axle, Brush                    |            |    |        |
| 6   |      | 36054    | Guard, Thread                  |            |    |        |
| 7   |      | 70190    | Scr, 1/4-20 x 1/2 BHCS         |            |    |        |
| 8   |      | 73181    | Spacer, .259 ID x .38x .25     |            |    |        |
| 9   |      | 70562    | Scr, 1/4-20 x 5/8 FHCS DL      |            |    |        |
| 10  |      | 41109    | Housing, Brush                 |            |    |        |
| 11  |      | 70011    | Scr, 1/4-20 x 5/8 HHCS         |            |    |        |
| 12  |      | 87025    | Washer, 1/4 Star               |            |    |        |
| 13  |      | 70020    | Scr, 1/4-20 x 1/2 HHCS         |            |    |        |
| 14  |      | 57123    | Nut, 1/4-20 Captive            |            |    |        |
| 15A |      | 88552    | Wire, 16' Wht/18 76028 x 76046 |            |    |        |
| 15B |      | 88883    | Wire, 13" Blk/18 76040 x 76046 |            |    |        |
| 15C |      | 88884    | Wire; 14" Grn/18 76008 x 76008 |            |    |        |
| 16A |      | 53093    | Motor, 115V Brush              |            |    |        |
| 16B |      | 53173    | Motor, 1 OOV Brush             |            |    |        |
| 17  |      | 87018    | Washer, #10 Flat               |            |    |        |
| 18  |      | 70074    | Scr, 1 O-32 x 1/4 KCP          |            |    |        |
| 19  |      | 36044    | Guard, belt                    |            |    |        |
| 20  |      | 70363    | Scr, 10-32 x 3/8 PHTR          |            |    |        |
| 21  |      | 11015    | Belt                           |            |    |        |
| 22  |      | 57047    | Nut, 1/4-32 Nylock             |            |    |        |
| 23  |      | 36050    | Gusset, Belt Guard             |            |    |        |
| 24  |      | 70434    | Scr, 6-32 x 3/8 PPHTF          |            |    |        |
| 25  |      | 36043    | Guard, Brush Pulley            |            |    |        |
| 26  |      | 70015    | Scr, 1/4-20 x 3/4 HHCS         |            |    |        |
| 27  |      | 87161    | Washer, #6 Flat SAE Pltd.      |            |    |        |
| 28  |      | 67005    | Rivet, 1/8 OD Wht AL           |            |    |        |

# Wiring Diagram

## 100V ADPJ

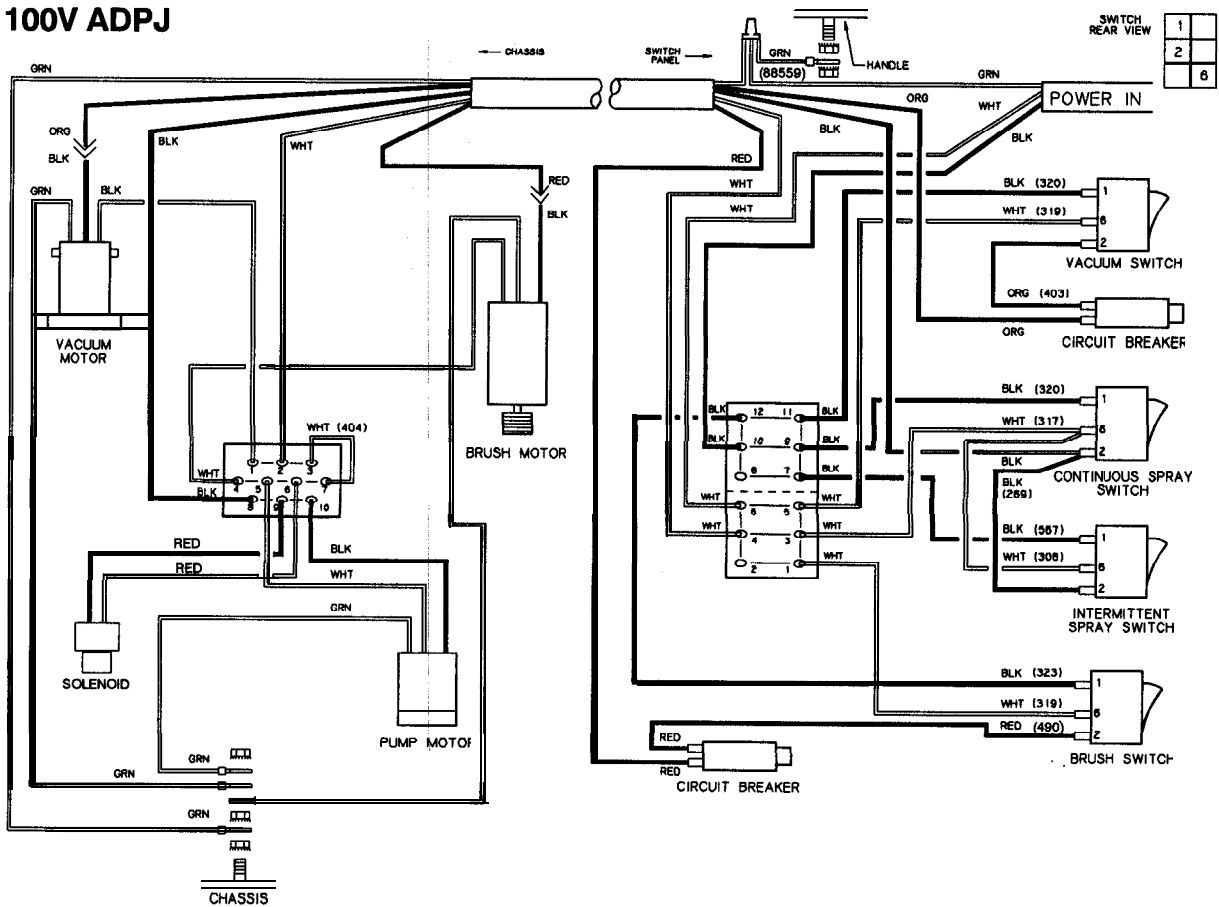

## 115V ADP

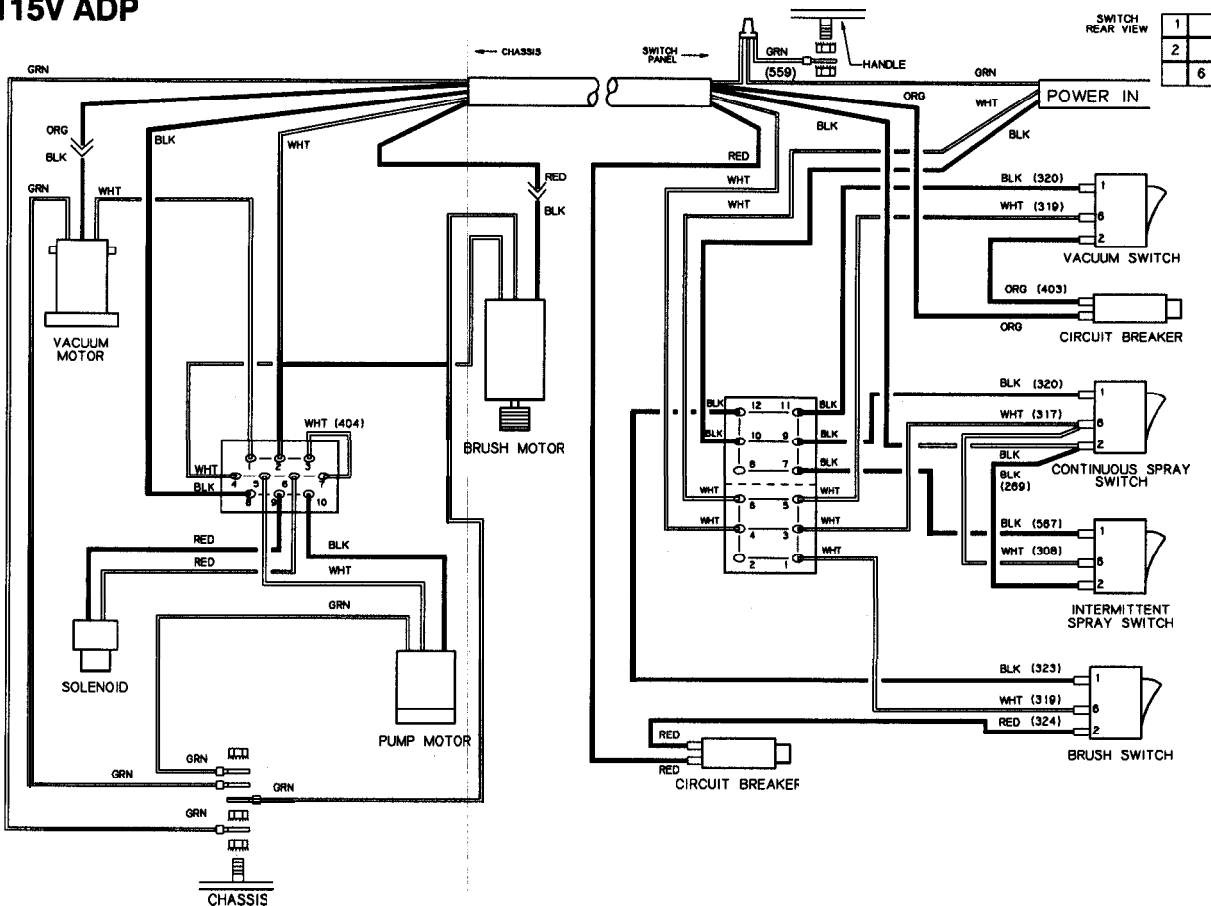

**Notes:**





## **LIMITED WARRANTY**

Windsor Industries, Inc. warrants new machines against defects in material and workmanship under normal use and service to the original purchaser. The warranty period is subject to the conditions stated below.

### **3 YEARS FOR PARTS AND 1 YEAR FOR SERVICE LABOR**

Exceptions: Rotationally molded polyethylene tanks carry a 6 year parts and 1 year service labor warranty. VERSAMATIC® models carry a 3 year warranty on brush motors, vacuum motors, and belts, and a 1 year service labor warranty. SENSOR® models carry a 2 year warranty on vacuum motors and belts, and a 1 year service labor warranty. Extractor brush motors, pump motors, pc boards and electronics, vac motors (other than VERSAMATIC® and SENSOR®), pumps, and FLEXSOL™ diaphragms, all RADIUS™, all AXCESS™ and TITAN™1 carry a 1 year parts and service labor warranty. Propane equipment has a 1 year parts and service warranty. The Orjan® engines have a 3 year manufacturers' warranty. The Honda® engines have a 2 year manufacturers' warranty. The engine warranty is administered through the engine manufacturer and must be repaired at an authorized service center.

Normal wear items including, but not limited to, belts, brushes, capacitors, carbon brushes, casters, clutches, cords, filters, finishes, gaskets, hoses, light bulbs, rectifiers, switches, squeegees, bearings, pulleys, relays, actuating cables, tires and wheels will be warranted for manufacturing defects for 90 days from the purchase date.

The warranty commences on the purchase date by the original end user from an authorized Windsor Agent, subject to proof of purchase. The Machine Registration Card must be completed and returned immediately at the time of purchase. If proof of purchase cannot be identified, the warranty start date is 90 days after date of sale to an authorized Windsor distributor. Parts replaced or repaired under warranty are guaranteed for the remainder of the original warranty period.

### **90 DAY WARRANTY EXTENSION AVAILABLE**

Upon receipt of the Machine Registration Card, Windsor will extend the warranty period an additional 90 days from the purchase date. Does not include items warranted 90 days for manufacturing defects.

### **STATED WARRANTIES ARE IN LIEU OF ALL OTHER WARRANTIES, EXPRESSED OR IMPLIED.**

Any statutory implied warranties, including any warranty of merchantability or fitness for a particular purpose, are expressly limited to the duration of this written warranty. Windsor will not be liable for any other damages, including but not limited to indirect or special consequential damages arising out of or in connection with the furnishing; performance, use or inability to use the machine. This remedy shall be the exclusive remedy of the buyer.

This warranty shall not apply to: 1.damage in transit; 2.misuse or abuse(including the use of incompatible or corrosive chemicals or overloading of capacity); 3. failure due to lack of proper maintenance and care (including cleaning); 4.any design alterations performed by an organization not authorized or specified by Windsor; 5.batteries and chargers. 6. high pressure washing. 7.electrical components exposed to moisture.

If difficulty develops during the warranty period, contact the authorized Windsor Agent from whom the product was purchased. Windsor, Inc. may elect to require the return of components to validate a claim. Any defective part to be returned must be shipped freight pre-paid to an authorized Windsor Distributor/Service Center or to the Windsor factory.

### **USE OF PARTS NOT APPROVED BY WINDSOR, INC. WILL VOID ALL WARRANTIES.**

This warranty is valid only for all products sold after July 1, 1995. A product sold before that date shall be covered by the limited Warranty in effect at the date of sale to the original purchaser.



**WINDSOR INDUSTRIES, INC., 1351 W. Stanford Ave., Englewood, CO 80110 USA**  
Phone: 303-762-1800 Fax: 303-762-0817 Internet: [www.windsorind.com](http://www.windsorind.com)