

chariot

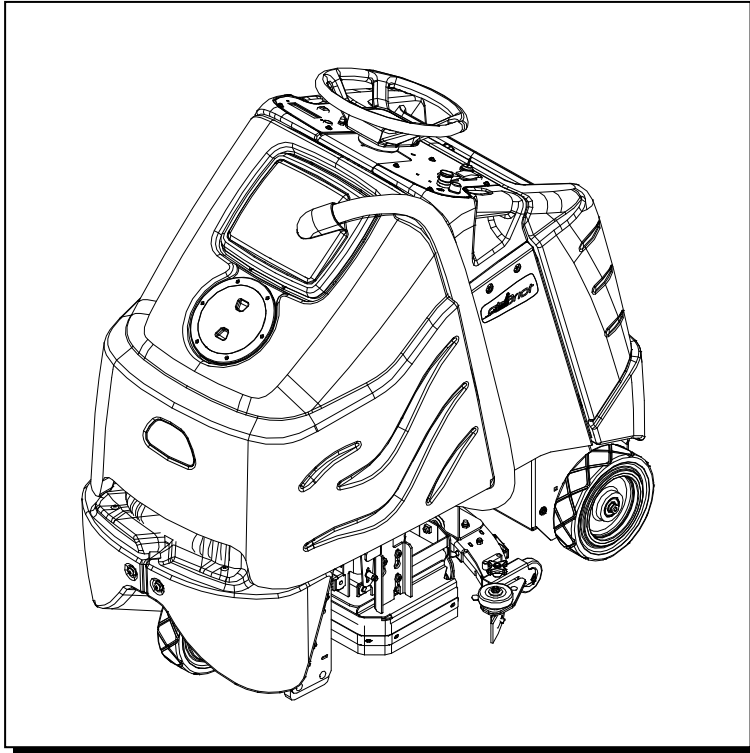

iSCRUB



Operating Instructions (ENG)

MODELS:	CS24 10060210	CSE24 10060250	CS24SP 10060220
	CSX24 10060270	CSXE24 10060290	CSE24SP 10060260
	CSXE024 10060300		



QUEST® ... for Continuous Improvement.
Windsor's Quality Management System is Certified ISO 9001.

Read these instructions before using the machine



86037660
04/30/18



CLICK TO ORDER PARTS

MACHINE DATA LOG/OVERVIEW

MODEL _____
DATE OF PURCHASE _____
SERIAL NUMBER _____
SALES REPRESENTATIVE # _____

YOUR DEALER
Name: _____
Address: _____
Phone Number: _____

OVERVIEW

The Chariot Scrubber is a battery powered, stand-on, hard floor scrubber intended for commercial use. The appliance applies a cleaning solution onto a hard floor, scrubs the floor with brushes or pads, and then vacuums the soiled water back into the recovery tank.

TABLE OF CONTENTS

Machine Data Log/Overview.....	2
Table Of Contents	3

HOW TO USE THIS MANUAL

How To Use This Manual.....	1-1
-----------------------------	-----

SAFETY

Important Safety Instructions	2-1
Hazard Intensity Level.....	2-2
Safety Label Location.....	2-3

OPERATIONS

Technical Specifications.....	3-1
How The Machine Works.....	3-3
Components	3-4
Drive Controls.....	3-5
Scrub Controls-Basic & Cylindrical	3-9
Scrub Controls-Deluxe	3-11
Scrub Controls-Squeegee.....	3-13

Machine Operation.....	3-15
Pre-Run Machine Inspection.....	3-15
Starting Machine	3-15
Emergency Stop Procedures	3-15
Filling Solution Tank.....	3-16
Normal Scrubbing.....	3-16
To Begin Scrubbing.....	3-17
Priming Pump.....	3-17
To Stop Scrubbing.....	3-18
Double Scrub.....	3-18
Emptying And Cleaning Tanks.....	3-19

MAINTENANCE

Service Schedule	4-1
Batteries.....	4-2
Squeegee.....	4-6
Scrub Brushes.....	4-9
Scrub Deck-Disk.....	4-10
Scrub Deck-Cylindrical.....	4-13
Circuit Protection.....	4-18
Solution Strainer & Pump-Disk.....	4-19
Solution Strainer & Pump-Cylindrical.....	4-20
Vacuum & Float Shut-Off	4-22
Drive Motor & Brake.....	4-24
Bag Replacement.....	4-27
Transporting Machine.....	4-28
Machine Troubleshooting.....	4-29

GROUP PARTS LIST

Bumper.....	5-1
Control Panel-Basic-Cylindrical.....	5-3
Control Panel-Deluxe	5-5
Control Panel Housing.....	5-7
Decal.....	5-9
Frame-Lower	5-11
Frame-Upper	5-13
Pedal Platform.....	5-15
Rear Cover	5-19
Scrub Brush/Pad Driver.....	5-21
Scrub Deck - Disk.....	5-23
Scrub Deck – Cylindrical	5-25
Scrub Deck Aqua-Mizer™.....	5-27
Side Squeegee – Cylindrical	5-29
Scrub deck – Side Squeegee – Cylindrical	5-31
Scrub Deck Skirts.....	5-33
Scrub Deck Lift	5-35
Scrub Deck Mounting- Cylindrical	5-37
Scrub Deck Actuator – Cylindrical.....	5-39
Solution Cylindrical.....	5-41
Solution Disk.....	5-43
Squeegee - Disk.....	5-45
Squeegee – Cylindrical.....	5-47
Squeegee Lift-Basic	5-49
Squeegee Lift-Deluxe	5-51
Squeegee Swing	5-53
Squeegee Lift – Cylindrical.....	5-55
Steering	5-59
Tank.....	5-61
Vacuum.....	5-63
Wheel-Front Drive, Chain.....	5-65
Wheel-Front Drive, Gear	5-67
Wheel-Front Brake	5-69
Wheel-Rear.....	5-71
Wiring-Batteries	5-73
Wiring-Components.....	5-75
Wiring-Control Panel-Basic-Cylindrical	5-77
Wiring-Control Panel-Deluxe	5-79
Wiring-Drive Motor.....	5-81
Wiring-Main Harness	5-83
Wiring-Pedal Platform.....	5-85
Wiring Diagram-Basic-Cylindrical.....	5-87
Wiring-Diagram-Deluxe	5-88
Hose Diagram-Disk	5-89
Hose Diagram-Cylindrical.....	5-90
Suggested Spare Parts	5-91

OPTIONS

Back-Up Alarm – Option.....	6-1
Battery Cart – Option.....	6-3
Seat – Option.....	6-7
Warning Light – Option.....	6-9
EC Declaration of Conformity.....	6-11
Serial Numbers.....	6-14
Warranty.....	

HOW TO USE THIS MANUAL

This manual contains the following sections:

- HOW TO USE THIS MANUAL
- SAFETY
- OPERATIONS
- MAINTENANCE
- PARTS LIST

The HOW TO USE THIS MANUAL section will tell you how to find important information for ordering correct repair parts.

Parts may be ordered from authorized Windsor dealers. When placing an order for parts, the machine model and machine serial number are important. Refer to the MACHINE DATA box which is filled out during the installation of your machine. The MACHINE DATA box is located on the inside of the front cover of this manual.

MODEL _____
DATE OF PURCHASE _____
SERIAL NUMBER _____
SALES REPRESENTATIVE # _____

The model and serial number of your machine are located below the battery compartment of the machine.

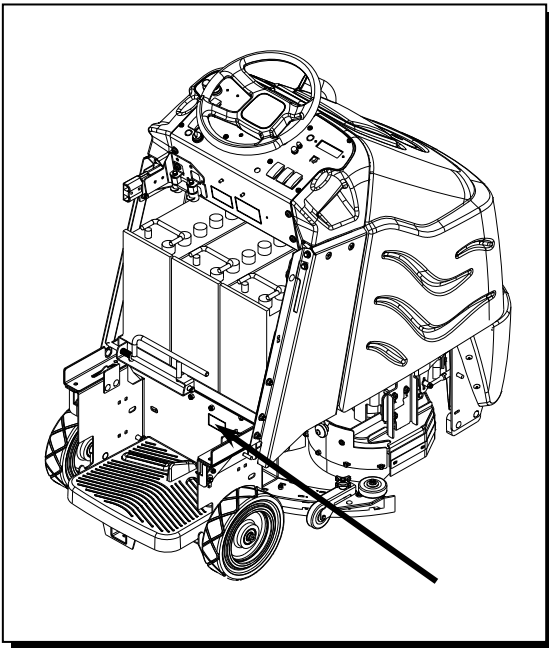

The SAFETY section contains important information regarding hazard or unsafe practices of the machine. Levels of hazards are identified that could result in product or personal injury, or severe injury resulting in death.

The OPERATIONS section is to familiarize the operator with the operation and function of the machine.

The MAINTENANCE section contains preventive maintenance to keep the machine and its components in good working condition. They are listed in this general order:

- Batteries
- Scrub Brushes
- Adjusting Squeegee
- Service Schedule
- Machine Troubleshooting

The PARTS LIST section contains assembled parts illustrations and corresponding parts list. The parts lists include a number of columns of information:

- **REF** – column refers to the reference number on the parts illustration.
- **PART NO.** – column lists the part number for the part.
- **PRV NO.** - Reference No.
- **QTY** – column lists the quantity of the part used in that area of the machine.
- **DESCRIPTION** – column is a brief description of the part.
- **SERIAL NO. FROM** – If this column has an (*) and a Reference number, see the SERIAL NUMBERS page in the back of your manual. If column has two asterisk (**), call manufacturer for serial number. The serial number indicates the first machine the part number is applicable to. The main illustration shows the most current design of the machine. When a boxed illustration is shown, it displays the older design.
- **NOTES** – column for information not noted by the other columns.

NOTE: If a service or option kit is installed on your machine, be sure to keep the KIT INSTRUCTIONS which came with the kit. It contains replacement parts numbers needed for ordering future parts.

NOTE: The number on the lower left corner of the front cover is the part number for this manual.

IMPORTANT SAFETY INSTRUCTIONS

When using an battery powered appliance, basic precaution must always be followed, including the following:

READ ALL INSTRUCTIONS BEFORE USING THIS MACHINE.



To reduce the risk of fire, electric shock, or injury:

Use only indoors. Do not use outdoors or expose to rain.

Use only as described in this manual. Use only manufacturer's recommended components and attachments.

If the machine is **not working properly**, has been dropped, damaged, left outdoors, or dropped into water, return it to an authorized service center.

Do not operate the machine with any openings blocked. Keep openings free of debris that may reduce airflow.

This machine **is not** suitable for picking up hazardous dust.

Machine can cause a fire when operating near flammable vapors or materials. Do not operate this machine near flammable fluids, dust or vapors.

This machine is suitable for commercial use, for example in hotels, schools, hospitals, factories, shops and offices for more than normal housekeeping purposes.

Maintenance and repairs **must be done** by qualified personnel.

If foam or liquid comes out of machine, **switch off immediately**.

Disconnect battery before cleaning or servicing.

Before the machine is discarded, the batteries **must be removed** and properly disposed of.

Make sure all warning and caution labels **are legible and properly attached** to the machine.

During operation, attention shall be paid to other persons, especially children.

Before use all covers and doors shall be put in the positions specified in the instructions.

When leaving unattended, secure against unintentional movement.

The machine shall only be operated by instructed and authorized persons.

When leaving unattended, switch off or lock the main power switch to prevent unauthorized use.

Only chemicals recommended by the manufacturer shall be used.

This appliance has been designed for use with the brushes specified by the manufacturer. The fitting of other brushes may affect its safety.

Do not use on surfaces having a gradient of over 10% (6 degrees).

SAVE THESE INSTRUCTIONS

HAZARD INTENSITY LEVEL

The following symbols are used throughout this guide as indicated in their descriptions:

HAZARD INTENSITY LEVEL

There are three levels of hazard intensity identified by signal words -**WARNING** and **CAUTION** and **FOR SAFETY**. The level of hazard intensity is determined by the following definitions:



WARNING - Hazards or unsafe practices which COULD result in severe personal injury or death.



CAUTION - Hazards or unsafe practices which could result in minor personal injury or product or property damage.

FOR SAFETY: To Identify actions which must be followed for safe operation of equipment.

Report machine damage or faulty operation immediately. Do not use the machine if it is not in proper operating condition. Following is information that signals some potentially dangerous conditions to the operator or the equipment. Read this information carefully. Know when these conditions can exist. Locate all safety devices on the machine. Please take the necessary steps to train the machine operating personnel.

FOR SAFETY:

DO NOT OPERATE MACHINE:

Unless Trained and Authorized.

Unless Operation Guide is Read and understood.

In Flammable or Explosive areas.

In areas with possible falling objects.

WHEN SERVICING MACHINE:

Avoid moving parts. Do not wear loose clothing; jackets, shirts, or sleeves when working on the machine. Use Windsor approved replacement parts.



Batteries emit hydrogen gas. Explosion or fire can result. Keep sparks and open flame away. Keep solution tank in raised position when charging. Keep sparks and flames away from the batteries. Do not smoke around batteries.



Disconnect batteries before working on machine. Only qualified personnel should work inside machine. Always wear eye protection and protective clothing when working on or near batteries. Avoid skin contact with the acid contained in the batteries.



Never allow metal to lie across battery tops.

SAFETY LABEL LOCATION

NOTE: These drawings indicate the location of safety labels on the machine. If at any time the labels become illegible, promptly replace them.

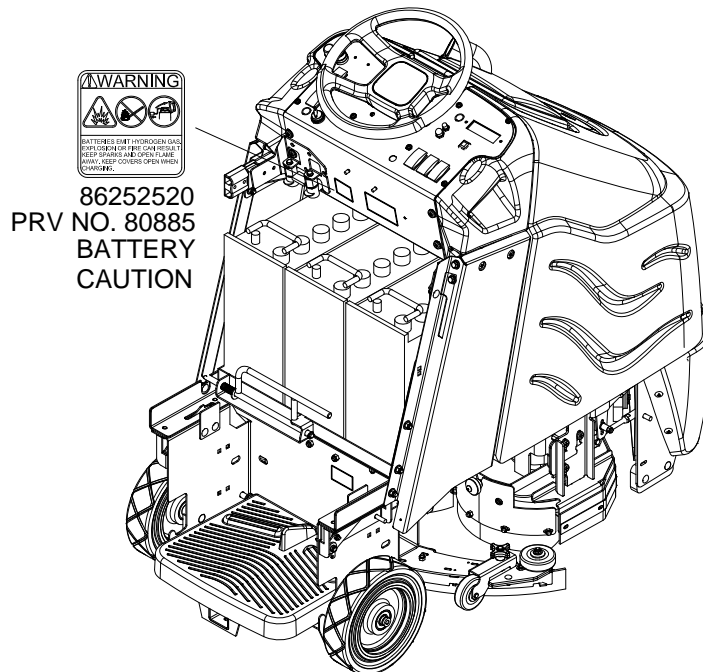
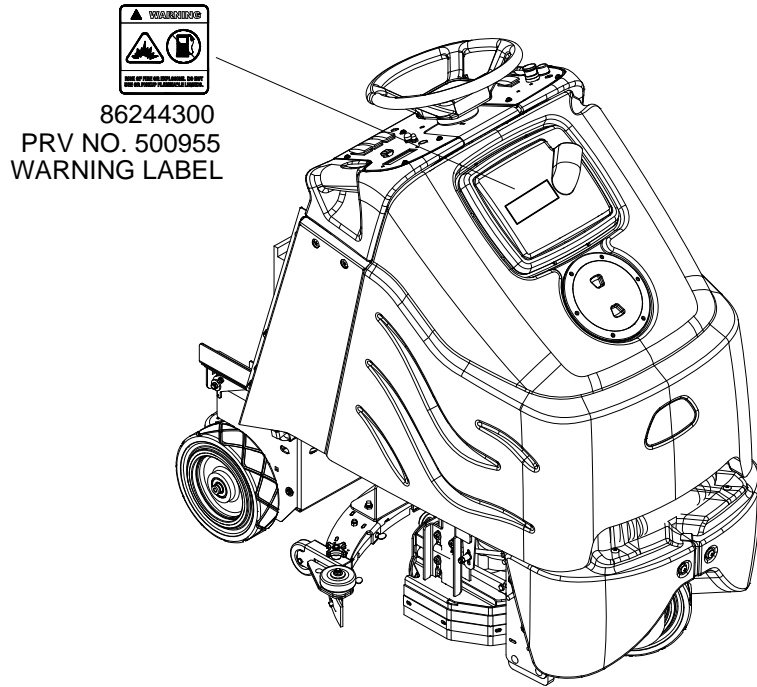

TECHNICAL SPECIFICATIONS

ITEM	DIMENSION/CAPACITY
Nominal power	2100 W
Rated Voltage	36 Volts DC
Rated Amperage	58 amps
Batteries	3 X12 Volt 195-215 AH @ 20 hr. rate
Battery Compartment Dimensions	21 in. x 16 in. x 17 in. tall (533mm x 406mm x 432mm)
Scrub Brush Motors - Disk Machine	2 x .3 HP (190 W)
Scrub Brush Motors - Cylindrical Machine	2 x .75 HP (560 W)
Vacuum Motor(s)	.75 HP (560 W)
Maximum flow rate of vacuum motor	77.0 cfm (36.4 liters per second)
Maximum suction of vacuum motor	81.8 inches of water (20.3 kPa)
Propelling Motor	.75 HP (560 W)
Mass (GVW)	1245 lbs (565 kg)
Weight empty without batteries	535 lbs (243 kg)
Solution Control	1.3 GPM pump, fully variable with automatic shut-off in neutral
Solution capacity	25 gal (95 L)
Recovery capacity	25 gal (95 L)
Scrub brush diameter - Disk Machine	12 inch (305 mm)
Scrub brush diameter - Cylindrical Machine	6 inch (152 mm)
Scrub brush pressure	0-150lbs (0-667N)
Scrub brush speed - Disk Machine	300 rpm
Scrub brush speed - Cylindrical Machine	800 rpm
Tires	10 in. (254mm) Solid Scrubber Compound
Foundation Pressure	104 psi (715 Kpa)
Maximum Speed	3.5 miles/hour (5.6 Km/hour)
Theoretical Coverage	24,200 ft ² /hr @ 2.5 mph with 2 in. overlap
Frame Construction	Powder coated steel
Brake	Electrical parking brake, sets automatically whenever operator steps off platform or engages emergency stop.
Minimum aisle u-turn width	56 in. (1425 mm)
Maximum rated climb and descent angle	7.5 degrees

TECHNICAL SPECIFICATIONS

ITEM	MEASURE
Height	50.6 inches (1285 mm)
Length	52.5 inches (1330 mm)
Width without squeegee	26.5 inches (670 mm)
Width of squeegee - Disk Machine	32.7 inches (830 mm)
Width of squeegee - Cylindrical Machine	29 inches (737 mm)
Width of scrub path - Disk Machine	24 inches (610 mm)
Width of scrub path - Cylindrical Machine	23 inches (585 mm)

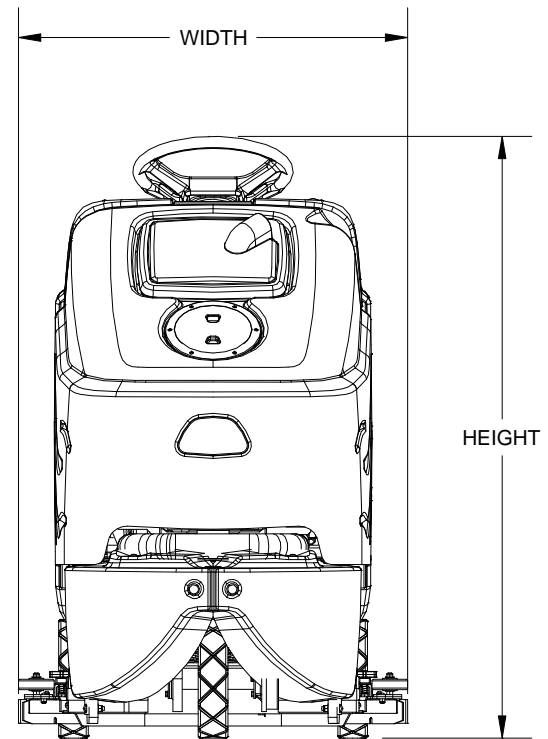
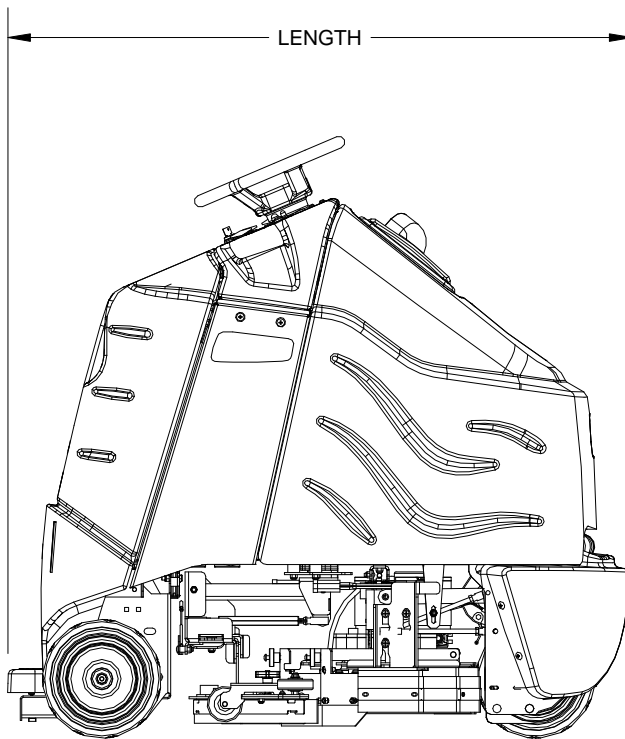

SPECIAL NOTES:

The sound pressure level at the operator's ear was measured to be 68 dBA. This was a nearfield, broad-band measurement taken in a typical industrial environment on a tile floor. This appliance contains no possible source of impact noise. The instantaneous sound pressure level is below 63 Pa.

The weighted root mean square acceleration at the operator's arms was measured to be below 2.5m/s^2 . This was a tri-axial, third-octave-band measurement made during normal operation on a composite tile floor. The measurement and related calculations were made in accordance with ANSI S3.34-1986.

This appliance is not intended for use by persons (including children) with reduced physical, sensory or mental capabilities, or lack of experience and knowledge, unless they have been given supervision or instruction concerning use of the appliance by a person responsible for their safety. Children should be supervised to ensure that they do not play with the appliance.

HOW THIS MACHINE WORKS

The Chariot® is a battery powered, self-propelled, hard floor scrubber intended for commercial use. The appliance applies a cleaning solution onto a hard floor, scrubs the floor with brushes, and then vacuums the soiled water back into the recovery tank.

The machine's primary systems are the solution system, scrub system, recovery system, and operator control system.

The function of the solution system is to store cleaning solution and deliver it to the scrub system. The solution system consists of the solution tank, strainer, pump, valve and controls. The solution tank stores cleaning solution (water and detergent) until it is delivered to the scrub system. The strainer protects the pump from debris. The valve automatically prevents solution flow unless the scrub brushes are turned on and the machine is being propelled. The solution control switch controls the amount of cleaning solution delivered to the scrub system by controlling the amount of time the pump is on.

The function of the scrub system is to scrub the floor. The disk scrub system consists of two rotary type disk scrub brushes, motors, scrub deck skirt, lift actuator and controls. The brushes scrub the floor as the motors drive the brushes. The brush drive hubs allow the scrub brushes to follow irregularities and changes in the floor without losing contact with the floor. The scrub deck skirts control the cleaning solution on the floor so that the squeegee can pick it up. The one touch/brush switch controls the motors and lift actuator to turn the motors on and lower the deck, or turn the motors off and raise the deck. The brush pressure switch controls the down pressure on the scrub deck.

The scrub plus system consists of two cylindrical type brushes, motors, scrub deck side squeegees, hopper, lift actuator, and controls. The cylindrical scrub head is designed to eliminate debris that may be caught in the squeegee while scrubbing. Water is applied to the first scrubbing brush turning in a clockwise rotation when viewed from the right side of machine. The first brush scrubs dirt and debris between the brushes. The second scrubbing brush, turning in a counter clockwise rotation, picks up debris and throws it into a removable hopper. Water is allowed to drain out the hopper into the squeegee path where it is recovered from the floor.

The scrub deck side squeegees control the cleaning solution on the floor so that the squeegee can pick it up. The brush pressure switch controls the motors and lift actuator to turn the motors on and lower the deck, or turn the motors off and raise the deck. The brush pressure switch also controls the down pressure on the scrub deck.

The function of the recovery system is to vacuum the soiled water back into the recovery tank. The recovery system consists of the squeegee, vacuum motor, float ball filter, recovery bag and controls. The squeegee wipes the dirty solution off the floor as the machine moves forward. The vacuum motor provides suction to draw the dirty solution off the floor and into the recovery bag. The float ball filter protects the vacuum fan from debris and foam. The recovery bag stores the dirty solution.

The function of the operator control system is to control the direction and speed of the machine. The directional control system consists of the direction control switch, throttle pedal, operator presence pedal, speed control switch, drive reset switch, emergency stop/brake switch, steering wheel, propel controller, and drive wheel. The directional control switch signals forward or reverse direction. The controller interprets signals from the throttle pedal to command the drive wheel to propel or slow the machine. The drive reset switch is to make sure the operator is on platform before machine will propel. The operator presence pedal is to make sure the operator keeps both feet safely on platform while driving. The steering wheel points the drive wheel in the direction desired by the operator. The parking brake automatically engages when the operator steps off the platform. The emergency stop/brake can be used to hold the machine on slopes.

COMPONENTS

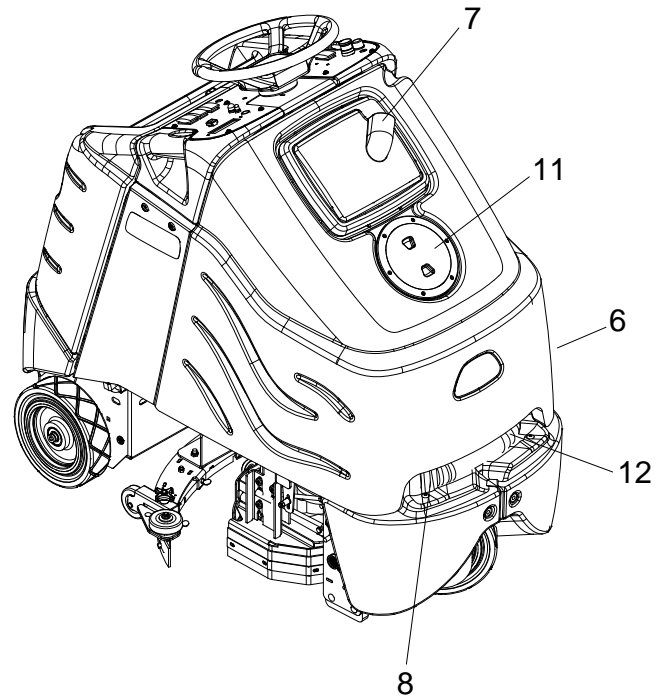
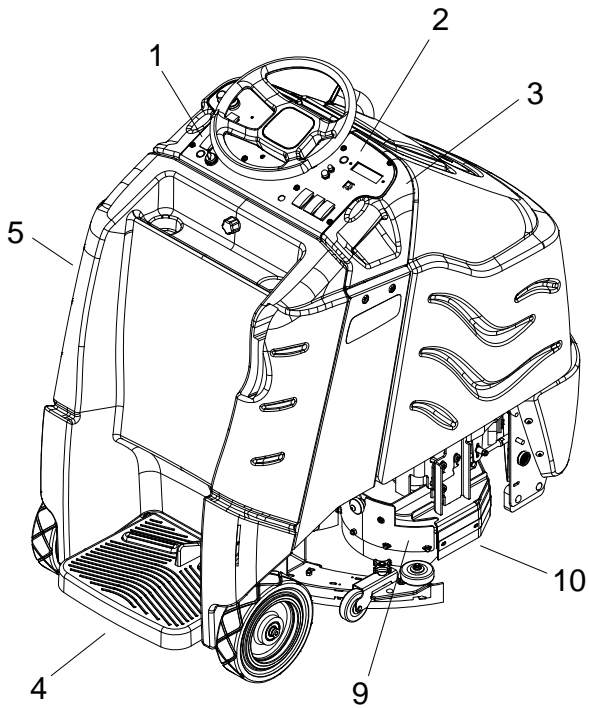

-
1. Control Panel-Drive
 2. Control Panel-Scrub
 3. Control Housing
 4. Pedal Platform
 5. Rear Cover
 6. Tank

7. Recovery Dome
8. Recovery Drain Hose
9. Scrub Deck Aqua-Mizer
10. Scrub Deck Skirts/Side Squeegees
11. Solution Cover
12. Solution Drain Hose

DRIVE CONTROLS

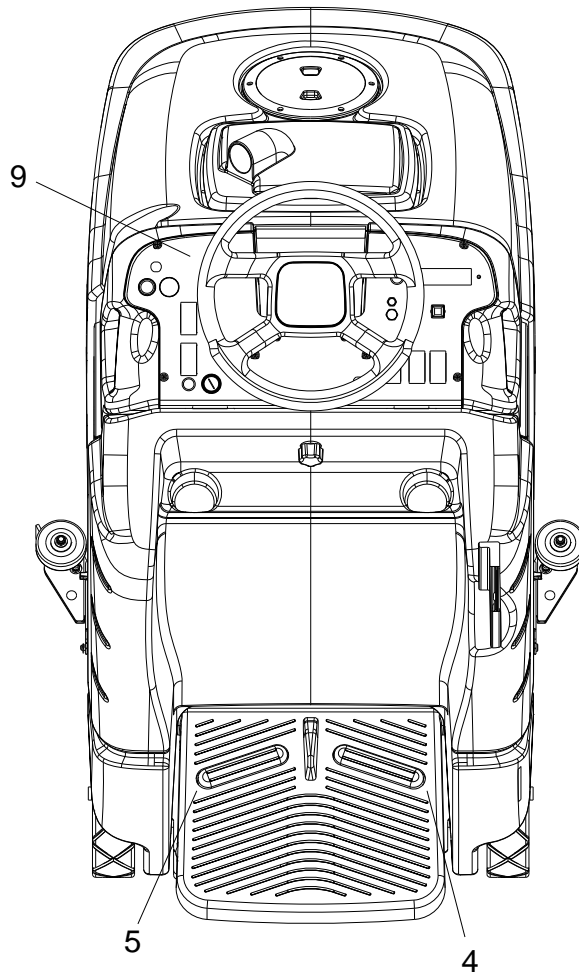
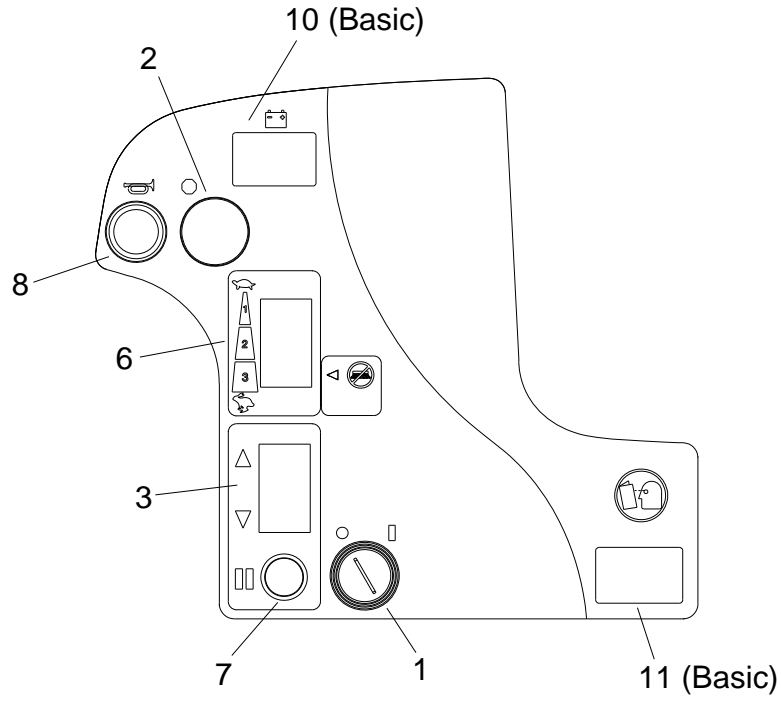

- | | |
|---------------------------------------|---|
| 1. <i>Key Switch</i> | 7. <i>Drive Reset Button</i> |
| 2. <i>Emergency Stop/Brake Switch</i> | 8. <i>Horn Button</i> |
| 3. <i>Directional Control Switch</i> | 9. <i>Steering Wheel</i> |
| 4. <i>Throttle Pedal</i> | 10. <i>Battery Discharge Indicator (Basic Only)</i> |
| 5. <i>Operator Presence Pedal</i> | 11. <i>Hour Meter (Basic Only)</i> |
| 6. <i>Speed Control Switch</i> | |
-

1. KEY SWITCH

Controls the power for machine functions.

To turn the machine power on, rotate key clockwise.

To turn the machine off, rotate key counterclockwise.

Deluxe Only: When the key is turned on the battery symbol will flash while the system runs self-diagnostics and returns scrub deck and squeegee to their raised positions, if necessary. The controller will not respond to other commands until this routine is complete.

2. EMERGENCY STOP/BRAKE SWITCH

This safety feature is designed to cut all power to the machine at any time and apply parking brake.

To shut the machine power off, push the Emergency Stop Switch, this will also engage the parking brake and cause the machine to stop immediately.

To reset the machine, rotate the switch clockwise.

3. DIRECTIONAL CONTROL SWITCH

Controls the direction of travel of the vehicle. The position of the switch indicates direction of travel.

To travel forward, press the top of the switch.

To travel in reverse, press the bottom of the switch.

4. THROTTLE PEDAL

Controls the speed of the vehicle within the speed control setting selected. Pressing the pedal causes the machine to travel in the direction selected by the Directional Control Switch.

To increase speed, increase pressure on the pedal.

To decrease speed, decrease pressure on the pedal.

5. OPERATOR PRESENCE PEDAL

This safety feature is designed to ensure that the operator has their left foot on pedal platform whenever machine is moving. The operator must have left foot on Operator Presence Pedal for machine to move.

DRIVE CONTROLS

6. SPEED CONTROL SWITCH

Controls the maximum speed of the machine. There are two setting intended for scrubbing, speeds 1 and 2. Speed 3 is recommended for transport only, not scrubbing.

To increase speed, press the top of the switch.

To decrease speed, press bottom of the switch. Speeds can be adjusted at any time, whether machine is moving or not.

Basic: The position of the switch indicates speed setting.

Deluxe: The display indicates speed setting. When the key is turned on the controller will automatically adjust the speed to setting 2.

7. DRIVE RESET SWITCH

This safety feature is designed to ensure safe engagement of propel drive. Each time the machine power is turned on, and each time an operator steps on to the platform, the Drive Reset Switch must be pushed before machine will propel.

8. HORN BUTTON

The horn is activated by pressing the horn button.

9. STEERING WHEEL

The steering wheel turns the front wheel causing the machine to change direction.

10A. BATTERY CHARGE LEVEL INDICATOR-BASIC

Indicates the charge level of the batteries.

The meter display is divided into 10 vertical bars. Bars illuminated on the far right indicate full charge. Bars flashing near the left side indicate the batteries should be recharged. Further operation of the machine could damage the machine or the batteries.

When the machine is left overnight with less than a full charge, the display may initially indicate a full charge. It will also indicate a full charge if the batteries are disconnected, then reconnected. After a few minutes of operation the meter will give the correct charge level.

10B. BATTERY CHARGE LEVEL INDICATOR-DELUXE

The battery meter can be viewed at the left side of either information screen 1 or information screen 2. The level of battery charge is indicated by the horizontal bars in the battery meter box. When the batteries require charging, the icon will flash and a battery inhibit icon will appear on the right side of either information screen. Scrub and solution functions that are running when the battery inhibit icon appears will be automatically shut off. It is not possible to restart scrub functions while the battery inhibit is displayed. The controller reserves enough battery charge to allow pick-up of residual water and transport back to a charging station.



11A. HOUR METER-BASIC

Records the number of hours the machine has been in operation. This information is useful in determining when to service the machine.

11B. HOUR METER-DELUXE

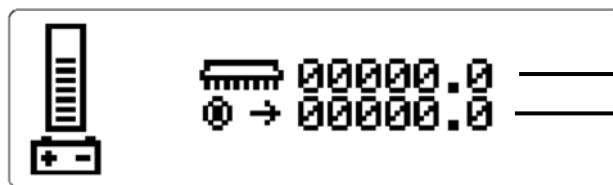

Brush Run Time:
Records the time spent with the brushes running and gives true brush motor time.

Traction Motor Time:
Records the time spent propelling the machine and gives true traction motor time.

SCRUB CONTROLS-BASIC AND CYLINDRICAL

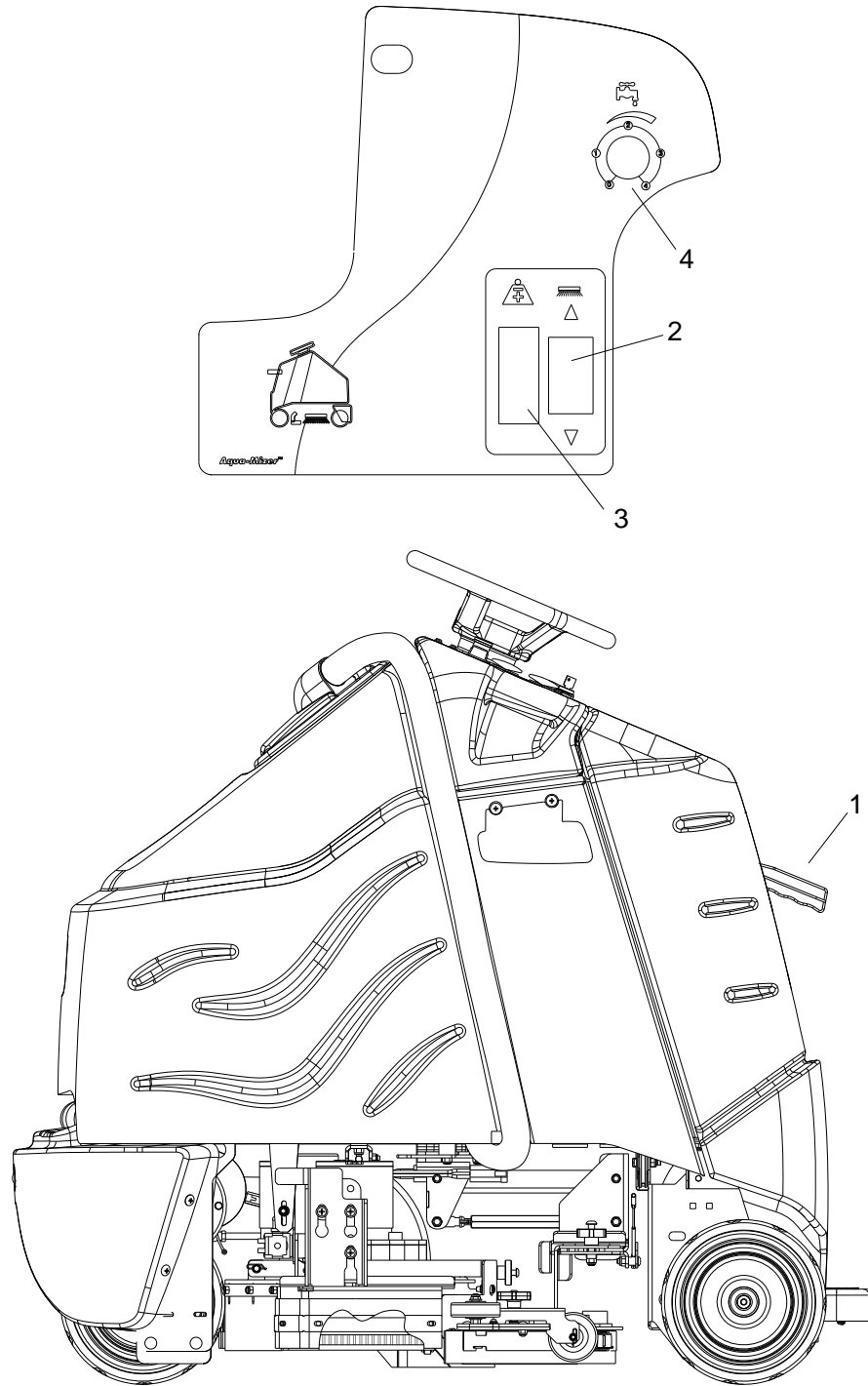

-
- | | |
|-------------------------------|-----------------------------|
| 1. Squeegee Lift Lever | 3. Brush Pressure Indicator |
| 2. Scrub Deck Actuator Switch | 4. Solution Control Knob |

SCRUB CONTROLS-BASIC-CYLINDRICAL

1. SQUEEGEE LIFT LEVER

Raises and lowers the squeegee, and turns the vacuum motor on and off.

To lower squeegee and start vacuum motor, lift the lever from its raised position.

To raise squeegee and stop vacuum motor, lift the lever from its lowered position.

2. ACTUATOR SWITCH

Raises and lowers the scrub deck, turns the scrub brush motors on and off, and adjusts the amount of brush/pad pressure to the floor.

To lower the scrub deck, turn on scrub brush motors, and/or increase brush pressure, press the bottom of the switch.

To raise the scrub deck, turn off scrub brush motors, and/or decrease brush pressure, press the top of the switch.

3. BRUSH PRESSURE INDICATOR

The brush pressure indicator corresponds to the amp draw of the scrub brush motors to tell how hard the motors are working. The blue zone indicates medium or proper brush pressure. The red zone indicates heavy or excessive brush pressure. Operating in the red zone may cause the brush circuit breakers to trip.

4. SOLUTION CONTROL KNOB

Controls solution flow to scrub deck

To increase flow, rotate knob clockwise.

To decrease flow, rotate knob counterclockwise.

If the brush motors are turned off or the throttle pedal is in neutral, the flow is automatically interrupted until the motors are turned on again. This feature prevents unintentional draining of the solution tank and allows the operator to adjust the solution flow to the scrub deck without resetting each time the scrubbing operation is interrupted.

SCRUB CONTROLS-DELUXE

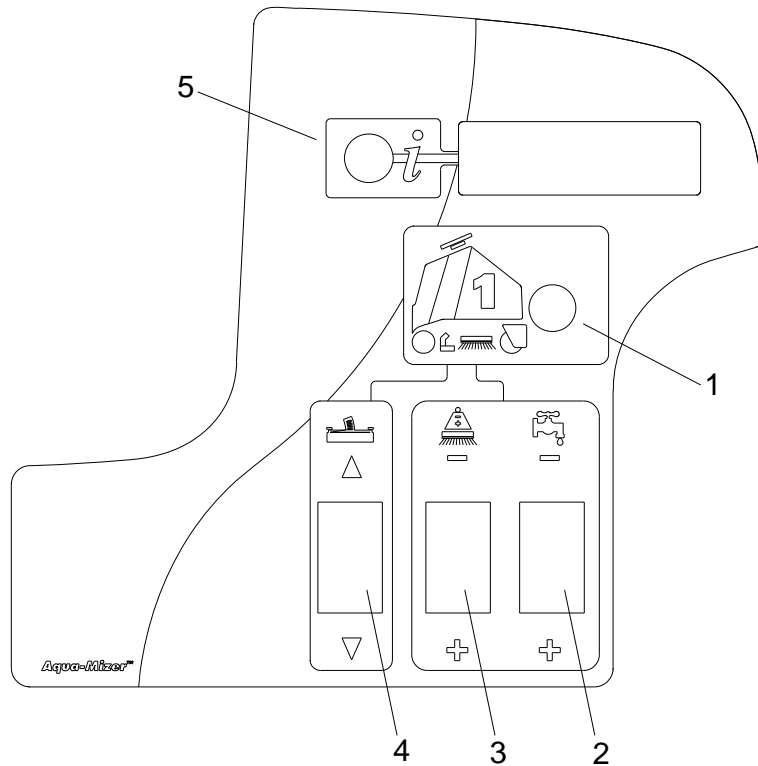

-
1. *One Touch Switch*
 2. *Solution Control Switch*
 3. *Brush Pressure Switch*
 4. *Vacuum/Squeegee Switch*
 5. *Display Toggle Switch*

1. ONE TOUCH SWITCH

This switch controls the scrub brushes and vacuum all in one touch.

To start scrubbing, press the one touch switch. The brush drive motors will turn on, the scrub deck will lower to the "light scrub" position, the solution will flow at "one bar" rate, the squeegee will lower and the vacuum will turn on. The information display window will show which functions are operating. If the throttle pedal is in the neutral position for more than two seconds the brushes and solution flow will stop. If the one touch switch is activated without brushes installed, the brush motors will stop, the scrub deck will rise, and the brush pressure indicator will display error code 9000.

To stop scrubbing, press the one touch switch. The brush drive motors will turn off, the scrub deck will raise the solution flow will stop, the squeegee will raise after a 15 second delay, and the vacuum motor will turn off. This delay is to clear the vacuum hose of recovered solution.

2. SOLUTION CONTROL SWITCH

This switch controls the amount of solution flow to the scrub deck. The information screen will show the solution setting. There are 4 different flow settings.

To increase the solution flow, press the bottom of the solution control switch (+).

To decrease solution flow, press the top of the switch (-).

If the brush motors are turned off or the throttle pedal is in neutral, the flow is automatically interrupted until the motors are turned on again, or the throttle pedal is pressed down. This feature prevents unintentional draining of the solution tank and allows the operator to adjust the solution flow to the scrub deck without resetting each time the scrubbing operation is interrupted.

3. BRUSH PRESSURE SWITCH

This switch controls the amount of brush pressure to the floor. The information display screen will show the amount of pressure. There are 4 different pressure settings.

To decrease the amount of down pressure, press the top of the brush pressure switch (-).

To increase the amount of down pressure, press the bottom of the brush pressure switch (+).

4. VACUUM/SQUEEGEE SWITCH

This switch independently controls the vacuum motor and squeegee position.

To start the vacuum motor and lower the squeegee to the floor, press the bottom of the switch.

To raise the squeegee and turn off the vacuum motor, press the top of the switch. The squeegee will raise after a 15 second delay, and the vacuum motor will turn off 15 seconds later, in order to clear vacuum hose of recovered solution.

5. DISPLAY TOGGLE SWITCH

The display toggle switch allows you to change the information displayed screen. Two screens are available.

Screen 1 displays battery charge level, speed setting, brush pressure setting and solution flow setting, as well as animated scrub brush and vacuum icons when these functions are engaged.

Screen 2 displays battery charge level and hour meters. Hours are displayed for brush run time and traction motor time.

SCRUB CONTROLS-SQUEEGEE

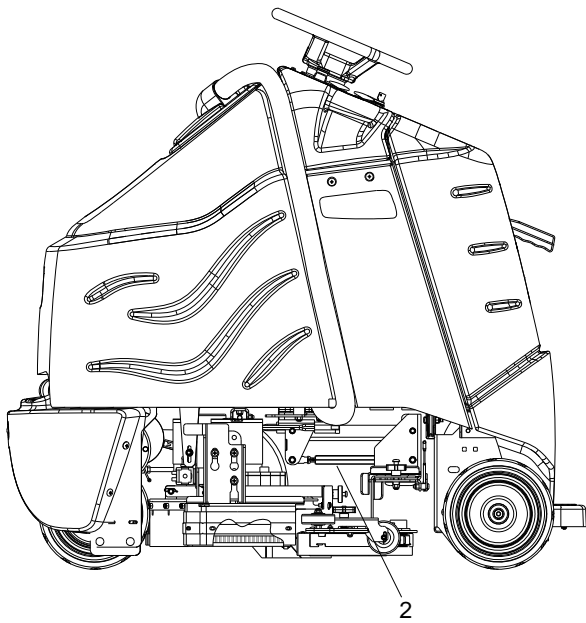
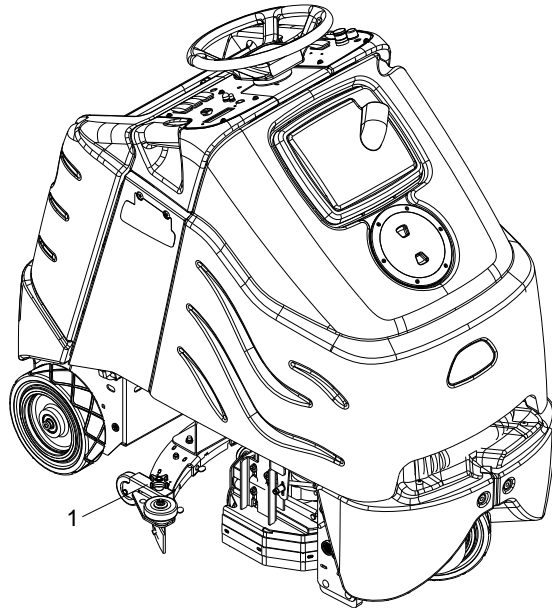

DISK SCRUBBER

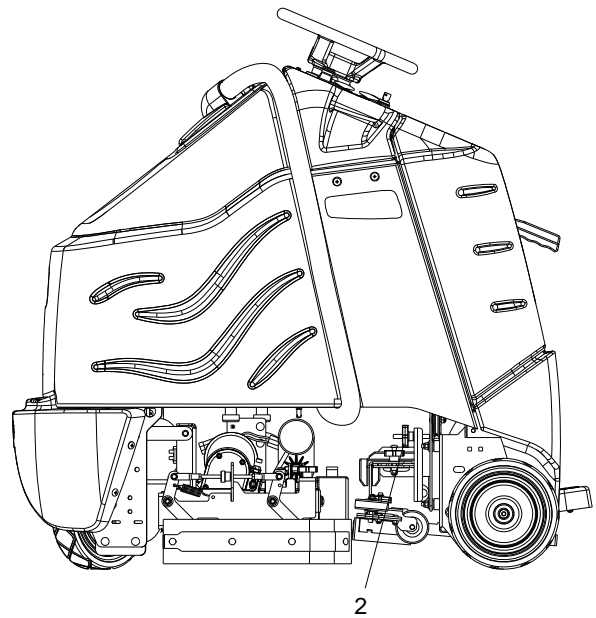

CYLINDRICAL SCRUBBER

1. Squeegee Deflection Adjustment Knobs

2. Squeegee Pitch Adjustment Rod

1. SQUEEGEE DEFLECTION ADJUSTMENT KNOBS

Adjusts the deflection along the entire length of the squeegee.

To increase squeegee blade deflection, turn the two knobs at the ends of the squeegee counterclockwise.

To decrease squeegee deflection, turn the two knobs at the ends of the squeegee clockwise.

2. SQUEEGEE PITCH ADJUSTMENT ROD (DISK SCRUBBER)

Adjusts the deflection at the ends of the squeegee.

To increase squeegee blade deflection at the ends, turn rod counterclockwise.

To decrease squeegee blade deflection at the ends, turn rod clockwise.

SQUEEGEE PITCH ADJUSTMENT KNOB (CYLINDRICAL)

Adjusts the deflection at the ends of the squeegee.

To increase squeegee blade deflection at the ends, turn knob counterclockwise.

To decrease squeegee blade deflection at the ends, turn knob clockwise.

MACHINE OPERATION

PRE-RUN MACHINE INSPECTION

Do a pre-run inspection to find possible problems that could cause poor performance or lost time from breakdown. Follow the same procedure each time to avoid missing steps.

NOTE: See maintenance section for pre-run machine inspection checklist items.

STARTING MACHINE

NOTE: Perform pre-run machine check before operating machine.

FOR SAFETY: Before starting machine, make sure that all safety devices are in place and operating properly.

1. The operator should be on the pedal platform with their left foot on the operator presence pedal. The throttle pedal must be in the neutral position.
2. Turn the machine power on by turning key switch clockwise to the "ON" position.
3. Check the position of the Directional Control Switch to make sure the machine will travel in the direction intended.
4. Press the Drive Reset Switch.
5. Press lightly on the throttle pedal with right foot.

EMERGENCY STOP PROCEDURES

1. Release the throttle pedal by lifting right foot.
2. Turn machine power off with key switch, by turning key switch counterclockwise.
3. If an electrical problem is suspected, push in emergency stop button. This will also engage the parking brake and cause the machine to stop immediately.

MACHINE OPERATION

FILLING SOLUTION TANK

FOR SAFETY: Before leaving or servicing machine; stop on level surface, turn off machine and remove key.

1. Turn the machine power off.
2. Remove solution cover.
3. Fill the solution tank with clean water, leaving enough room for the required amount of cleaning solution. The solution tank capacity filled to fill inlet is 25 gallons (95 liters). The water must not be hotter than 140° F (60°C) to prevent damage to the tank.
4. Measure the chemical into the solution tank. Liquid chemicals should be added to the solution tank after filling with water. Dry chemicals should be thoroughly mixed before being added into solution tank. Commercially available, high alkaline floor cleaners, are suitable for use in the solution system.

NOTE: Read the chemical manufacturers recommended proportion instructions.

5. Replace solution tank cover.

⚠ WARNING: Flammable materials can cause an explosion or fire. Do not use flammable materials in the tanks.

NORMAL SCRUBBING

Plan the scrubbing pattern in advance. The longest track is around the perimeter of the area to be cleaned. For efficient operation, the runs should be the longest possible without turning, stopping, or raising or lowering scrub deck/squeegee.

In order to achieve the best possible results, the area which is to be cleaned should be swept before scrubbing. Large debris, strings and wire must be removed to prevent being caught in brushes or squeegee.

If the machine is allowed to stand in neutral with the scrub deck down for more than 2 seconds, the solutions flow stops and brush motors stop. If either forward or reverse travel is selected, the solution flow will continue in the same setting and the scrub brush motors will continue in their same setting once movement of machine begins. Overlap the brush path and avoid transporting over previously cleaned areas.

INEFFICIENT SCRUBBING PATH

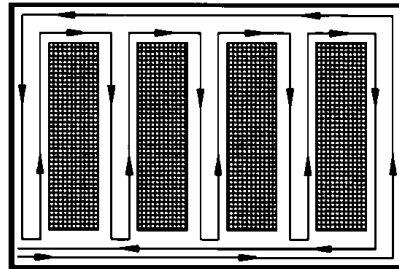

RECOMMENDED SCRUBBING PATH

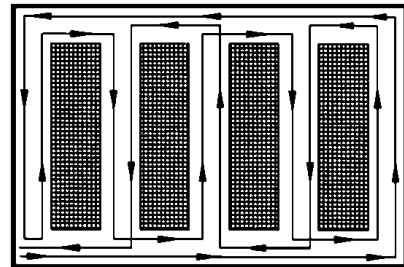

MACHINE OPERATION

TO BEGIN SCRUBBING

When operating the machine around people, pay close attention for unexpected movement. Use extra caution around children.

Flammable liquids and/or reactive metals can cause explosions or fire! Do not pick up.

1. Place left foot on operator presence pedal. Throttle pedal must be in neutral position.
2. Turn machine power on.
3. Check position of Directional Control Switch to ensure that machine is set to travel in direction intended.
4. Press the Drive Reset Switch.

5. BASIC AND CYLINDRICAL

Lower the squeegee.

Lower the scrub deck to floor.

DELUXE

Press the one-touch switch (#1) on the control panel. The brush motors will start, the scrub deck will lower to the light scrub position, the solution will begin to flow, the squeegee will lower to the floor and the vacuum motors will start.

6. Drive machine forward to begin scrubbing.

NOTE: Shut machine off immediately if water or foam is expelled from the machine.

7. Adjust the speed of the machine, solution flow and scrub brush pressure as necessary.

NOTE: Once solution flow rate is set it is not necessary to shut off solution when stopping scrubbing. Solution flow is automatically shut off when brush motors stop. When brush motors are activated, flow automatically resumes.

PRIMING PUMP

If the solution system has gone dry or has been unused for a period of time, it may be necessary to follow the pump priming procedure.

1. Fill solution tank.
2. Loosen, but do not completely remove the strainer bowl. Solution should flow out of the strainer. If it does not, check the strainer screen inside the solution tank. Insure it is clear of debris. Tighten the strainer bowl.
3. Disconnect the squeegee hose from the recovery dome.
4. Begin normal scrubbing and set the solution flow to maximum setting. Solution flow should begin within 2 minutes.
5. Connect squeegee hose to recovery dome.
6. Adjust the speed of the machine, solution flow and scrub brush pressure as necessary.

TO STOP SCRUBBING

1. BASIC AND CYLINDRICAL

Raise the scrub deck, turn off scrub brushes.

Raise squeegee, turn off vacuum.

DELUXE

Press the one-touch switch (#1) on the control panel. The brush motors will stop and the scrub deck will rise to the park position. After 15 seconds the squeegee will raise, and 15 seconds later the vacuum motor will turn off. This delay is to clear the vacuum hose of recovered solution.

2. Allow the throttle pedal to return to neutral.
3. Turn machine power off.

FOR SAFETY: Before leaving or servicing machine: stop on level surface, turn off machine and remove key.

DOUBLE SCRUB

For floors which are heavily soiled or have thick accumulations of floor finish may not clean sufficiently with one pass. In these cases it will be necessary to double scrub.

To double scrub, make the first pass over the surface being cleaned with the squeegee up, vacuum off, the solution on, Aqua-Mizer removed and brushes down. This allows the solution to stay in contact with the soil while loosening the surface accumulation with the brushes. Allow time for the first application to stay in contact with the floor. Length of time between the first and second pass depends on amount of accumulation and the type of chemical being used. A second scrubbing with the squeegee down and again the solution and brushes on will further loosen soil. The additional application of solution will further assist the difficult cleaning job.

FOR SAFETY: When using machine, go slow on inclines and slippery services.

MACHINE OPERATION

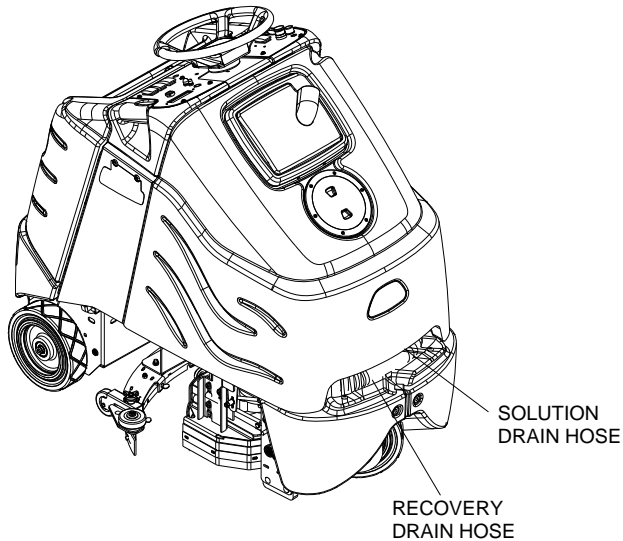

EMPTYING AND CLEANING TANKS

1. Park the machine next to a floor drain. Drain hoses are at the front of the machine.
2. Turn the machine power off.

RECOVERY TANK

1. Pull the large drain hose from under the front of the tank. Unscrew cap, then lower hose in direction of the drain. Do not stand in front of end of hose. Recovered solution will come out with force.
2. Remove the recovery tank dome. Flush the recovery bag out with clean water. Do not use water hotter than 140°F (60°C) to clean tank. Damage may occur.
3. Clean debris from dome basket.
4. Clean off the float shut-off system and inspect for free movement of float. The float shut-off system is located in the rear of the recovery tank.
5. Replace the drain cap and secure drain hose under tank.
6. If machine is to be stored, leave the recovery tank dome off.

SOLUTION TANK

1. Pull recovery drain hose out to expose the solution drain hose.
2. Pull the solution drain hose from under front of the tank. Unscrew the T-handle on plug enough to loosen plug, then lower hose in direction of drain. Slowly remove plug from drain hose.
3. Remove the solution tank cover.
4. Flush the solution tank out with clean water and run several gallons of clean water through systems. Do not use water hotter than 140°F (60°C) to clean tank. Damage may occur.

NOTE: Never allow solution to remain in tank. Damage to tank, seals and valves could occur.

Tuck drain hose under tank and secure with recovery drain hose by tucking it under tank.

NOTES:

MAINTENANCE

SERVICE SCHEDULE

MAINTENANCE	BEFORE EACH WORK PERIOD	AFTER EACH WORK PERIOD	50 HRS	100 HRS	200 HRS
Check water level of batteries after charging; add distilled water if necessary. (Wet cell only)	*				
Check that dome and cover seal tightly.	*				
Visually check for damaged or worn tires.	*				
Check brushes or pads for proper installation.	*				
Check vacuum hose connections.	*				
Check that squeegee is securely attached and properly adjusted.	*				
Check for securely attached drain hoses, plug and cap.	*				
Check both pedals, brake and steering for proper operation.	*				
Clean out recovery tank and dome basket.		*			
Clean and inspect float shutoff.		*			
Clean out solution tank and filter, check flow.		*			
Clean and inspect solution filter strainer.		*			
Run vacuum motors to dry.		*			
Clean brushes or pads and check wear.		*			
Clean squeegee blades and check wear.		*			
Clean outside of tanks, check for damage.		*			
Store with dome off tank.		*			
Charge batteries.		*			
Clean off top of batteries.			*		
Check battery cells with hydrometer. (Wet cell only)			*		
Inspect scrub deck skirts and Aqua-Mizers.			*		
Clean solution strainer inside tank.			*		
Check battery connections are tight.			*		
Clean battery cases and battery compartment.				*	
Clean and check drive tension chain for wear and tension.				*	
Check parking brake.					*
Clean chains, cables and pulleys for squeegee lift.					*
Clean pivot points on squeegee and scrub deck.					*
Check all motors for carbon brush wear.					*
Check motor commutators.					*
Check steering chain tensioner.					*

NOTE: Traction drive, wheels and batteries should be serviced based on traction drive hour meter (Deluxe). The scrub brush hour meter should be used for all other service schedule items.

MAINTENANCE-BATTERIES

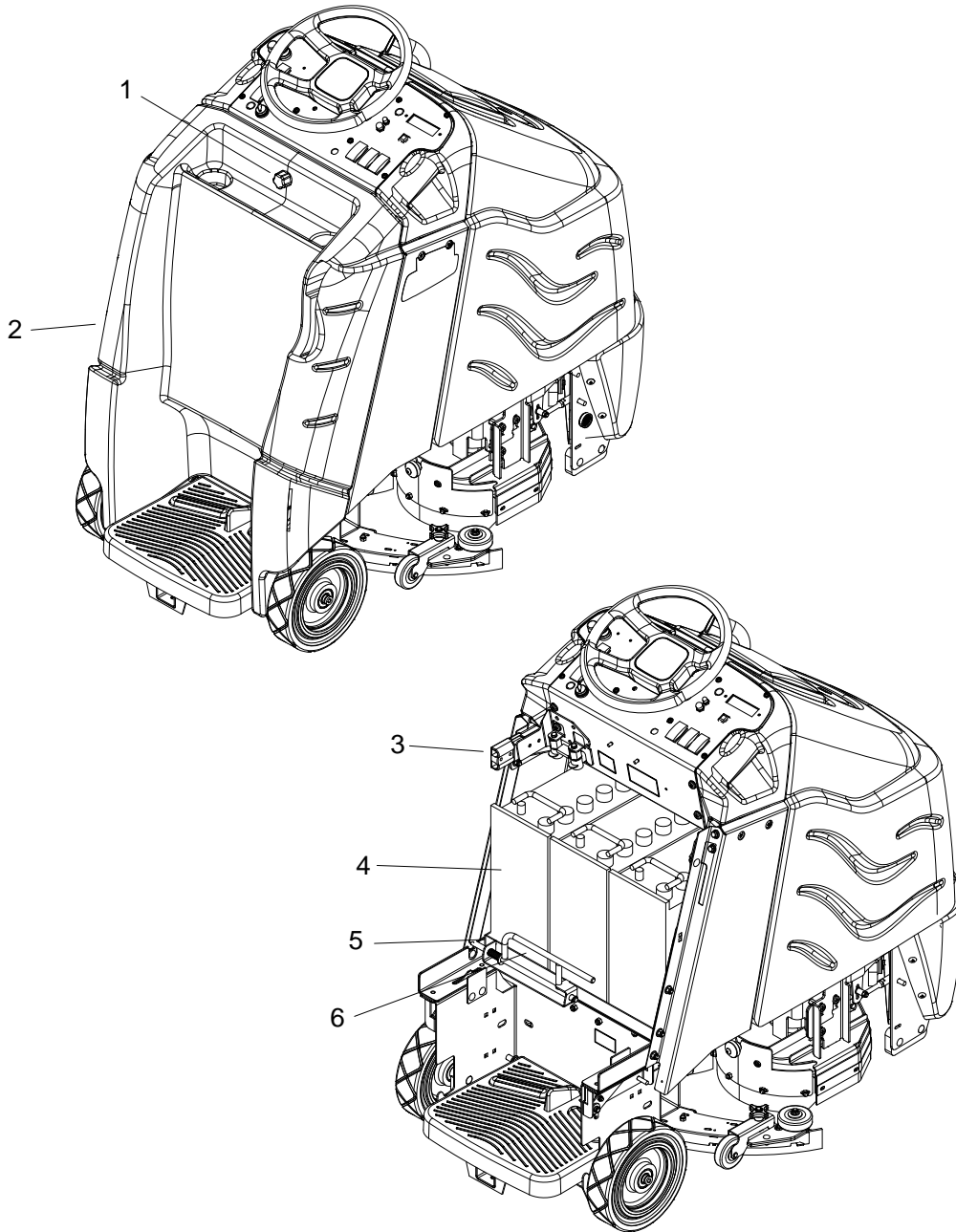

-
- | | | | |
|----|----------------------------------|----|---------------------------|
| 1. | <i>Rear Cover Retainer Knob</i> | 4. | <i>Batteries</i> |
| 2. | <i>Rear Cover</i> | 5. | <i>Battery Tray</i> |
| 3. | <i>Battery Connector-Machine</i> | 6. | <i>Battery Tray Latch</i> |

MAINTENANCE-BATTERIES

BATTERIES (WET CELL ONLY)

The batteries provide the power to operate the machine. The batteries require regular maintenance to keep them operating at peak efficiency.

The machine batteries will hold their charge for long periods of time, but they can only be charged a certain number of times. To get the greatest life from the batteries, charge them when their charge level reaches 25% of a full charge. Use a hydrometer to check the charge level.

Do not allow the batteries to remain in a discharged condition for any length of time. Never expose a discharged battery to temperatures below freezing. Discharged batteries will freeze causing cracked cases. Do not operate the machine if the batteries are in poor condition or if they have a charge level below 25% (specific gravity below 1.155).

Keep all metallic objects off the top of the batteries, as they may cause a short circuit. Replace worn or damaged cables and terminals.

Check the electrolyte level in each battery cell before and after charging the batteries. Never add acid to the batteries, use distilled water. Do not allow water level to fall below the battery plates. Portions of plates exposed to air will be destroyed. Do not overfill. Keep plugs firmly in place at all times.



CAUTION: When servicing machine, avoid contact with battery acid.



WARNING: Batteries emit hydrogen gas. Explosion or fire can result. Keep sparks and open flame away. Keep covers open when charging.



WARNING: Wear eye protection and protective clothing when working with batteries.



WARNING: Charge batteries in a well ventilated area.

BATTERY MAINTENANCE

1. When cleaning the batteries, use a solution of baking soda and water. Do not allow the cleaning fluid to enter the battery cells, electrolyte will be neutralized.
2. Maintain the proper electrolyte level in each battery cell. If a cell should accidentally overflow, clean immediately.
3. Wipe off the top of the batteries at least once a week.
4. Test battery condition with a hydrometer at least once a week.
5. Ensure that all connections are tight and all corrosion removed.
6. Every 4 to 6 months, remove that batteries from the machine and clean the battery cases and battery compartment.

CHECKING BATTERY SPECIFIC GRAVITY

Use a hydrometer to check the battery specific gravity.

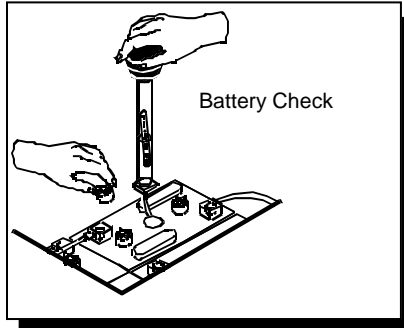

CHECKING GRAVITY

- A. Hydrometer
- B. Battery

NOTE: Do not take readings immediately after adding distilled water, if the water and acid are not thoroughly mixed, the reading may not be accurate.

Check the hydrometer readings against this chart.

SPECIFIC GRAVITY @ 80° F (27°C)	BATTERY CONDITION
1.265	100% CHARGED
1.225	75% CHARGED
1.190	50% CHARGED
1.155	25% CHARGED
1.120	DISCHARGED

NOTE: If the readings are taken when the battery electrolyte is any temperature other than 80° F (27°C), the reading must be temperature corrected.

To find the corrected specific gravity reading when the temperature of the battery electrolyte is other than 80° F (27°): Add (+) to the specific gravity reading 0.004 (4 points), for each 10° F (6° C) above 80° (27° C).

Subtract (-) from the specific reading 0.004 (4 points), for each 10° F (6° C) below 80° F (27° C).

CHARGING BATTERIES

CAUTION: When servicing machine, avoid contact with battery acid.

WARNING: Batteries emit hydrogen gas. Explosion or fire can result. Keep sparks and open flame away. Keep covers open when charging.

WARNING: Wear eye protection and protective clothing when working with batteries.

WARNING: Charge batteries in a well ventilated area.

Use a 36 volt, 20 amp maximum output DC charger which will automatically shut off when the batteries are fully charged.

1. Stop the machine in a clean, well ventilated area next to the charger.
2. Turn "OFF" machine.

FOR SAFETY: Before leaving or servicing machine; stop on level surface, turn off machine and remove key.

3. Remove rear cover, unplug batteries from machine, unlatch battery tray and pull out to expose batteries.

WARNING: Batteries emit hydrogen gas. Explosion or fire can result. Keep sparks and open flame away. Keep covers open when charging.

4. Check the electrolyte level in each battery cell. Before charging, add just enough distilled water to cover the plates. After charging is complete, add just enough distilled water to bring up the level to the indicator ring. If the water level is too high before charging, normal expansion rate of the electrolyte may cause an overflow resulting in a loss of battery acid balance and damage the machine.

MAINTENANCE-BATTERIES

5. Replace the battery caps, and leave them in place while charging.
6. Unplug the battery connector from the machine.

FOR SAFETY: When charging, connect the charger to the batteries before connecting the charger to the AC wall outlet. Never connect the charger to the AC wall outlet first. Hazardous sparks may result.

7. Plug the charger connector into the battery connector. Connect the charger AC plug to a wall outlet. The charger gauge should indicate that the batteries are charging.
8. When the batteries are fully charged, disconnect the charger from the AC wall outlet, then disconnect the charger from the batteries.
9. Connect the batteries to the machine connector.
10. Check the electrolyte level. It should be up to the indicator ring. If necessary, add distilled water.
11. Install the rear cover.

CHANGING BATTERIES

Stop the machine in a clean area next to the charger. Turn off machine.

FOR SAFETY: Before leaving or servicing the machine; stop on level surface, turn off machine and remove key.

1. Remove the rear cover.
2. Disconnect battery pack from machine.
3. Unlatch battery tray from machine and pull out to expose batteries.
4. Use the proper size open end wrench to disconnect main ground wire first and secure cable terminal away from batteries.
5. Disconnect main positive lead and secure cable terminals away from batteries.
6. Loosen both terminals on each jumper cable and remove one at a time.
7. Prepare a suitable site to place the batteries.



WARNING: Attach suitable battery lifting device and lift batteries from the machine.

Batteries are a potential environmental hazard. Consult your battery supplier for safe disposal methods.

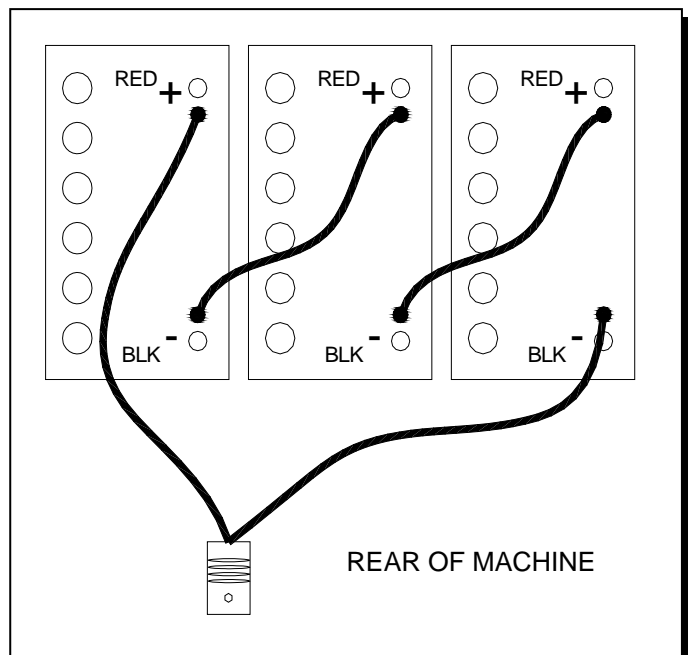

MAINTENANCE-SQUEEGEE

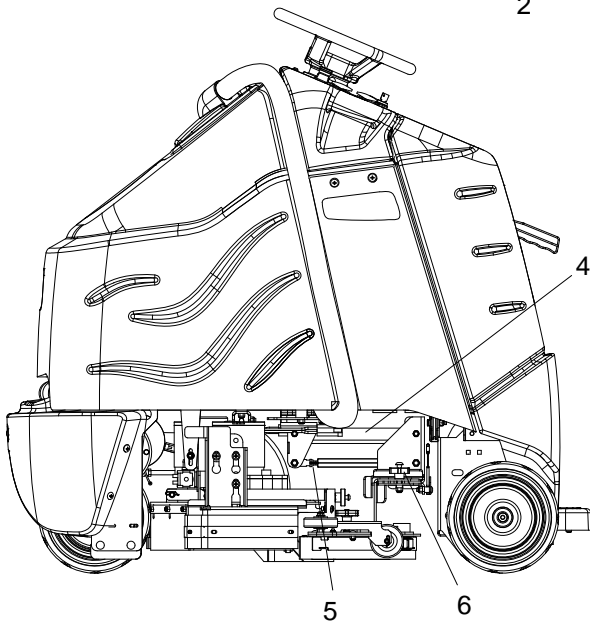
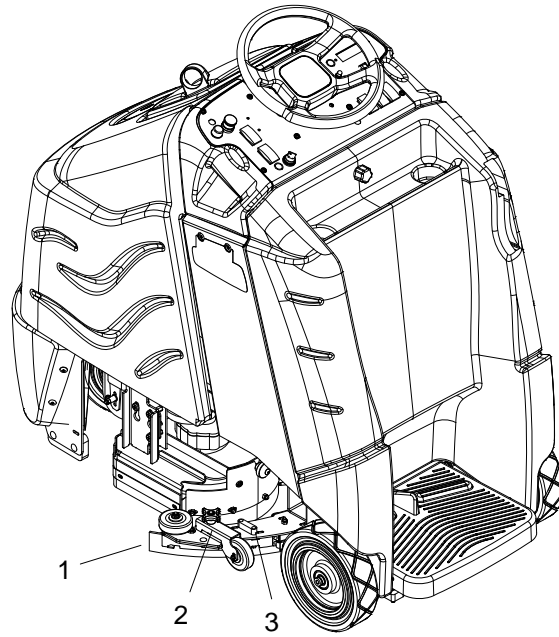

DISK SCRUBBER

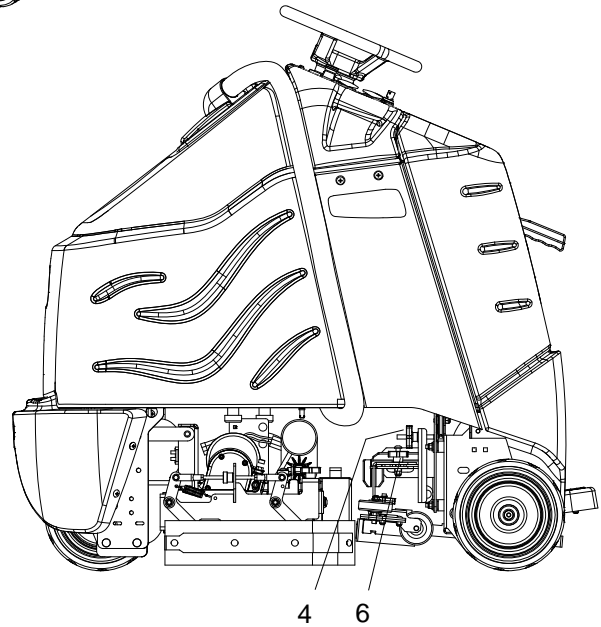

CYLINDRICAL SCRUBBER

-
- | | | | |
|----|---|----|---|
| 1. | <i>Squeegee</i> | 4. | <i>Squeegee Pitch Adjustment Rod/Cylindrical Knob</i> |
| 2. | <i>Squeegee Deflection Adjustment Knobs</i> | 5. | <i>Squeegee Pitch Adjustment Lock Nut</i> |
| 3. | <i>Squeegee Level Indicator</i> | 6. | <i>Squeegee Retainer Knob</i> |

MAINTENANCE-SQUEEGEE

SQUEEGEE BLADES

The front squeegee blade allows solution to pass through channels in the blade into the squeegee assembly while maintaining vacuum to provide lift. The front blade has four wear surfaces and can be rotated for extended life. The front blade should not require regular replacement under normal use.

The rear blade wipes the floor to a near dry condition. It is important the rear blade be in good condition to properly do its job. As with the front, each squeegee blade assembly has four wear surfaces for extended service.

Check both the front and rear squeegee blades for damage, wear, and adjustment each day in the pre-run check. Change the front blade if it is torn or has an uneven edge. Change the rear blade if it is less than 1/2 the original thickness.

ADJUSTING SQUEEGEE

Adjusting the squeegee is a two-part process. First, the squeegee assembly must have correct pitch in order for the squeegee blade to have the same deflection at each tip as well as the center. The rod on the squeegee linkage controls the pitch adjustment. The second adjustment is the deflection. Knobs on each end of the squeegee control this.

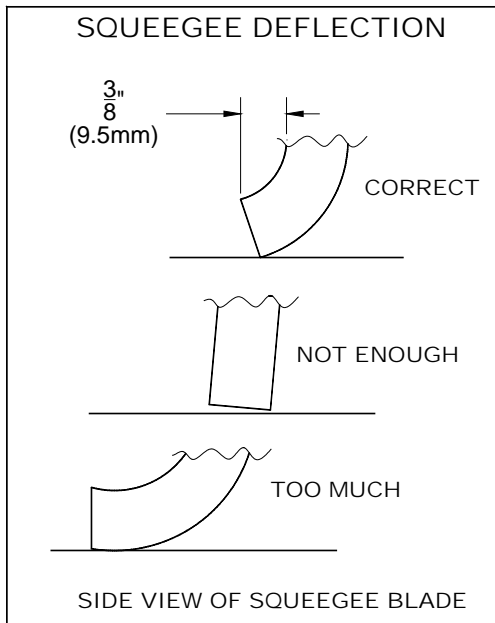

TO REMOVE SQUEEGEE ASSEMBLY

1. With the squeegee in the up position, turn key switch "OFF".
2. Disconnect vacuum hose from squeegee and loosen knob on left side of squeegee lifting carrier.
3. Pull squeegee assembly from the lifting carrier.
4. Inspect or repair as necessary and reinstall.

TO REPLACE OR ROTATE REAR SQUEEGEE BLADES

1. With the squeegee in the up position, turn key switch "OFF".

FOR SAFETY: Before leaving or servicing machine; stop on level surface, turn off machine and remove key.

2. Remove the squeegee assembly from the machine. Unlatch and remove blade retainer strap and remove squeegee blade.
3. Rotate the squeegee to new edge position or replace as required. Each blade has four new edge positions.
4. Install blade on locating pins of squeegee assembly.
5. Install squeegee retainer strap.
6. Fasten and lock latch, adjust latch only tight enough to take up slack in retaining strap.

TO REPLACE OR ROTATE FRONT SQUEEGEE BLADE

1. With the squeegee in the up position, turn key switch "OFF".
2. Remove the squeegee from the machine. Loosen thumbscrews and remove the retainer strap and squeegee blade.
3. Rotate the squeegee to new edge position or replace as required. Each blade has four new edge positions. When installing the front blade, tighten the center thumbscrew first. Insure that the retainer strap is pressed against the blade before tightening the outer screws.

MAINTENANCE-SQUEEGEE

TO ADJUST SQUEEGEE PITCH

1. Choose a smooth, level surface. Turn "ON" the key switch. Lower the squeegee and drive forward at least 2 feet (60cm.).
2. With the squeegee down, stop the machine. Do not allow machine to roll back.

FOR SAFETY: Before leaving or servicing the machine; stop on level surface, turn off machine and remove key.

3. Determine the differences, if any, in deflection of the squeegee blade between each end and the middle. Proper adjustment is obtained when deflection is equal all the way across the squeegee blade. The bubble level should also indicate when the squeegee is adjusted properly. When the air bubble is in the center of the vial, the deflection should be even across the squeegee blade.
4. To decrease the deflection of the squeegee blade at the ends, loosen wing nut and rotate the rod clockwise. To increase the deflection at the ends of the squeegee assembly, rotate the rod counterclockwise knob.
5. Check the deflection of the squeegee blades again. Repeat steps 1 through 4 until the deflection is equal across the entire rear squeegee blade. Tighten wing nut.

TO ADJUST AMOUNT OF REAR SQUEEGEE DEFLECTION

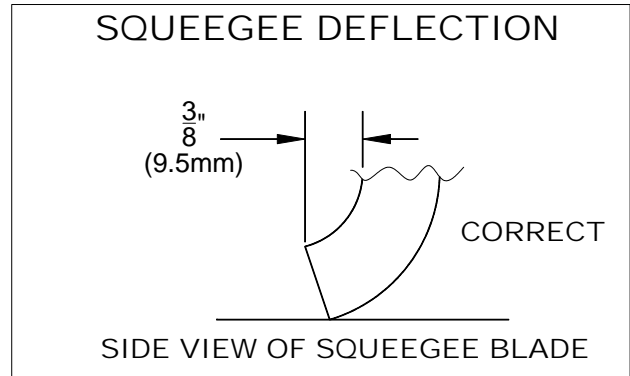

1. Choose a smooth, level surface. Lower the squeegee and drive forward at least 2 feet (60cm).
2. With the squeegee down, stop the machine. Do not allow machine to roll back.

FOR SAFETY: Before leaving or servicing machine; stop on level surface, turn off machine and remove key.

3. Observe the amount of squeegee deflection. It should deflect 3/8 in. (9.5mm) across the entire width of the squeegee.
4. To increase the squeegee deflection, turn the 2 knobs at the squeegee ends counter-clockwise. To decrease the deflection, turn the knobs clockwise.

NOTE: The deflection should be consistent along the length of the squeegee. If the deflection varies from end to end the knobs can be adjusted independently to correct the variation.

5. Turn on the key switch. Raise, then lower squeegee assembly. Drive forward at least 2 feet (60cm).
6. Repeat steps 2 through 4 until deflection of 3/8 in. (9.5mm) is reached.

MAINTENANCE-SCRUB BRUSHES

SCRUB BRUSHES

There are four different types of brushes available to cover applications from cleaning heavily soiled floors to polishing. A pad driver is also available to take advantage of the many cleaning pads on the market. Please refer to the following to assist in selecting the proper brush or pad for the work at hand.

UNCOATED FLOORS

Aggressive Grit is a nylon fiber impregnated with silicone carbide grit. It grinds away stain, soil, and removes surface material.

Mild Grit is a less aggressive silicone carbide grit suitable for cleaning medium soil conditions. Advantages are faster ground speed than nylon bristles on light solid applications.

Polypropylene is a general-purpose scrub brush with stiff bristles. Polypropylene works well for maintaining concrete, wood and tile floors.

FINISHED FLOORS

Nylon bristles are used in a variety of applications on coated or uncoated surfaces.

White Pads (Polishing) are used for dry polishing to achieve a high-gloss appearance, or surface washing on highly polished or burnished floors.

Red Pads (Buffing) are used for light-duty scrubbing. When used with a mild detergent they will provide surface cleaning without removing the finish.

Blue Pads (Scrubbing) are used for heavy-duty scrubbing and light stripping. The blue pads remove less finish than brown stripping pads, yet will remove black marks, stains and dirt.

Black Pads (Stripping) are used for easy and complete removal of old floor waxes/finishes. They will quickly remove ground in dirt, black heel marks, and spills. When used with the proper stripper, this pad leaves the floor clean and ready for finishing.

The scrub brushes should be checked before each days work for wire, string, wear and damage.

MAINTENANCE-SCRUB DECK – DISK

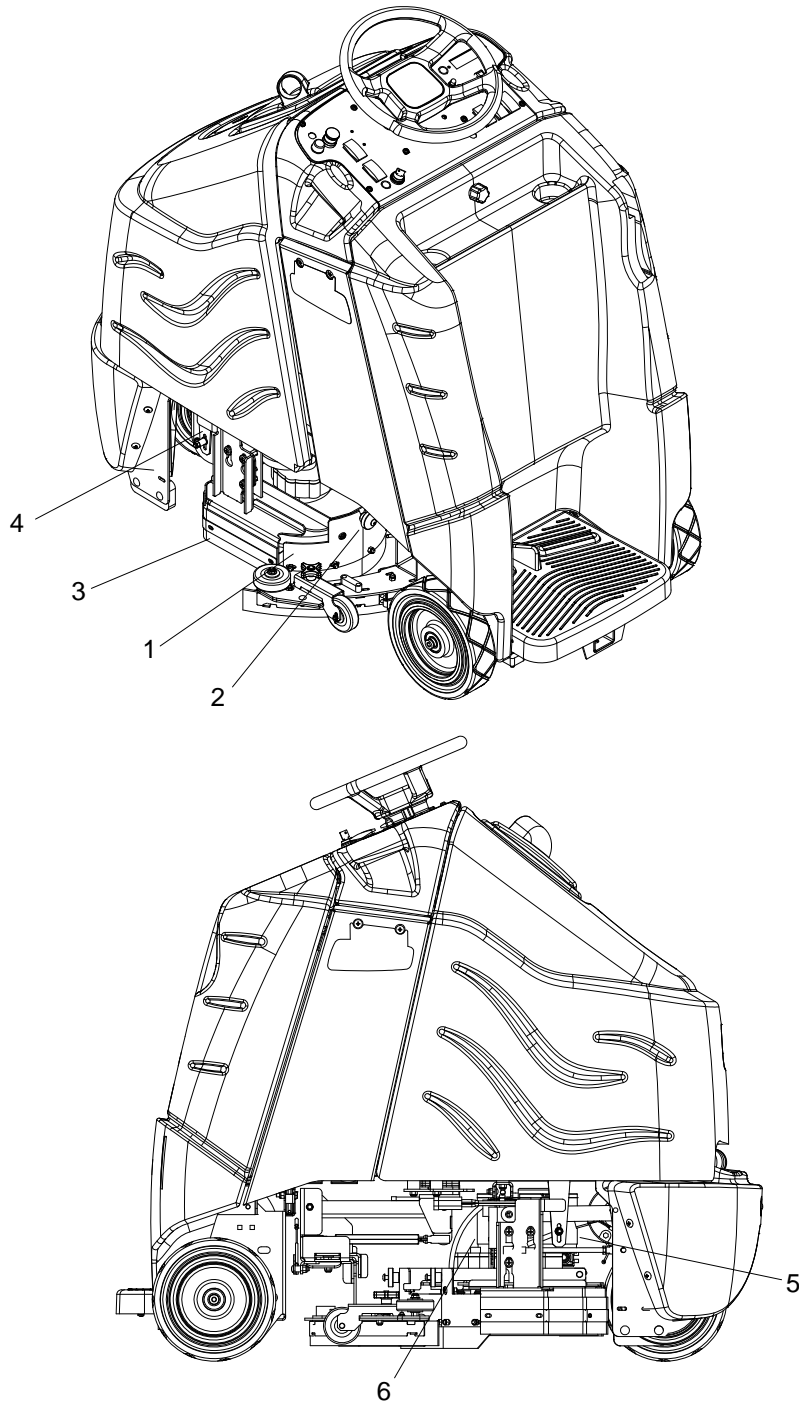

-
- | | |
|------------------------------|-----------------------------|
| 1. Scrub deck Aqua-Mizer™ | 4. Scrub deck skirt stop |
| 2. Aqua-Mizer™ retainer knob | 5. Scrub brush motor |
| 3. Scrub deck skirt | 6. Scrub deck lift actuator |

MAINTENANCE-SCRUB DECK - DISK

⚠ WARNING: *Do not use a pressure washer to clean around the brush motors. Use tap pressure only.*

TO REPLACE SCRUB BRUSH MOTORS

1. With the scrub deck in the raised position, disconnect brush motor wiring connector from harness.
2. Remove skirts from scrub deck to access and remove scrub brushes or pad drivers.
3. Remove Aqua-Mizers™ from scrub deck.
4. Remove retaining bolt, lock washer, flat washer and star drive from brush motor shaft.
5. Remove 4 brush motor mounting bolts located under scrub deck.
6. Lower scrub deck.
7. Remove brush motor.
8. Reverse steps to install.

BRUSH MOTOR CARBON BRUSH REPLACEMENT

1. Scribe alignment mark on motor barrel to motor cap. Remove two bolts.
2. Remove end cap from motor.
NOTE: *Motors contain two wave washers in cap. Do not lose these.*
3. Release brush from spring tension. Remove screw connecting brush wire lead to brush holder. Clean brush holder to insure free movement.
4. Retract spring and install new brush. Install connector screw and lead.
5. When all new brushes are installed. Place all in retracted position, held into brush holder by spring tension.
6. Carefully place end cap onto bearing on motor shaft.
NOTE: Use care to assure wave washer alignment.
7. With end cap in partially installed position, release all brushes to contact position with motor commutator.

NOTE: Failure to insure all brushes are released will result in motor failure.
8. Reset end cap and realign with scribe marks on motor barrel. Reinstall the two attach bolts from cap into base.
9. Maintain alignment between motor barrel base and cap.

MAINTENANCE-SCRUB DECK - DISK

SCRUB DECK ACTUATOR ADJUSTMENT

FOR SAFETY: Before leaving or servicing machine, stop on a level surface. Turn off machine.

1. Remove the two screws that secure actuator spring plate and pull actuator barrel from stud on actuator spring bracket.
2. Remove clevis pin from upper bracket of actuator.
3. Disconnect actuator from wiring harness.
4. Reverse steps to install.

The actuator will need to be adjusted when replaced.

To adjust the actuator:

1. While holding actuator barrel to prevent it from spinning, apply power to the actuator such that it is fully extended. Positive power to white wire, and negative/ground to black. Limit switch within actuator will stop it.
2. Turn barrel out one or more full turns to assure that when it is retracted it will not bind against itself.
3. While holding actuator barrel to prevent it from spinning, apply power to the actuator such that it is fully retracted. Positive power to black wire, and negative/ground to white wire. Limit switch within actuator will stop it.
4. With actuator fully retracted, turn barrel in until it touches the base of the threaded shaft.
5. At the bottomed out position, turn the barrel out **1 full turn**, then enough more to allow connection to lift linkage.
6. Connect actuator to lift linkage.
7. Check travel of actuator during operation.

MAINTENANCE-SCRUB DECK - CYLINDRICAL

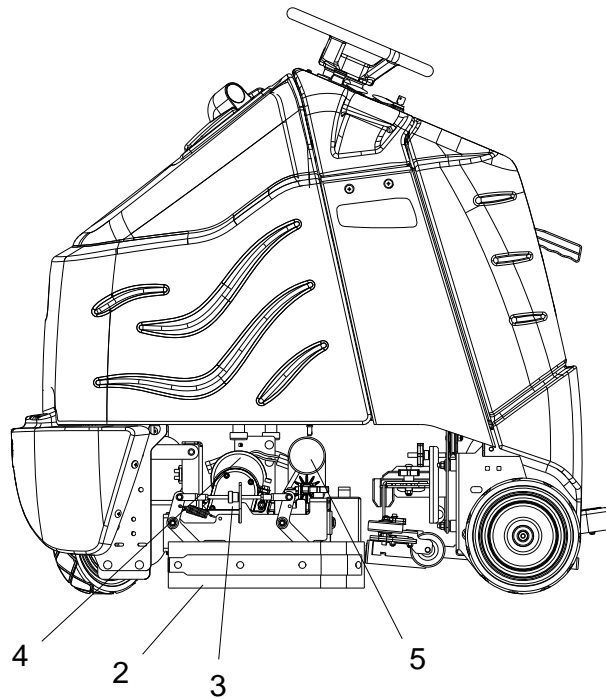
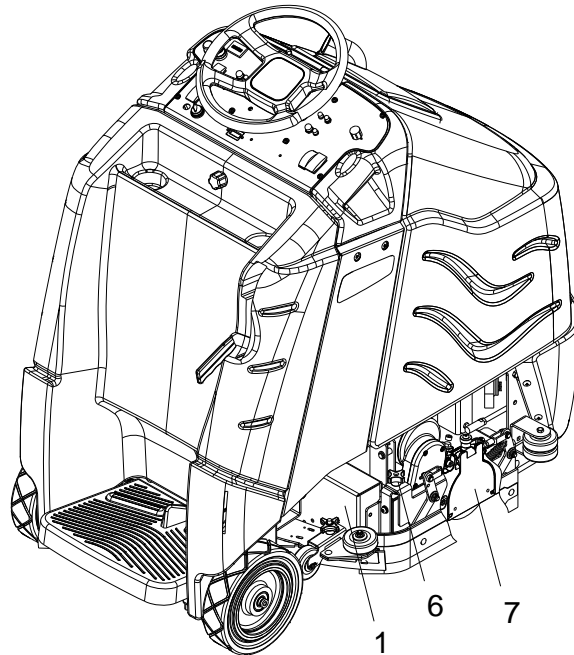

-
- | | |
|----------------------------------|-------------------------------|
| 1. Hopper | 5. Scrub deck lift actuator |
| 2. Blade side squeegee | 6. Side squeegee removal knob |
| 3. Side squeegee adjustment knob | 7. Brush door |
| 4. Scrub brush motor | |

MAINTENANCE-SCRUB DECK - CYLINDRICAL

SCRUB HEAD-CYLINDRICAL

The dual cylindrical scrub head is designed to eliminate debris that may be caught in the squeegee while scrubbing. Water is applied to the first scrubbing brush turning in a clockwise rotation when viewed from the right of operator's side of machine. The first brush scrubs dirt and debris between the brushes. The second scrubbing brush, turning in a counter clockwise rotation, picks up debris and throws it into a removable hopper. The larger debris which might catch under the squeegee is collected in the hopper. Water is allowed to drain out the hopper into the squeegee path where it is recovered from the floor.

MAINTENANCE

The brushes should wear evenly side to side if properly adjusted. Scrub brushes should be exchanged front to back every 50 hours to ensure even wear since the rear brush contacts the floor with more force. It is not necessary to rotate end for end since swapping front to back puts the brushes in the opposite rotation, as well as balancing wear. Scrub brushes should be replaced as a set when bristle length wears to height of yellow PerformAlert™ bristles.

SCRUB BRUSH REMOVAL

The scrub brushes are removed from the side of the machine. The front is removed from the right side and the rear is removed from the left side.

1. Unscrew the knob and swing side squeegee out about 90°
2. Unscrew knob on side door but do not remove.
3. Pull out on top of door until lip on door clears brush head.
4. Push down on door until hooks on bottom of door are free of scrub head side.
5. Pull out on door with a rocking motion to free idler door from end of brush.
6. Pull brush out with a rocking motion to free brush from drive hub.

SCRUB BRUSH REPLACEMENT

1. Unscrew the knob and swing side squeegee out about 90°
2. Lift the drive side of the brush. Push brush until a positive stop is felt. The idler plate cannot be installed until the brush is fully seated on the drive hub.
3. Allow brush to drop below scrub deck. Fully insert plate onto brush.
4. Line up bottom hook on idler door with notches on side of scrub head.
5. Slide idler door up until lip rests on top of scrub head.
6. Hand tighten knob to secure door into place.

TO ADJUST SCRUB DECK SIDE SQUEEGEES

These skirts should be adjusted to 3/8" deflection.

To adjust:

1. Lower scrub deck to floor.
2. Stop machine.
3. Loosen scrub deck skirt stop.
4. Adjust stop such that skirt deflection is about 3/8".

TO REPLACE SCRUB DECK SIDE SQUEEGEES

These skirts have four wear edges.

To use another edge:

1. Remove each of the scrub deck skirt assemblies.
2. Remove the hardware that retains the blade on each assembly.
3. Flip the blade vertically or horizontally, or both, and replace hardware.
4. Re-install each scrub deck assembly.

MAINTENANCE-SCRUB DECK - CYLINDRICAL

DUMPING HOPPER

The removable hopper is located behind the rear scrub brush. If the hopper becomes full, it will not accept any more debris. Loosen knob on left side squeegee and swing open. Remove the hopper by sliding it out from the operator's left side of the machine. The hopper can then be dumped from the top. Flush the hopper clean with running water.

SCRUB DECK ADJUSTMENT

Scrub deck adjustment consists of two types of adjustments. The first is to insure the individual brushes make the same width pattern end to end. Any tapered brush pattern should be adjusted out. The second is to make the pattern of equal width between front and rear brushes. Unequal patterns are caused by the scrub deck not being parallel to the floor. Proper adjustment is obtained when the contact patterns of the brushes on the floor show two 1" rectangles the width of the brushes. The rectangles should be parallel to each other.

TESTING, ADJUSTMENT OF INDIVIDUAL BRUSHES

1. Move the machine to an unfinished area of floor to avoid marking finish.
2. With water valve off, lower scrub head to floor. Allow brushes to run until automatic shut off occurs. It may be necessary to repeat this step in the same location until a good mark can be seen on the floor. This can be accomplished by touching lightly the throttle pedal to restart the scrub deck without moving the machine.
3. Raise the scrub deck and note the brush patterns on the floor. There should be two rectangles with parallel sides. If the pattern is tapered, proceed as follows.

ADJUSTMENT OF INDIVIDUAL BRUSHES

The brush pattern is adjusted from the motor side only of both brushes.

1. Determine if motor end is to be moved up or down to balance the pattern.
2. Loosen the 3 allen head screws on the end of the housing.
3. Loosen the jam nut on the jack screw and rotate the jack screw to move the motor assembly up or down as needed.
4. Tighten the 3 allen head screws.
5. Tighten the jam nut on the jack screw.
6. Re-test and readjust as necessary.

LEVELING THE SCRUB HEAD

Leveling the cylindrical head is accomplished by adjusting the lower links that attach the deck to the frame. To increase pattern width on rear brush, loosen lock nuts and shorten the lower links by screwing the rod into the threaded ends. To increase pattern width on front brush, lengthen the lower links by screwing the rod out of the threaded ends. After adjustment, be sure to tighten lock nuts.

MAINTENANCE-SCRUB DECK - CYLINDRICAL

⚠ WARNING: *Do not use a pressure washer to clean around the brush motors. Use tap pressure only.*

TO REPLACE SCRUB BRUSH MOTORS

1. With the scrub deck in the raised position, disconnect brush motor wiring connector from harness.
2. Remove side squeegee assembly.
3. Remove brushes and brush door.
4. Remove aluminum end housing from deck.
5. Separate brush motor with gear box from end housing.
6. Reverse to reassemble.
7. Adjust brush levelness as described in earlier section.

BRUSH MOTOR CARBON BRUSH REPLACEMENT

1. Scribe alignment mark on motor barrel to motor cap. Remove two bolts.
2. Remove end cap from motor.
NOTE: *Motors contain two wave washers in cap. Do not lose these.*
3. Release brush from spring tension. Remove screw connecting brush wire lead to brush holder. Clean brush holder to insure free movement.
4. Retract spring and install new brush. Install connector screw and lead.
5. When all new brushes are installed. Place all in retracted position, held into brush holder by spring tension.
6. Carefully place end cap onto bearing on motor shaft.
NOTE: Use care to assure wave washer alignment.
7. With end cap in partially installed position, release all brushes to contact position with motor commutator.

NOTE: Failure to insure all brushes are released will result in motor failure.

8. Reset end cap and realign with scribe marks on motor barrel. Reinstall the two attach bolts from cap into base.
9. Maintain alignment between motor barrel base and cap.

MAINTENANCE-SCRUB DECK - CYLINDRICAL

ACTUATOR SCRUB DECK REMOVAL/REPLACEMENT

FOR SAFETY: Before leaving or servicing machine, stop on a level surface. Turn off machine.

1. Lower scrub deck.
2. Disconnect spring assembly from actuator slide link.
3. Remove the clevis pin retaining the top of the actuator.
4. Remove slide link and actuator as an assembly by removing the two bolts connecting them to the deck through the bushings.
5. Either unthread the actuator main lead screw from the barrel, or remove the two bolts connecting the barrel to the slide link.
6. Reverse for re-installation.

SCRUB DECK ACTUATOR ADJUSTMENT

The actuator will need to be adjusted when replaced.

To adjust the actuator:

1. While holding actuator barrel to prevent it from spinning, apply power to the actuator such that it is fully extended. Positive power to white wire, and negative/ground to black. Limit switch within actuator will stop it.
2. Turn barrel out one or more full turns to assure that when it is retracted it will not bind against itself.
3. While holding actuator barrel to prevent it from spinning, apply power to the actuator such that it is fully retracted. Positive power to black wire, and negative/ground to white wire. Limit switch within actuator will stop it.
4. With actuator fully retracted, turn barrel in until it touches the base of the threaded shaft.
5. At the bottomed out position, turn the barrel out only enough to allow connection to slide link.
6. Connect actuator.
7. Check travel of actuator during operation.

MAINTENANCE-CIRCUIT PROTECTION

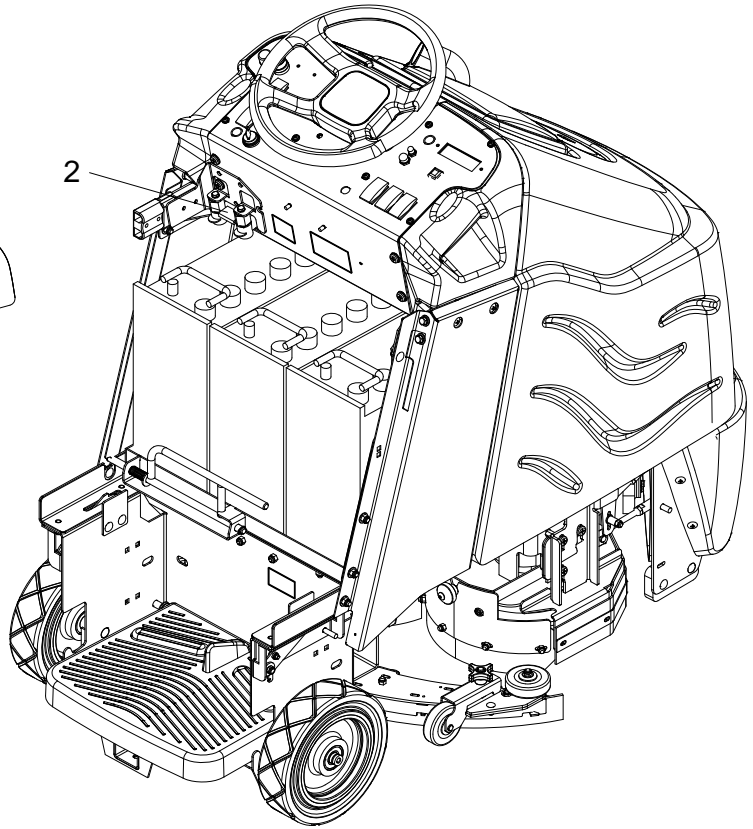
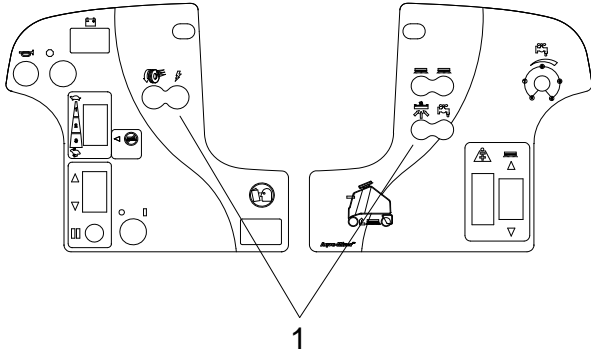

1. CIRCUIT BREAKERS (BASIC PANEL SHOWN)

Circuit breakers interrupt the flow of power in the event of an electrical overload. When a circuit breaker is tripped, reset it by pressing the exposed button. If a circuit breaker continues to trip, the cause of the electrical overload should be found and corrected.

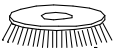

18 Amp. Protects the left scrub brush motor.

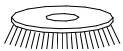

18 Amp. Protects the right scrub brush motor.



30 Amp. Protects the vacuum motor (Basic only).



30 Amp. Cylindrical
25 Amp. Disk
Protects the propel motor.



3 Amp. Protects the machine controls (Basic only).



3 Amp. Protects the pump (Basic only).

2. FUSE (DELUXE ONLY)

The fuse is a one-time circuit protection device designed to stop the flow of electrical current in the event of an electrical overload. If fuse is blown, it must be replaced.

The fuse is located inside the battery compartment.

MAINTENANCE-SOLUTION STRAINER & PUMP - DISK MODELS

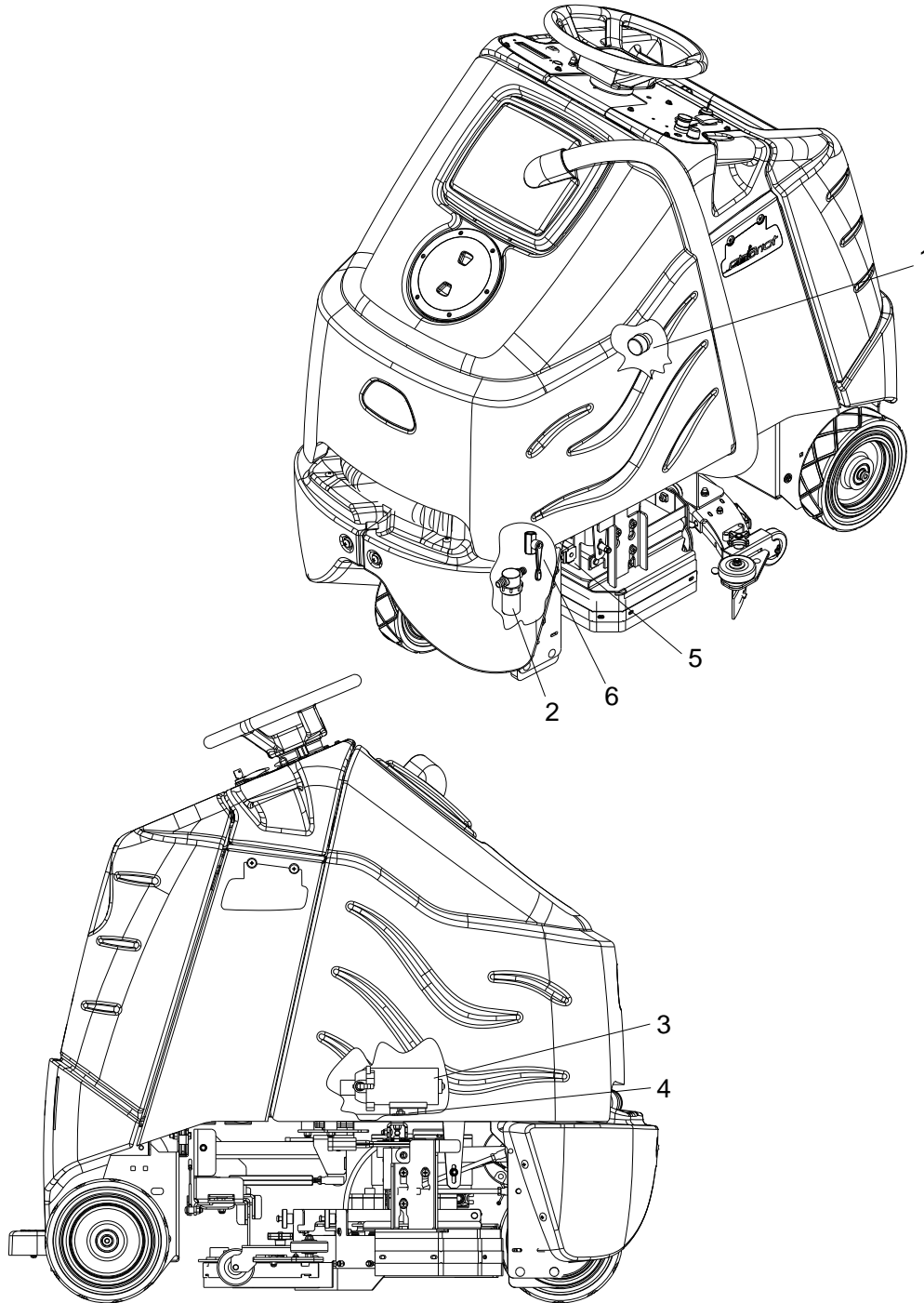

1. *Solution Strainer-Coarse*
2. *Solution Strainer-Fine*
3. *Pump*

4. *Pump Mounting Plate*
5. *Solenoid Valve*
6. *Shut-off Valve*

MAINTENANCE-SOLUTION STRAINER & PUMP-CYLINDRICAL MODELS

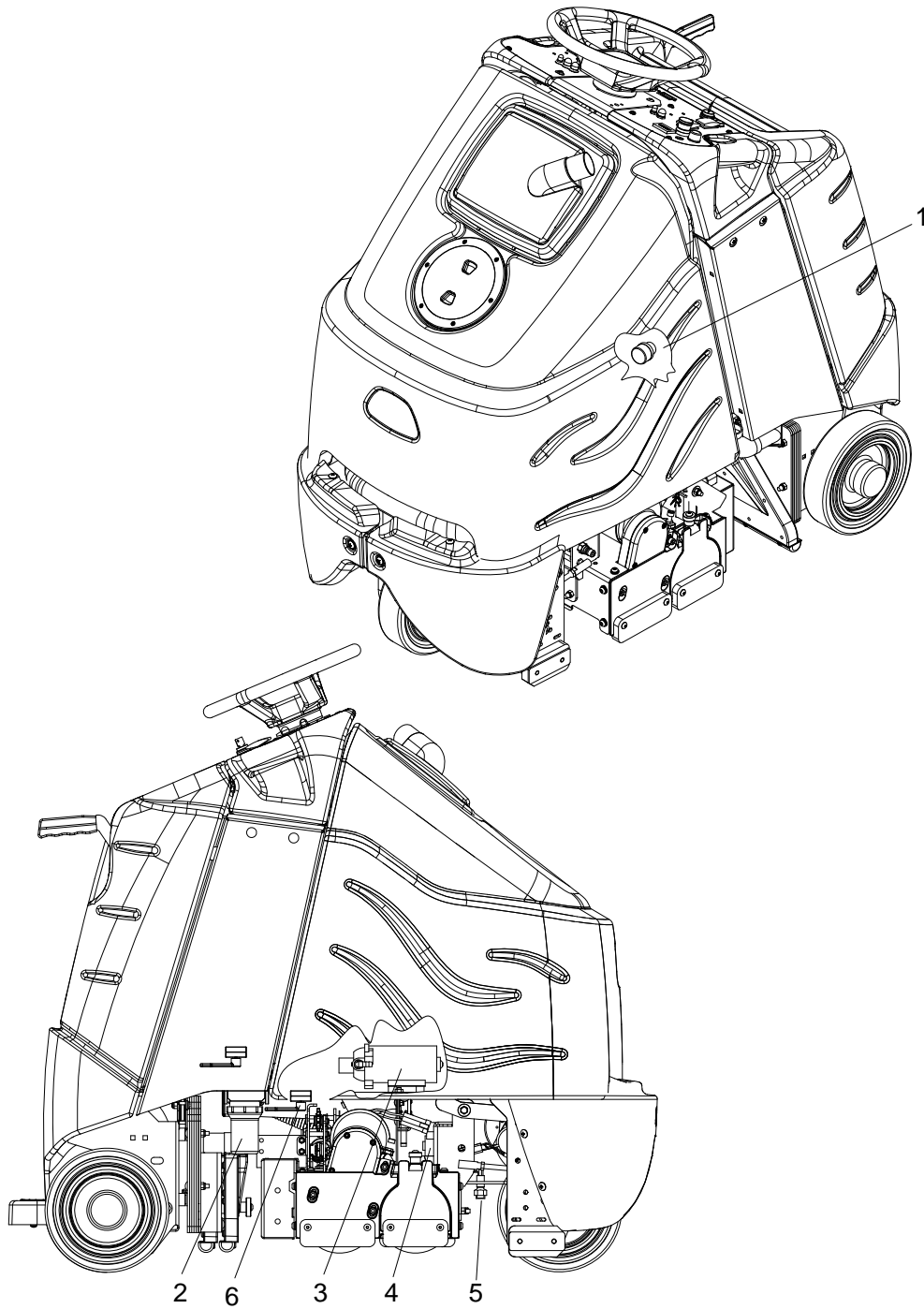

- 1. *Solution Strainer-Coarse*
- 2. *Solution Strainer-Fine*
- 3. *Pump*

- 4. *Solenoid Valve*
- 5. *Jets*
- 6. *Shut-off Valve*

MAINTENANCE-SOLUTION STRAINER & PUMP

1. SOLUTION STRAINER-COARSE

Located in bottom of tank. The coarse strainer protects the finer strainer from large debris. If the fine strainer is clean and the pump and solenoid valve are not working, then check the coarse strainer for debris. Drain the solution tank and clean the coarse strainer. To remove the strainer, rotate the strainer counterclockwise. Cleanout the debris from wire mesh and re-assemble.

2. SOLUTION STRAINER (FINE) AND SHUT-OFF VALVE

The fine strainer is located in front left corner of machine on disk models and in right rear corner of cylindrical models. The fine strainer protects the pump and solenoid valve from debris. If there is little or no solution flow to the ground, first check to make sure the shut-off valve is open. Next, check the strainer for debris. To remove the strainer, first turn the shut-off valve to the off position. Then, turn the bottom part of the strainer counterclockwise until the bottom is separated. Clean out the debris from the wire mesh and re-assemble. Make sure the O-ring gasket is in place when re-assembled. To resume flow, turn the shut-off valve to the open position.

3. PUMP

The pump is located under the tank on the right side of machine. The pump delivers solution from the tank to the scrub deck.

To repair or replace pump:

1. Remove scrub deck skirts, Aqua-Mizer, and squeegee from machine.
2. Lower scrub deck to gain access to pump mounting plate.
3. Remove screw that secures pump mounting plate to frame.
4. The pump is located under the tank on the right side of machine. The pump delivers solution from the tank to the scrub deck. Pull pump mounting plate forward and down to expose pump.
5. Reverse steps to install.

4. PUMP MOUNTING PLATE

See graphic representation on previous page.

5. SOLENOID VALVE

The solenoid valve is mounted on the front of the scrub deck, on left side.

The solenoid valve shuts off solution flow to scrub deck whenever scrubbing stops. To repair or replace solenoid valve, cut cable ties that secure it to deck.

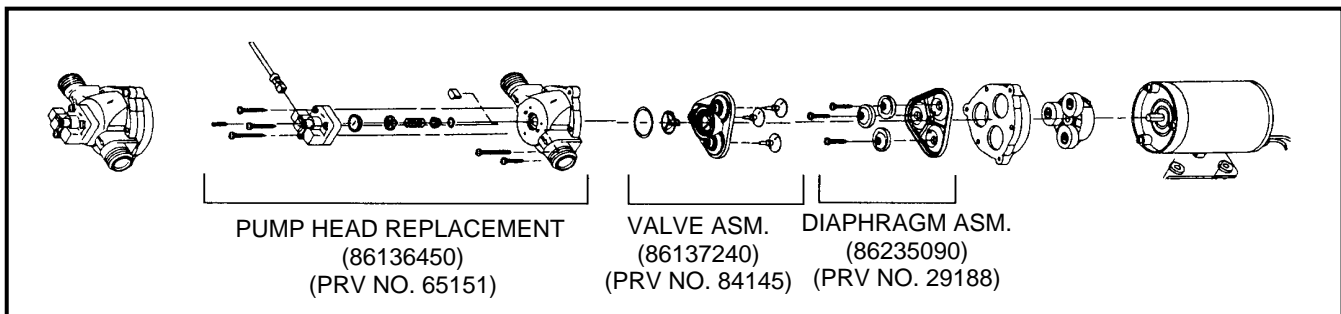

MAINTENANCE-VACUUM & FLOAT SHUT-OFF

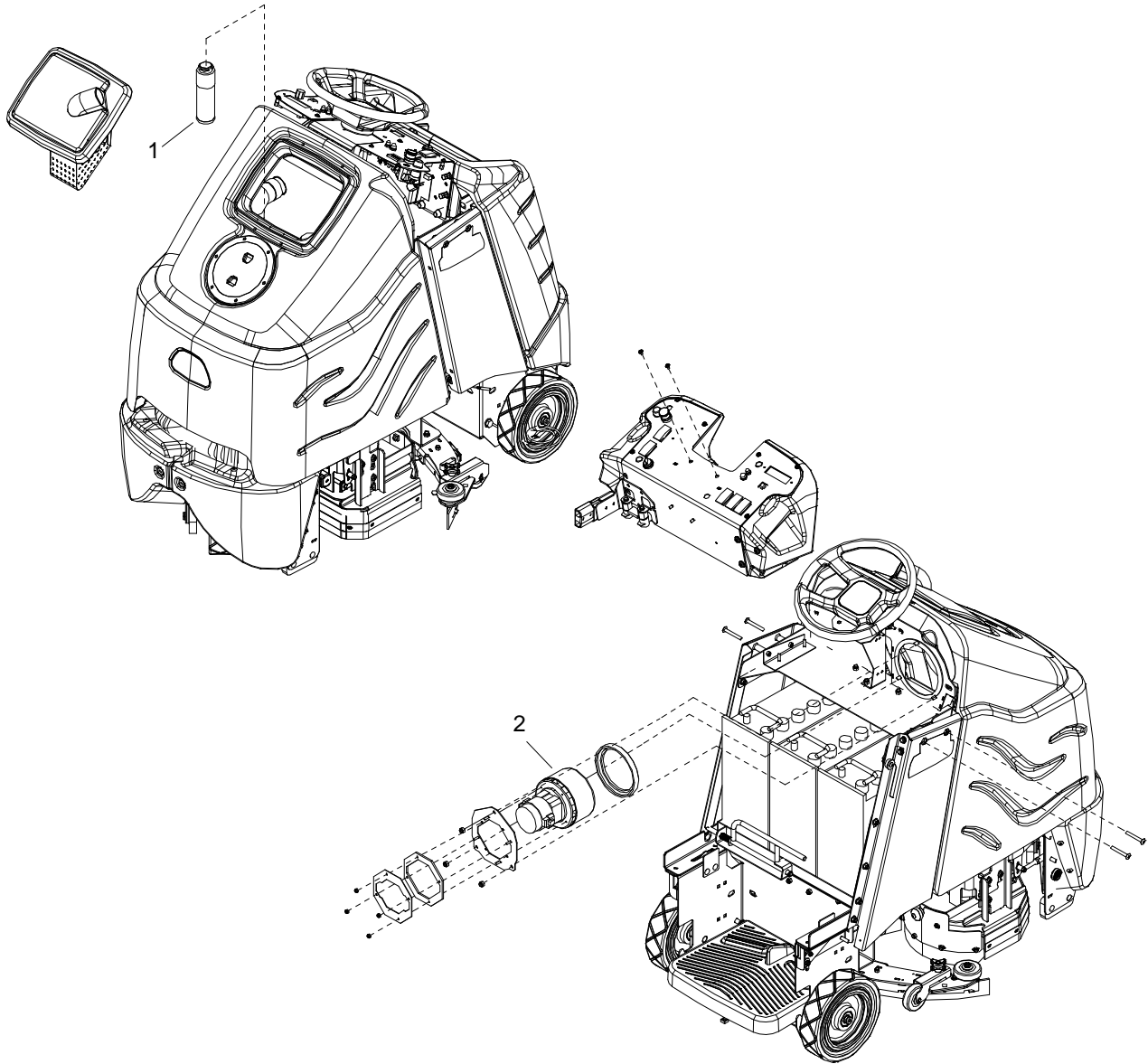

-
1. *Recovery tank float shut-off*
 2. *Vacuum motor*

MAINTENANCE-VACUUM & FLOAT SHUT-OFF

RECOVERY TANK FLOAT SHUT-OFF

When water is no longer being vacuumed from the floor and the vacuum fan is operating, the ball float has engaged. The vacuum motor will not vacuum water with recovery tank full. The recovery tank must be drained.

1. The float shut-off screen can be cleaned in or out of the machine.
2. To clean the float shut-off while it is inside the machine wipe material off screen then rinse. Check that the ball is also clean and moves freely.
3. To remove the float shut-off, grasp the screen with one hand and the connected tube with the other. Tilt and pull the float screen assembly to pull it off the barb on the tube.
4. To install, place one hand on the tube, and then tilt and push the float screen assembly over the barb on the tube.

FOR SAFETY: before leaving or servicing machine, stop on a level surface, turn off machine and disconnect power.

TO REPAIR OR REPLACE VACUUM MOTOR

1. Remove rear cover from machine.
2. Remove two screws from top of control panel and four screws from sides of control housing.
3. Slide control housing back from tank to expose vacuum motor.
4. Disconnect electrical connector from the vacuum motor.
5. Remove three nuts that secure vacuum motor retaining plate, remove plate and vacuum motor.
6. Reverse steps to install. Make sure that gasket is on vacuum so that vacuum seals against tank

Vacuum Motor Carbon Brushes

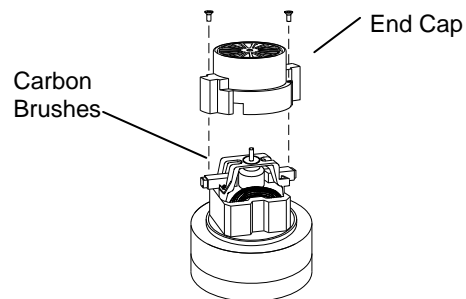

If armature commutator is grooved, extremely pitted or not concentric, the motor will need to be replaced or sent to a qualified service center.

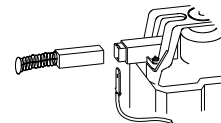

Important:

These brushes wear quicker as the length shortens due to increased heat. Spring inside brush housing will damage motor if brushes are allowed to wear away completely.

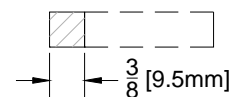

Periodically check the length of the carbon brushes. Replace both carbon brushes when either is less than 3/8" (9.5mm) long.

MAINTENANCE-DRIVE MOTOR & BRAKE

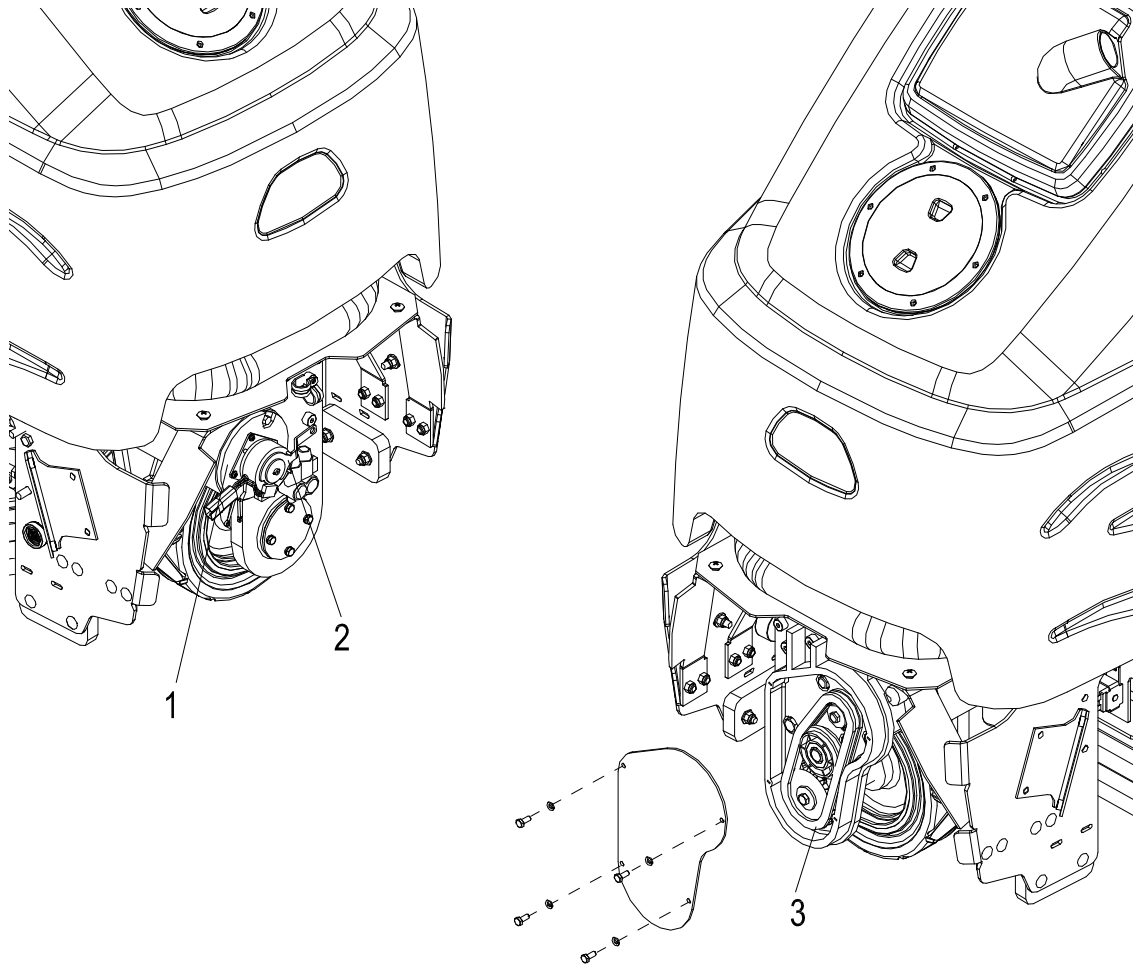

-
1. *Drive motor*
 2. *Parking brake*
 3. *Drive chain*

MAINTENANCE-DRIVE MOTOR & BRAKE

ELECTRIC PARKING BRAKE ENGAGEMENT

FOR SAFETY: Before leaving or servicing machine, stop on a level surface, turn off machine and remove key.

Electric Brake Engagement

This machine is equipped with an electric parking brake.

The brake automatically engages and keeps the machine from moving whenever the operator steps off the platform or when emergency stop is engaged.

The brake has a mechanical over-ride that can be engaged so machine can be pushed or towed (slowly).

When the mechanical over-ride is engaged the machine cannot be driven.

To engage brake:

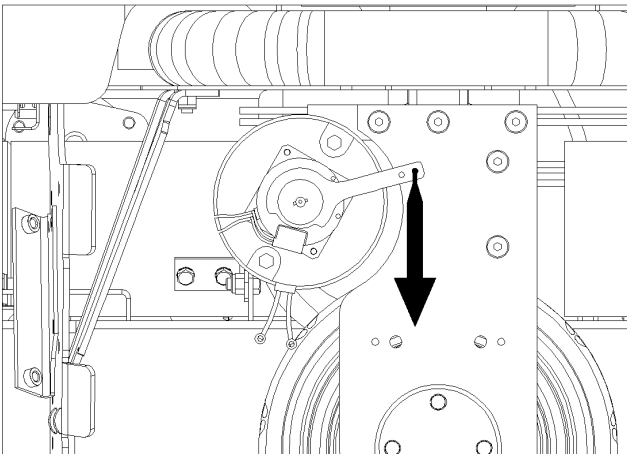

1. Mechanical over-ride engaged.
Machine can be pushed or towed (slowly).
2. Push lever firmly in direction of arrow

Note: There is an intermediate stop. Make sure lever is fully in the down position.

To disengage brake:

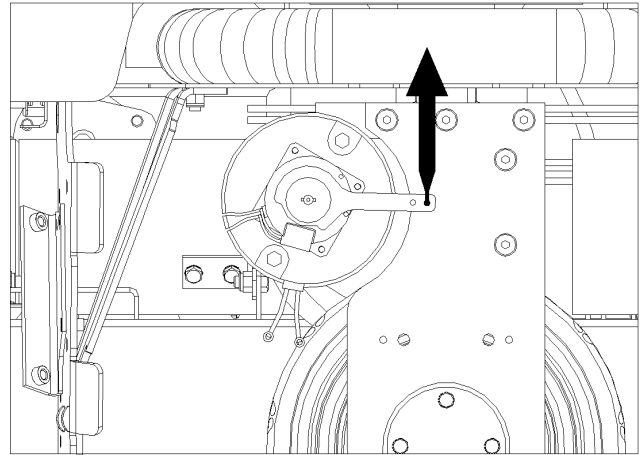

1. Mechanical over-ride disengaged
Machine can be driven.
2. Push lever firmly in direction of arrow.

MAINTENANCE-DRIVE MOTOR & BRAKE

DRIVE MOTOR CARBON BRUSH REPLACEMENT

⚠ WARNING: Do not use a pressure washer to clean around the motors. Use tap pressure only.

FOR SAFETY: Before leaving or servicing machine, stop on a level surface, turn off machine and remove key.

1. Disconnect batteries from machine.
2. Disconnect the electrical connection to the traction motor.

BRAKE REMOVAL

(Must be done to access carbon brushes)

3. Remove 4 mounting screws and remove brake.
4. Drive roll pin out of the hex hub enough to allow hex hub to slide off shaft. It is recommended that the roll pin be left partially in the hex hub.
5. Remove brush cap.

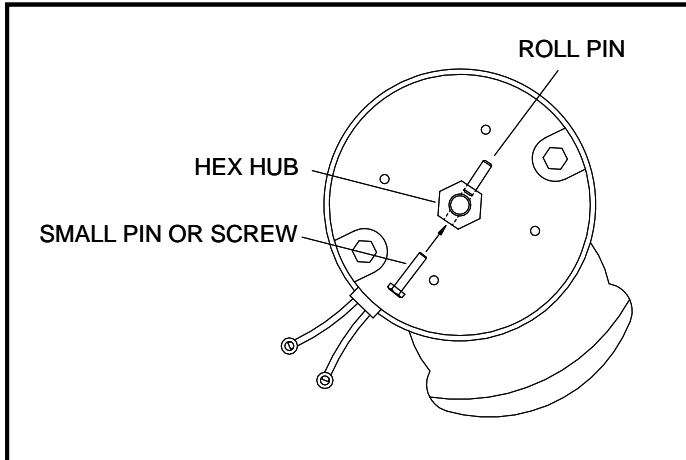

6. Release brush from spring tension. Remove screw connecting brush wire lead to brush holder. Clean brush holder to insure free movement.

5. Install new brush and reinstall connecting screw and lead.
6. When all new brushes are installed. Place all in retracted position, held into brush holder by spring tension.
7. Carefully replace brush cap.

Reinstalling:

10. When replacing the hex hub, use a small pin or screw to help align the holes.
11. Drive the pin into the hub and make sure it is flush to the hex surface. The brake will not fit on the hub if the roll pin is protruding from the hub.
12. Replace the hub and use Lock-Tite on the screws.

MAINTENANCE-BAG REPLACEMENT

REMOVING BAG

1. Disconnect batteries and make sure parking brake is not overridden.
2. Under left front side of machine loosen hose clamp on recovery dump hose. **Do not remove hose.**

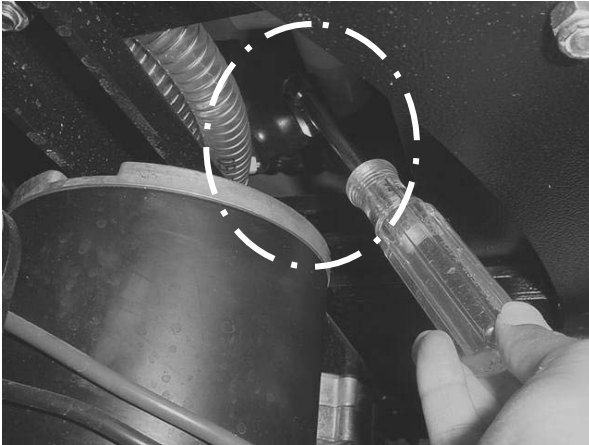

3. Remove Dome and set aside
4. Remove Float cage, loosen screw on elbow and remove elbow.
5. Remove the eight screws and nuts holding the bag clamps and set aside.
6. Remove clamps and set aside.
7. Pull mandrel from bottom of tank. Access can either be from the dirty water side or the clean water side or both. When replacing bag with new one be sure to save mandrel.



REPLACING BAG

1. Install mandrel in bottom of bag.
2. Place new bag in tank making sure hole for strainer basket is oriented properly.

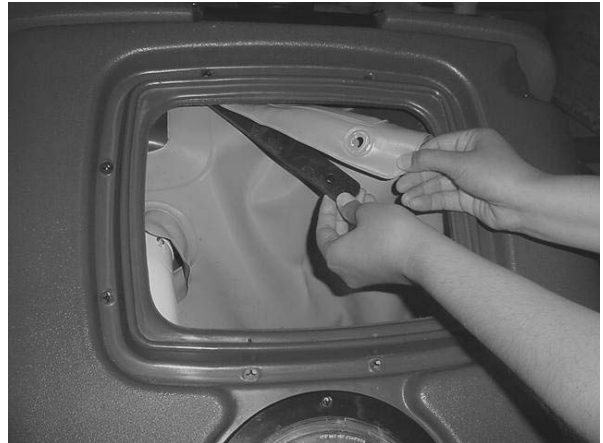

3. Angle mandrel and bag into tank fitting toward front of machine. Push mandrel into fitting until it bottoms out.
4. Attach bag to top of machine by rolling edge of bag over clamp strips.
5. Replace elbow and float cage.
6. Tighten clamp on bottom of machine.

MAINTENANCE-TRANSPORTING

PUSHING MACHINE

The machine may be pushed for short distances at speeds not to exceed 5 mph. Be careful to avoid damaging machine. The machine may be pushed by hand from the rear.

NOTE: To avoid damage caused by regenerative voltage, disconnect traction motor before towing or pushing machine.

MACHINE TIE-DOWNS

There are two tie points located at front and each side of foot box frame and two at the front side of frame. Tie-down devices must be of the proper type and strength. The combined strength of all tie-downs must be strong enough to lift two times the weight of the machine. Tie-downs must be positioned to prevent the machine from moving forward, backward, or either side to side. Use all four corners of the machine with the tie-downs running out opposite directions. Tie-downs must be attached to the transporting vehicle securely.

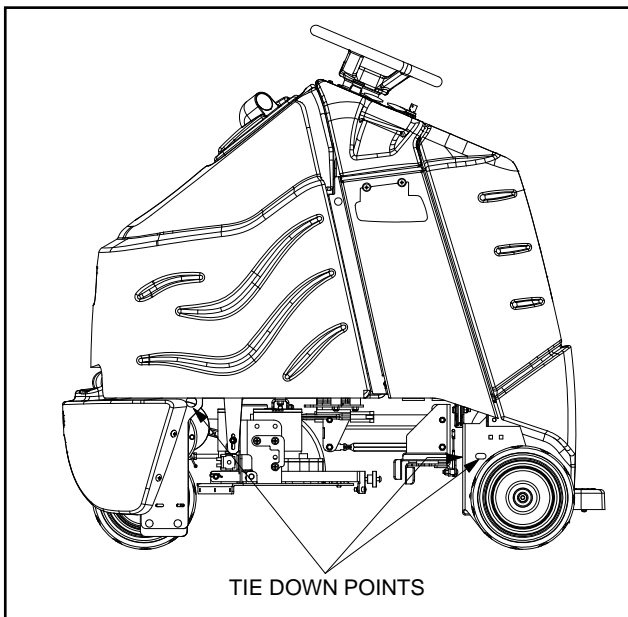



PREPARATION FOR LOADING /UNLOADING TRAILER



Before loading or unloading machine from trailer, remove squeegee, scrub deck, side skirts or side squeegees, Aqua-Mizers and scrub brushes (pads) to eliminate interference with tie-downs. Scrub head must be in the up position before loading.

NOTE: When transporting the machine on a trailer or in a truck, in addition to using tie-downs, be sure to set the parking brake, and block the tires to prevent the machine from rolling.

MACHINE TROUBLESHOOTING

PROBLEM	CAUSE	ERROR CODE DELUXE	SOLUTION
No power to machine	Battery disconnected		Check all battery cable connections
	Emergency shut-off activated		Reset
	Battery cables corroded		Clean connections
	Main fuse blown (Deluxe Only)		Replace fuse
	Faulty key switch		Replace switch
Little or no propel	Low battery charge		Charge batteries
	Machine turned on with pedal not in neutral position		Allow pedal to return to neutral. Restart
	Tripped circuit breaker		Reset circuit breaker
	Wheels spin		Decrease brush pressure
	Controller overheated	7802/7801	Allow cool down period
	Loose motor connection	7800	Check wires and connections from controller to motor
	Faulty throttle circuit or potentiometer	0814	Check wires and connections from throttle to LCD controller and potentiometer resistance
	Faulty drive reset circuit or switch		Check wires, connections and switch
	Faulty operator presence pedal circuit or switch		Check wires, connections and switch
	Faulty platform circuit or switch		Check wires, connections and switch
	Brake over-ride engaged		Disengage brake over-ride
	Faulty brake circuit or over-ride switch		Check wires, connections and switch
Machine does not change speeds	Faulty speed control circuit or switch		Check wires, connections and switch
Forward speed only Reverse speed only	Faulty forward/reverse switch		Replace switch
Poor or no water pickup	Squeegee out of adjustment		Adjust squeegee
	Debris caught on squeegee		Remove debris
	Worn squeegee blades		Rotate or replace squeegee blades
	Vacuum hose clogged		Clear obstruction from hose
	Vacuum hose disconnected from squeegee or recovery tank dome		Reconnect vacuum hose
	Recovery tank float system dirty		Clean float system
	Recovery tank not sealed		Place recovery tank dome on tank. Replace damaged gaskets
	Float-ball shut-off engaged Tank full		Empty recovery tank
	Foam filling recovery tank		Empty recovery tank. Use less or different detergent. Use defoamer.

MACHINE TROUBLESHOOTING

PROBLEM	CAUSE	ERROR CODE DELUXE	SOLUTION
Vacuum motor does not run, or runs slowly	Circuit breaker tripped (Basic)		Reset circuit breaker
	Faulty vacuum circuit or switch	7700	Check wires, connections and switch
	Worn vacuum motor brushes		Replace brushes, check commutator
Squeegee will not go up/down	Faulty circuit or actuator (Deluxe)		Check wires, connectors and actuator
	Faulty cables or pulleys		Repair/replace cables or pulleys
Poor scrubbing performance	Debris caught in scrub brushes		Remove debris
	Worn brushes or pads		Replace brushes or pads
	Improper detergent, brush or pad used		Contact equipment or application specialists
	Low scrub brush down pressure		Increase brush pressure
	Low battery charge		Charge batteries
Little or no solution flow to the floor	Solution tank empty		Fill solution tank
	Solution flow turned off or set too low		Turn on or increase flow setting
	Solution strainer plugged		Clean solution strainer
	Solution system plumbing obstructed		Clear obstruction from plumbing
	Pump obstructed		Clean or replace pump
	Solution solenoid valve obstructed or stuck		Clean or replace valve
	Solution shut-off valve is closed		Open shut-off valve
	Faulty pump circuit or pump		Check wiring, connections, control board (Basic) and pump.
	Faulty solenoid		Check solenoid valve
Brush motors do not run, or run slowly	Circuit breaker(s) tripped	7600	Reset circuit breaker(s)
	Low battery charge		Charge battery
	Fault brush circuit or motor	7600	Check wires, connections and motor
	Worn brush motor brushes		Replace brushes, check commutator
Scrub deck will not go down/up	Actuator circuit breaker tripped (Basic)		Reset breaker
	Faulty actuator circuit or actuator		Check wires, connections and actuator
Scrub deck goes down, then raises	No brushes or pad drivers on machine	9000	Install brushes or pad drivers
Error code not listed is displayed	Controller detects electrical problem		Contact service technician

MACHINE TROUBLESHOOTING – DELUXE CONTROLLER FAULT CODES

ERROR CODE DELUXE	PROBLEM	SOLUTION
None	LCD display on, but incomplete	Disconnect batteries and wait 1 minute before re-applying power.
0A01	Power down error	Disconnect batteries and wait 1 minute before re-applying power.
0204	Memory corrupt	Replace controller.
All 080_ codes	Throttle wiring	Check for short or open circuits in throttle wiring.
All 140_ Codes		Check for short circuit between B+ and traction output.
All 310_ Codes	Possible short circuit of motors, auxiliary outputs (headlight, recycle pump, or back-up alarm), wiring or damaged controller	Check for short circuits. If code is present after short circuits are repaired, replace controller.
7500	LCD module communications timeout	Wiring fault on 6-way serial link between controller and display.
7501	LCD module settings corrupt	Disconnect batteries and wait 1 minute before re-applying power.
All 760_ Codes	Brush motor or brush circuit fault	Check for short or open circuits in brush motors or wiring.
All 770_ Codes	Vacuum motor or vacuum circuit fault	Check for short or open circuits in vacuum motor(s) or wiring.
7800	Traction motor open circuit fault	Check for open circuit on propel motor or wiring.
7801	Traction motor overcurrent error	Check for short circuit on propel motor or wiring.
7802	Traction motor in power foldback state	Propel motor current has exceeded current limit for the foldback time.
All 790_ Codes	Emergency stop error	E-stop input active or wiring fault.
9000	Brush current requirement not satisfied	Check that brushes or pads are installed. Check for open circuit in scrub lift actuator, circuit breaker or wiring.

MACHINE TROUBLESHOOTING- CONTROLLER FAULT CODES

PROPEL CIRCUIT BOARD TROUBLESHOOTING

Curtis 1228 LED DIAGNOSTICS- Basic and Cylindrical

During normal operation, with no faults present, the status LED is steadily on. If the controller detects a fault, the status LED provides two types of information. First, it displays a slow flash (2 Hz) or a fast flash (4 Hz) to indicate the severity of the fault. Slow-flash faults are self-clearing; as soon as the fault is corrected, the vehicle will operate normally. Fast-flash faults (“.” in Table 2) are considered to be more serious in nature and require that the key switch be cycled to resume operation after the fault is corrected.

After the severity indication has been active for 10 seconds, the status LED flashes a 2-digit fault identification code continuously until the fault is corrected. For example, code “1,4”—low battery voltage—appears as: one LED flash, followed by a pause, then 4 LED flashes, and then repeats.

LED CODE	PROGRAMMER LCD DISPLAY	EXPLANATION	POSSIBLE CAUSE
1,1	THERMAL CUTBACK	over-/under-temperature cutback	<ol style="list-style-type: none"> 1. Temperature >92°C or < -25°C. 2. Excessive load on vehicle. 3. Operation in extreme environments. 4. Electromagnetic brake not releasing.
1,2	THROTTLE FAULT 1	throttle fault	<ol style="list-style-type: none"> 1. Throttle input wire open or shorted. 2. Throttle pot defective. 3. Wrong throttle type selected.
1,3	SPD LIMIT POT FAULT	speed limit pot fault	<ol style="list-style-type: none"> 1. Speed limit pot wire(s) broken or shorted. 2. Broken speed limit pot.
1,4	LOW BATTERY VOLTAGE	battery voltage too low	<ol style="list-style-type: none"> 1. Battery voltage <17 volts. 2. Bad connection at battery or controller.
1,5	OVERVOLTAGE	battery voltage too high	<ol style="list-style-type: none"> 1. Battery voltage >36 volts. 2. Vehicle operating with charger attached. 3. Intermittent battery connection.
2,1	MAIN OFF FAULT	main contactor driver Off fault	<ol style="list-style-type: none"> 1. Main contactor driver failed open.
2,3	MAIN CONT FLTS	main contactor fault	<ol style="list-style-type: none"> 1. Main contactor welded or stuck open. 2. Main contactor driver fault. 3. Brake coil resistance too high.
2,4	MAIN ON FAULT	main contactor driver On fault	<ol style="list-style-type: none"> 1. Main contactor driver failed closed.

MACHINE TROUBLESHOOTING- CONTROLLER FAULT CODES

LED CODE	PROGRAMMER LCD DISPLAY	EXPLANATION	POSSIBLE CAUSE
3,1	PROC/WIRING FAULT	HPD fault present for >10 sec.	1. Misadjusted throttle. 2. Broken throttle pot or throttle mechanism.
3,2	BRAKE ON FAULT	brake On fault	1. Electromagnetic brake driver shorted. 2. Electromagnetic brake coil open.
3,3	PRECHARGE FAULT	precharge fault	1. Low battery voltage. 2. KSI and throttle turned on at same time.
3,4	BRAKE OFF FAULT	brake Off fault	1. Electromagnetic brake driver open. 2. Electromagnetic brake coil shorted.
3,5	HPD	HPD (High Pedal Disable) fault	1. Improper sequence of throttle and KSI, push, or inhibit inputs. 2. Misadjusted throttle pot.
4,1	CURRENT SENSE FAULT	current sense fault	1. Short in motor or in motor wiring. 2. Controller failure. *
4,2	HW FAILSAFE	motor voltage fault (hardware)	1. Motor voltage does not correspond to throttle request. 2. Short in motor or in motor wiring. 3. Controller failure. *
4,3	EEPROM FAULT	EEPROM fault	1. EEPROM failure or fault.
4,4	POWER SECTION FAULT	power section fault	1. EEPROM failure or fault. 2. Short in motor or in motor wiring. 3. Controller failure.



chariot
PARTS

BUMPER

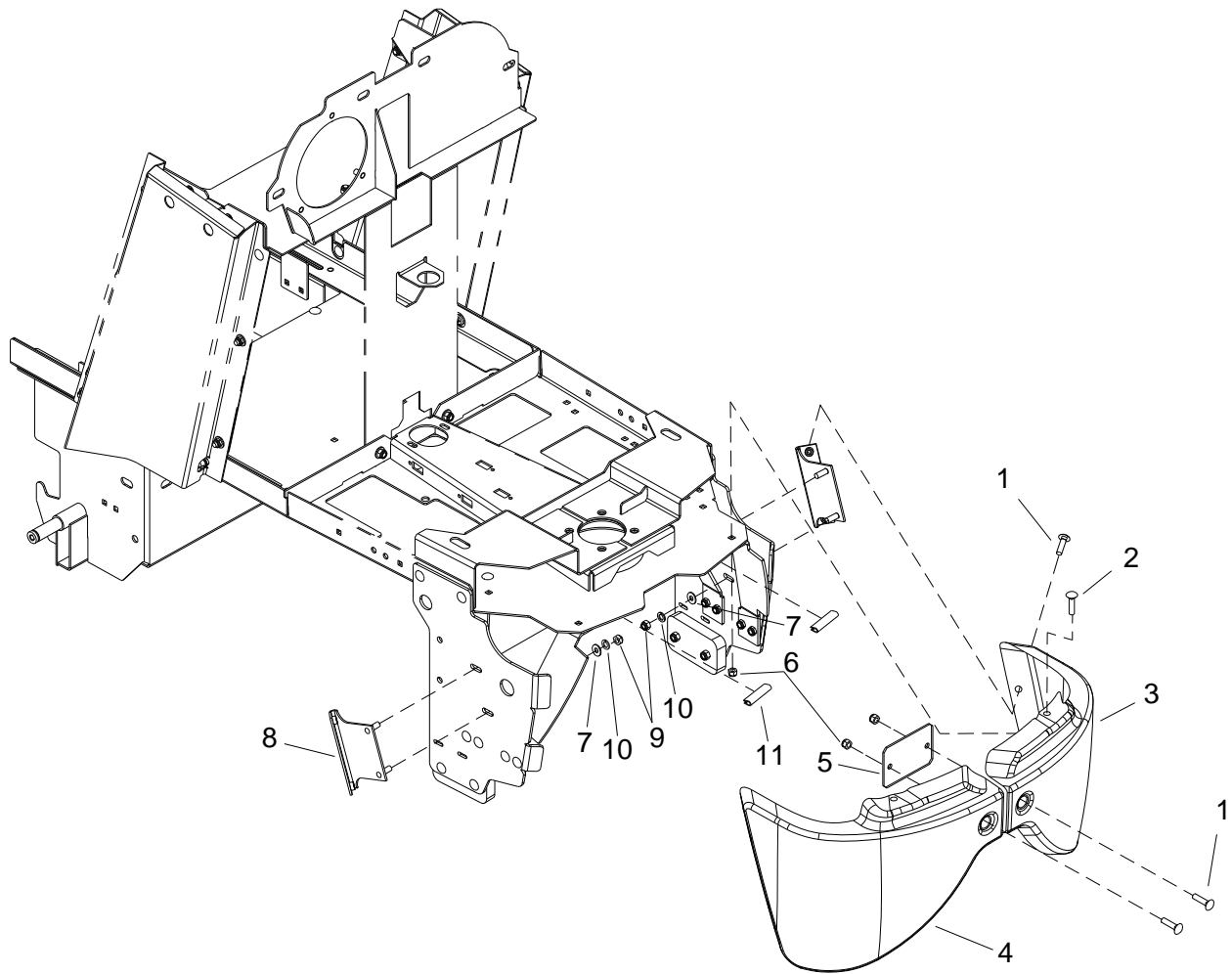

BUMPER

REF	PART NO.	PRV NO.	QTY	DESCRIPTION	SERIAL NO. FROM	NOTES:
1	86276890	70752	6	SCR, 5/16-18X3/4 PTHMS SS		
2	86007070	70849	2	SCR, 5/16-18X1.00 PPHMS SS		
3	86063230	140813	1	BUMPER, LEFT		
4	86063240	140814	1	BUMPER, RIGHT		
5	86071020	140783	1	BRKT, FRONT BUMPER		
6	86270830	57023	4	NUT, 5/16-18 HEX NYLOCK SS		
7	86010670	87029	4	WASHER, 5/16 FLAT SS		
8	86070730	140729	2	BRKT, BUMPER MOUNT, SIDE		
9	86197040	57264	4	NUT, 5/16-18 HEX ACORN PLTD		
10	86279130	87083	4	WASHER, 5/16 SPLIT LOCK PLTD		
11	86251750	67602	2	RISER, BUMPER		

CONTROL PANEL-BASIC-CYLINDRICAL

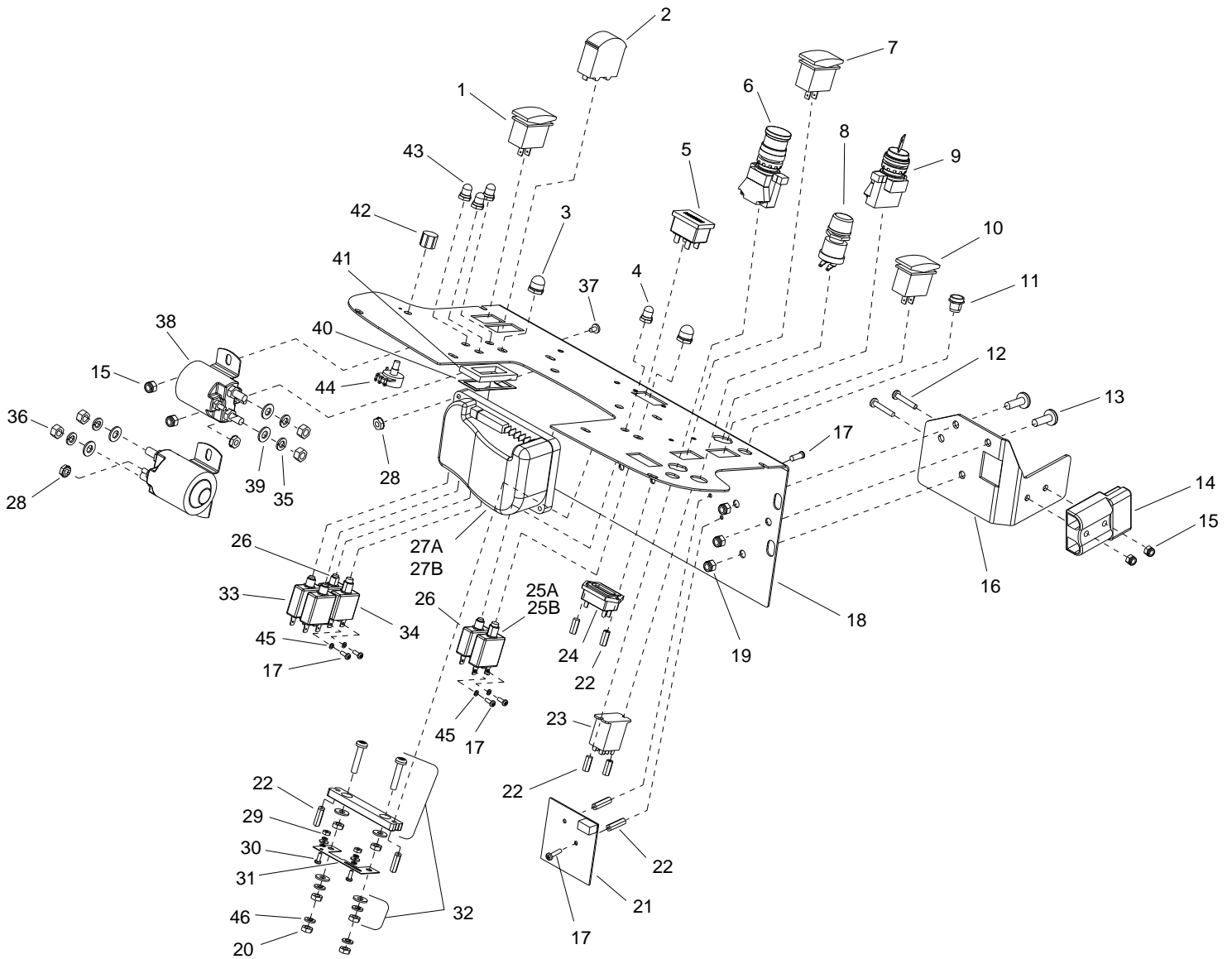

CONTROL PANEL-BASIC-CYLINDRICAL

REF	PART NO.	PRV NO.	QTY	DESCRIPTION	SERIAL NO. FROM	NOTES:
1	86007210	72165	1	SWITCH, DPDT 3-POSITION ROCKER		
2	86246980	54201	1	METER, 0-50 AMP DC		
3	86008900	80845	2	BOOT, SEAL-PUSH BUTTON 7/16-28		
4	86002010	14942	1	BOOT, 3/8 CIRCUIT BREAKER		
5	86005560	54199	1	METER, 36V LED BATTERY		
6	86007180	72160	1	SWITCH, EMERGENCY STOP		
7	86257110	72189	1	SWITCH, 4P3T FIXED POS ROCKER		
8	86257280	81371	1	SWITCH, PUSH BUTTON		
9	86007190	72161	1	SWITCH KEY DPSTN		
10	86007140	72130	1	SWITCH, SPST 2-POSITION ROCKER		
11	86257140	72196	1	SWITCH, RESET PB ROUND		
12	86273820	70019	2	SCR, 1/4-20 X 1.25 HHCS		
13	86277480	70850	3	SCR, 5/16-18 X 1/2 PTHMS SS		
14	86008760	80682	1	CONN, 175 DCA GRY W/O TERMS		
15	86005810	57245	6	NUT, 1/4-20 HEX NYLOCK SS		
16	86070720	140728	1	BRKT, BATT CONN, BASIC		
17	86273990	70067	8	SCR, 6-32 X 3/8 PPHMS		
18	86078150	61475	1	PANEL, BASIC		
19	86271840	57285	3	NUT, 5/16-18 HEX NYLOCK THIN SS		
20	86005710	57105	2	NUT, 1/4-20 HEX W/STAR WASHER		
21	86003250	27944	1	CIRCUIT BOARD, SOL FLOAT WIRED		
22	86255900	73538	8	STANDOFF, 6-32 X 5/8 HEX NYL		
23	86251410	67506	1	RELAY, 15A 36V MINI		
24	86005530	54154	1	METER, 12-48 VDC LED HOUR		
25A	86001910	14606	1	BREAKER, 30A 50VDC CIRCUIT	*(1)	WAS 14607, 25A
25B	86001920	14607	1	BREAKER, 25A 50VDC CIRCUIT	*(16)	CYLINDRICAL ONLY
26	86002000	14717	2	BREAKER, 3 AMP		
27A	86002760	270092	1	CONTROLLER, CHAIN DRIVE BASIC		FOR 29269-DRIVE UNIT (CHAIN)
27B	86027740	27911	1	CONTROLLER, GEAR DRIVE BASIC		FOR 29276- DRIVE UNIT (GEAR)
28	86005700	57104	10	NUT, 10-32 W/STAR WASHER PLTD		
29	86271790	57256	2	NUT, 6-32 HEX BRASS		
30	86276250	70615	2	SCR, 6-32 X 3/8 SRHMS BR		
31	86008190	73988	1	SHUNT, DC AMM. 15 AMP, 50 MV		
32	86229770	140805	1	BLOCK, SHUNT MOUNT		
33	86001730	140804	2	BREAKER, 18A 250VAC, 50VDC		
34	86001910	14606	1	BREAKER, 30A 50VDC CIRCUIT		
35	86279130	87083	4	WASHER, 5/16 SPLIT LOCK PLTD		
36	86271120	57125	4	NUT, 5/16-18 BRASS		
37	86223740	70872	4	SCR, 1/4-20 X .59 PPHMS SS C		
38	86006370	67315	2	RELAY, 36VDC 100AMP HVY DUTY		
39	86010670	87029	4	WASHER, 5/16 FLAT SS		
40	86249290	62283	1	PLATE, METER RETAINING		
41	86237830	35264	1	GASKET, AMP METER		
42	86242110	48088	1	KNOB, .90 OD X .25 COLLET		
43	86002010	14942	3	BOOT, 3/8 CIRCUIT BREAKER		
44	86006310	66335	1	POTENTIOMETER, 50K OHMS		
45	86279300	87134	4	WASHER, #6 LOCK		
46	86010630	87013	2	WASHER, 1/4 ID X 5/8 OD SS		

*SEE SERIAL NUMBER PAGE.

CONTROL PANEL-DELUXE

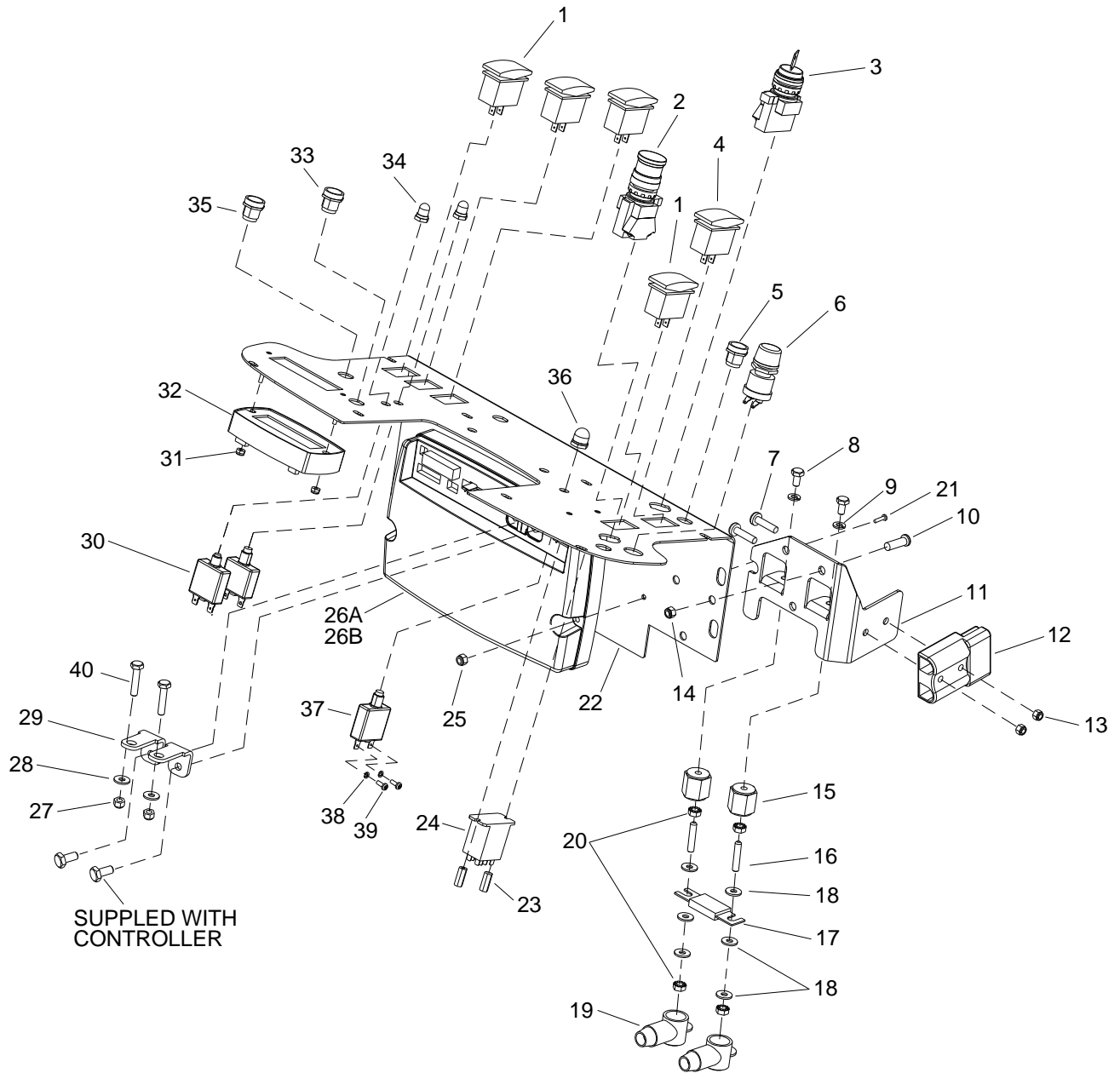

CONTROL PANEL-DELUXE

REF	PART NO.	PRV NO.	QTY	DESCRIPTION	SERIAL NO. FROM	NOTES:
1	86007520	730142	3	SWITCH, SPDT 3-POSITION MOM		
2	86007180	72160	2	SWITCH, EMERGENCY STOP		
3	86007190	72161	1	SWITCH KEY DPST		
4	86007140	72130	1	SWITCH, SPST 2-POSITION ROCKER		
5	86257140	72196	2	SWITCH, RESET PB ROUND		
6	86257280	81371	1	SWITCH, PUSH BUTTON		
7	86273820	70019	2	SCR, 1/4-20 X 1.25 HHCS		
8	86273830	70020	2	SCR, 1/4-20 X 1/2 HHCS SS		
9	86010780	87162	2	WASHER, 1/4 SPLIT LOCK PLTD		
10	86277480	70850	3	SCR, 5/16-18 X 1/2 PTHMS SS		
11	86070670	140722	1	BRKT, BATTERY CONNECTOR		
12	86008760	80682	1	CONN, 175 DCA GRY W/O TERMS		
13	86005810	57245	2	NUT, 1/4-20 HEX NYLOCK SS		
14	86271840	57285	3	NUT, 5/16-18 HEX NYLOCK THIN SS		
15	86255910	73659	2	STANDOFF, 1/4-20 X 1.0 HEX INS		
16	86006850	70393	2	SET SCR, 1/4-20 X 1.25L		
17	86008790	80687	1	FUSE, 125 AMP		
18	86010630	87013	6	WASHER, 1/4 ID X 5/8 OD SS		
19	86008920	80889	2	BOOT, RUBBER TERM. ISOLATOR		
20	86005710	57105	4	NUT, 1/4-20 HEX W/STAR WASHER		
21	86274410	70195	2	SCR, 10-32 X 1.25 PPHMS SS		
22	86078160	61476	1	PANEL, DELUXE		
23	86255900	73538	2	STANDOFF, 6-32 X 5/8 HEX NYL		
24	86251410	67506	1	RELAY, 15A 36V MINI		
25	86270990	57090	2	NUT, 10-32 HEX NYLOCK SS		
26A	86002770	270095	1	CONTROLLER, CHAIN DRIVE DELUXE		FOR 29269 DRIVE UNIT, CHAIN
26B	86292580	-	1	CONTROLLER, GEAR DRIVE DELUXE		FOR 29276 DRIVE UNIT, GEAR
27	86271910	57295	2	NUT, 5/16-18 FLEXLOCK		
28	86010670	87029	2	WASHER, 5/16 FLAT SS		
29	86068850	140219	2	BRKT, CABLE ATTACH		
30	86001730	140804	2	BREAKER, 18A 250VAC, 50VDC		
31	86270920	57049	2	NUT, 6-32 HEX NYLOCK SS		
32	86005570	54200	1	MODULE, LCD DELUXE		
33	86007480	730124	1	SWITCH ASM, SEALED PUSHBUTTON		
34	86002010	14942	2	BOOT, 3/8 CIRCUIT BREAKER		
35	86257130	72195	1	SWITCH, ON -TOUCH PB ROUND		
36	86001260	140218	1	BOOT, DB 3/8-27 UNS 2B	*(11)	WAS 80845
37	86001950	14666	1	BREAKER, 30A W/AUX CONTACT	*(11)	WAS 14606
38	86279300	87134	2	WASHER, #6 LOCK		
39	86273990	70067	2	SCR, 6-32 X 3/8 PPHMS		
40	86275760	70540	2	SCR, 5/16-18 X 1 HHCS GR8 PLTD		

*SEE SERIAL NUMBER PAGE.

CONTROL PANEL HOUSING

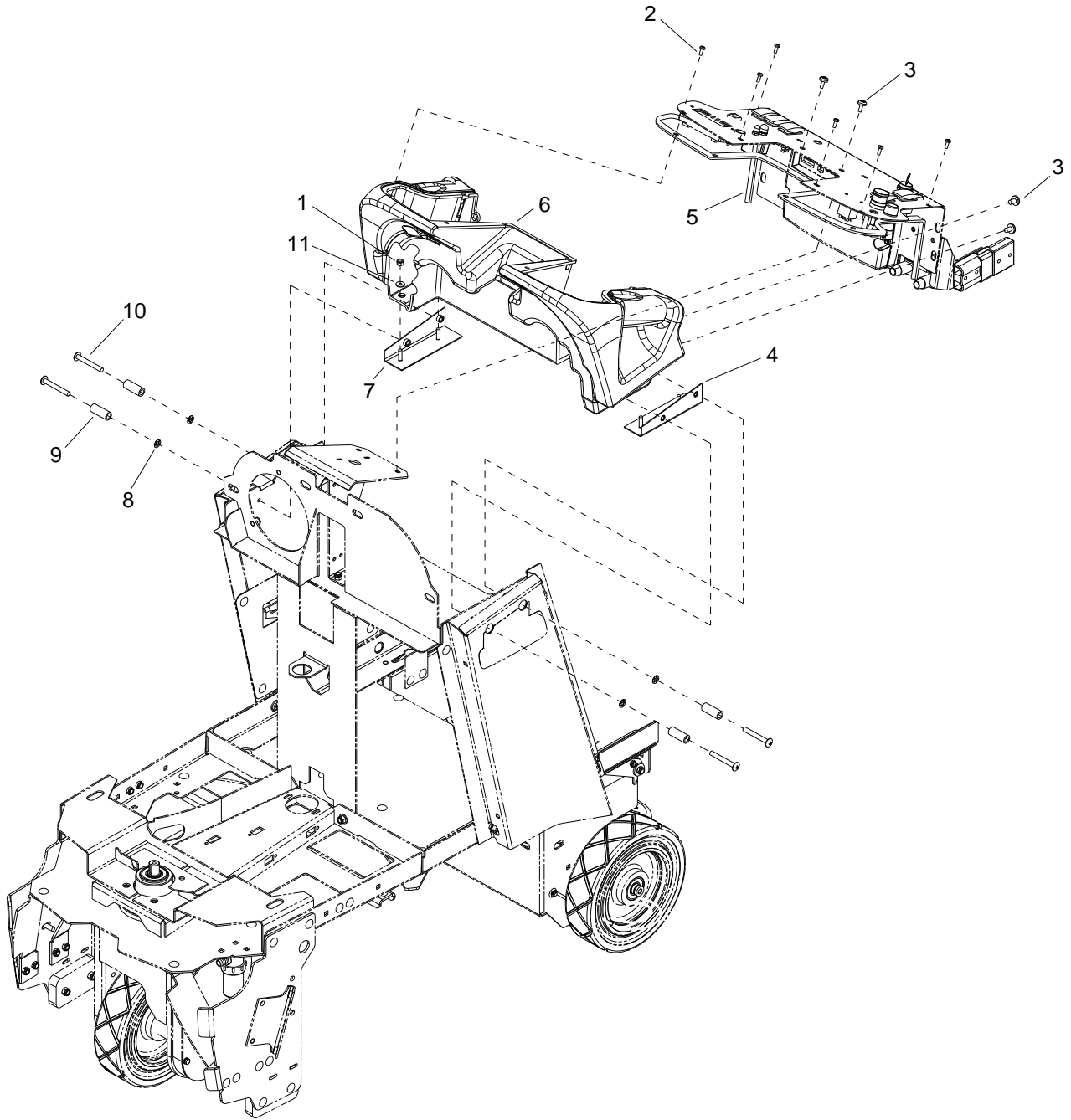

CONTROL PANEL HOUSING

REF	PART NO.	PRV NO.	QTY	DESCRIPTION	SERIAL NO. FROM	NOTES:
1	86005810	57245	4	NUT, 1/4-20 HEX NYLOCK SS		
2	86290540	-	6	SCR, 10-32 X 1/2 TORX SS BLK NP		
3	86277480	70850	6	SCR, 5/16-18 X1/2 PTHMS SS		
4	86070710	140726	1	BRKT, LEFT CONSOLE MOUNT		
5	86237900	35278	3	GASKET, .125 X .25W X 23L		
6	86031730	270084	1	CONSOLE		
7	86070700	140725	1	BRKT, RIHGT CONSOLE MOUNT		
8	86279750	87252	4	WASHER, RET, PUSHNUT, 5/16 BOLT		
9	86089650	78524	4	TUBE, 5/8 OD X .357 ID X 1.57		
10	86277420	70841	4	SCR, 5/16-18 X 2.5 PTHMS SS		
11	86010630	87013	4	WASHER, 1/4 ID X 5/8 OD SS		

DECAL

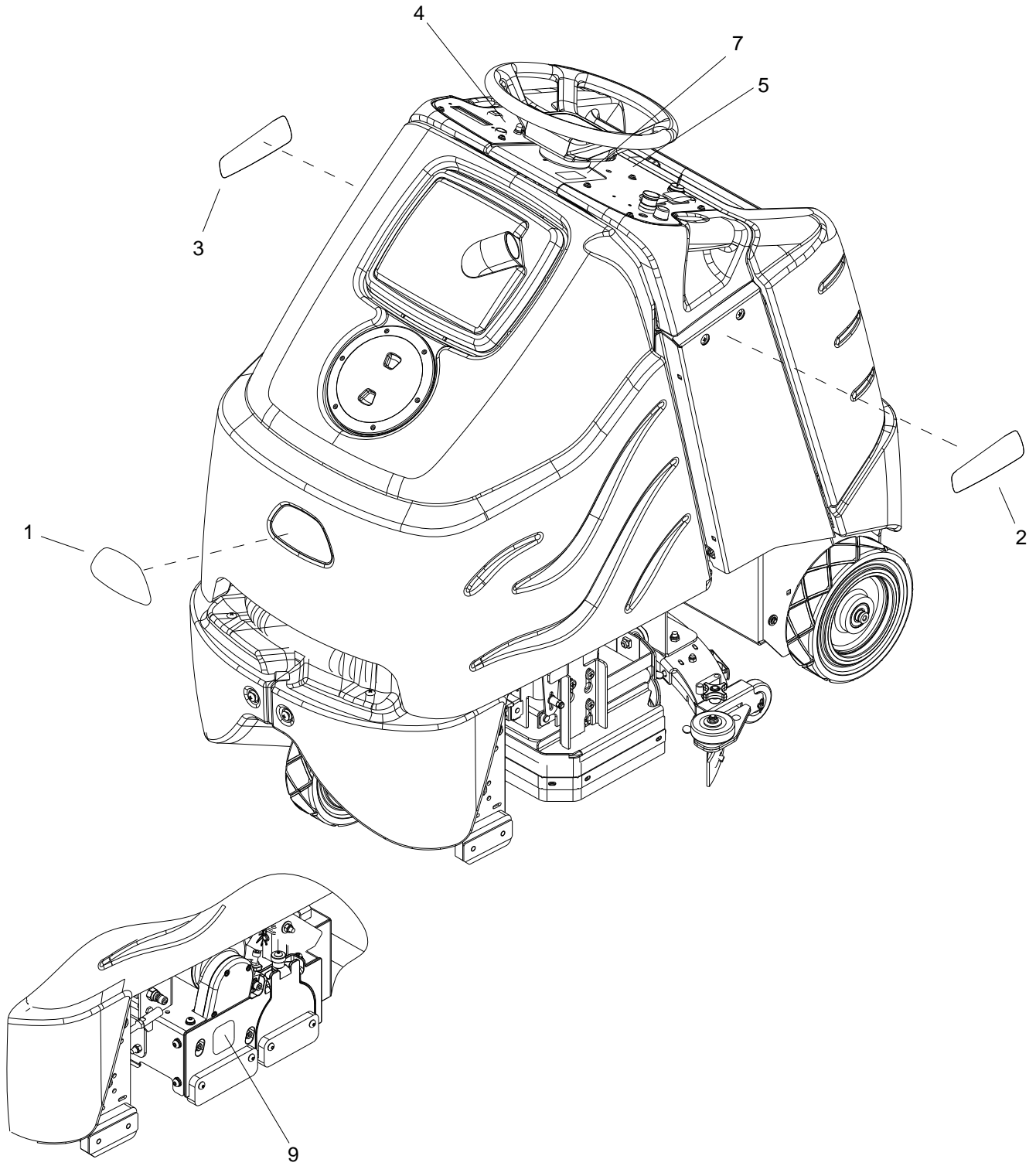

DECAL

REF	PART NO.	PRV NO.	QTY	DESCRIPTION	SERIAL NO. FROM	NOTES:
1	86004970	50990	1	LABEL, WINDSOR LOGO DOMED		
2	86244740	501222	1	DECAL, CHARIOT, ISCRUB RT		WAS 500884
3	86244750	501223	1	DECAL, CHARIOT, ISCRUB LT		WAS 500885
4A	86244200	500883	1	LABEL, PANEL BASIC RIGHT		
4B	86244180	500881	1	LABEL, PANEL DLX RIGHT		
5A	86244190	500882	1	LABEL, PANEL BASIC LEFT		
5B	86244170	500880	1	LABEL, PANEL DLX LEFT		
6	OPEN					
7	86243990	500780	1	LABEL, COVER PANEL		
8	OPEN					
9	86298970	-	1	LABEL, CLEAN BRUSHES AND DECK		CYLINDRICAL ONLY

NOTE: See "SAFETY LABEL LOCATION" page for safety label information.

FRAME-LOWER

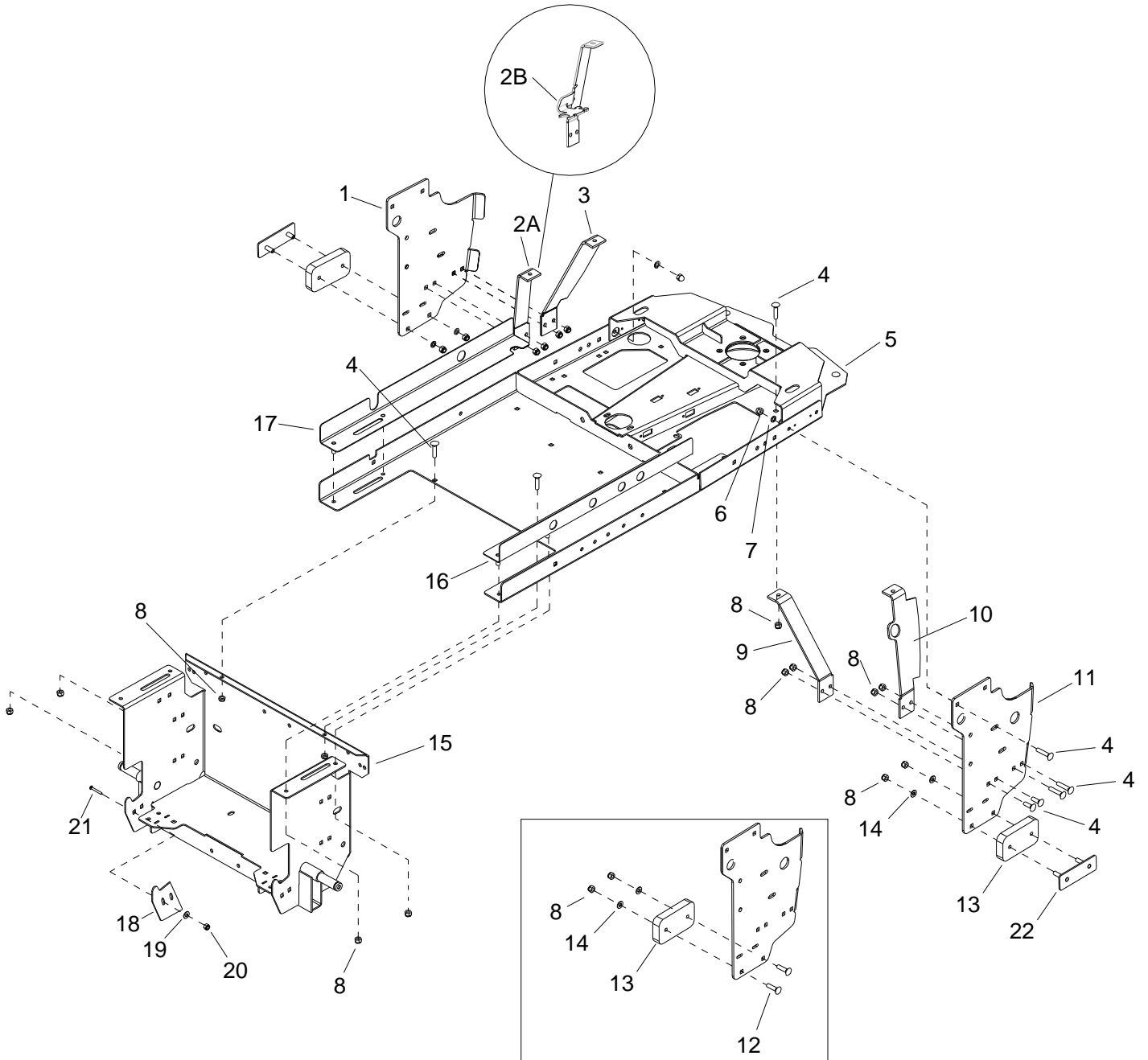

FRAME-LOWER

REF	PART NO.	PRV NO.	QTY	DESCRIPTION	SERIAL NO. FROM	NOTES:
1	86070750	140731	1	BRKT, TIP BAR LEFT		
2A	86071130	140812	1	BRKT, TIP BRACE, LEFT, REAR		CYLINDRICAL ONLY
2B	86303720	-	1	BRKT, BRACE, LT. REAR SOL		DISK ONLY
3	86070760	140733	1	BRKT, TIP BRACE, LEFT		
4	86276070	70593	16	SCR, 5/16-18 X 3/4 CARRIAGE SS		
5	86092500	34428	1	FRAME, MAIN		
6	86197040	57264	4	NUT, 5/16-18 HEX ACORN PLTD		
7	86279130	87083	4	WASHER, 5/16 SPLIT LOCK PLTD		
8	86270830	57023	16	NUT, 5/16-18 HEX NYLOCK SS		
9	86071120	140811	1	BRKT, TIP BRACE, LEFT, REAR		
10	86071430	140863	1	BRKT, BRACE RIGHT FRONT		
11	86070740	140730	1	BRKT, LINKAGE, RIGHT		
12	86277470	70848	4	SCR, 5/16-18 X 1.5 CARRIAGE SS		
13	86064300	140790	2	PAD, TIPPING BAR		
14	86010670	87029	4	WASHER, 5/16 FLAT SS		
15	86091420	05251	1	AXLE, REAR WELDMENT		
16	86088760	75458	1	TRAY, SLIDE, LEFT		
17	86088750	75457	1	TRAY, SLIDE, RIGHT		
18	86079290	620097	2	PLATE, REAR COVER ADJ	*(6)	
19	86010630	87013	4	WASHER, 1/4 ID X 5/8 OD SS	*(6)	
20	86271870	57290	4	NUT, 1/4-20 HEX NYLOCK THIN SS	*(6)	
21	86276950	70772	4	SCR, 1/4-20 X 3/4 CARRIAGE SS	*(6)	
22	86079320	620101	2	PLATE, PAD RETAINER	*(7)	

* SEE SERIAL NUMBER PAGE.

** CALL MANUFACTURER FOR SERIAL NUMBER

FRAME-UPPER

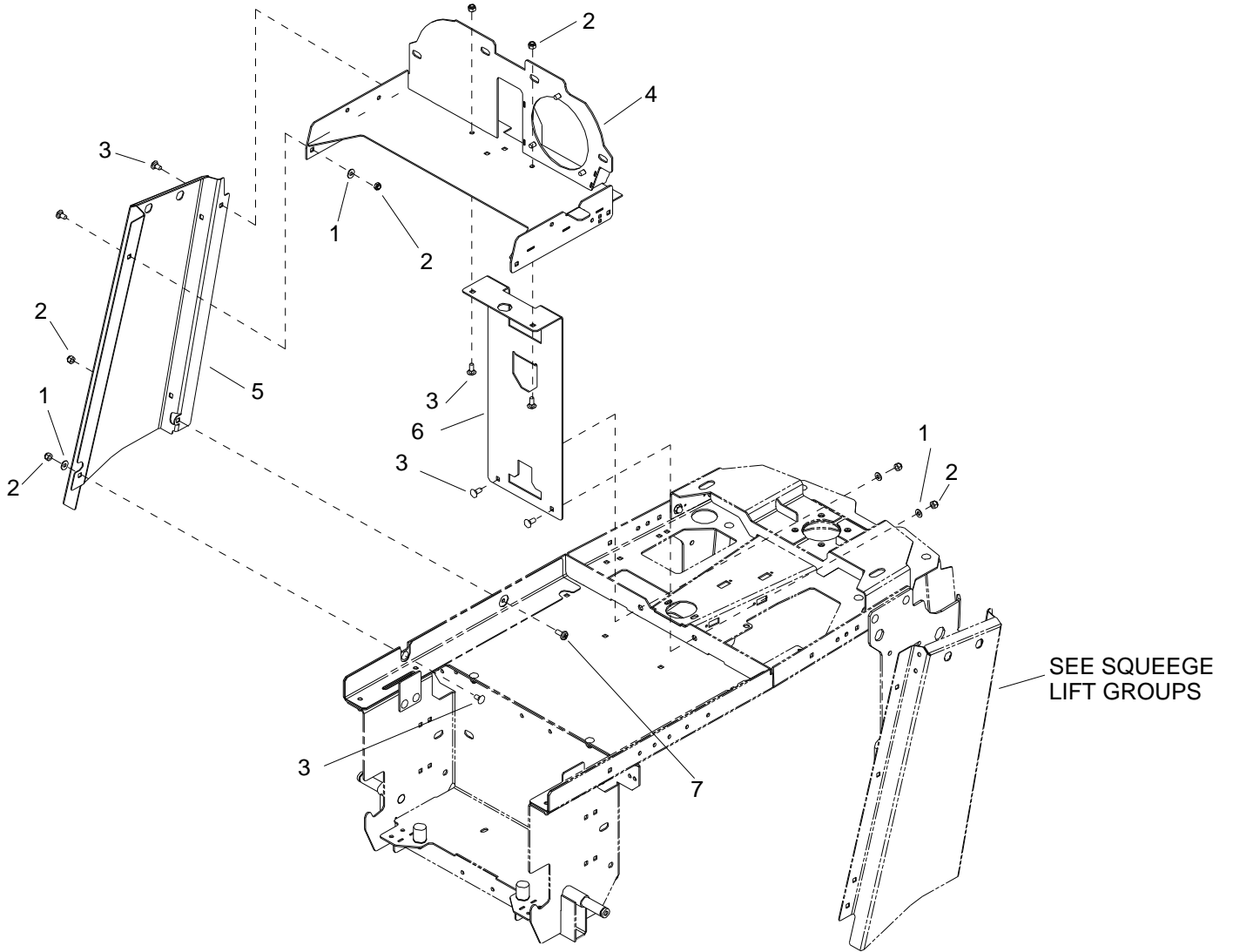

FRAME-UPPER

REF	PART NO.	PRV NO.	QTY	DESCRIPTION	SERIAL NO. FROM	NOTES:
1	86010670	87029	5	WASHER, 5/16 FLAT SS		
2	86270830	57023	8	NUT, 5-16-18 HEX NYLOCK SS		
3	86276070	70593	7	SCR, 5-16-18 X 3/4 CARRIAGE SS		
4	86091750	140727	1	BRKT, HORIZ ELECT		
5	86073500	270090	1	BRKT, SIDE CHANNEL L		
6	86083080	66437	1	PLATE, VERT BEARING SUPPORT		
7	86277460	70847	1	SCR, 5/16-18 X 5/8 BSHCS SS		

PEDAL PLATFORM

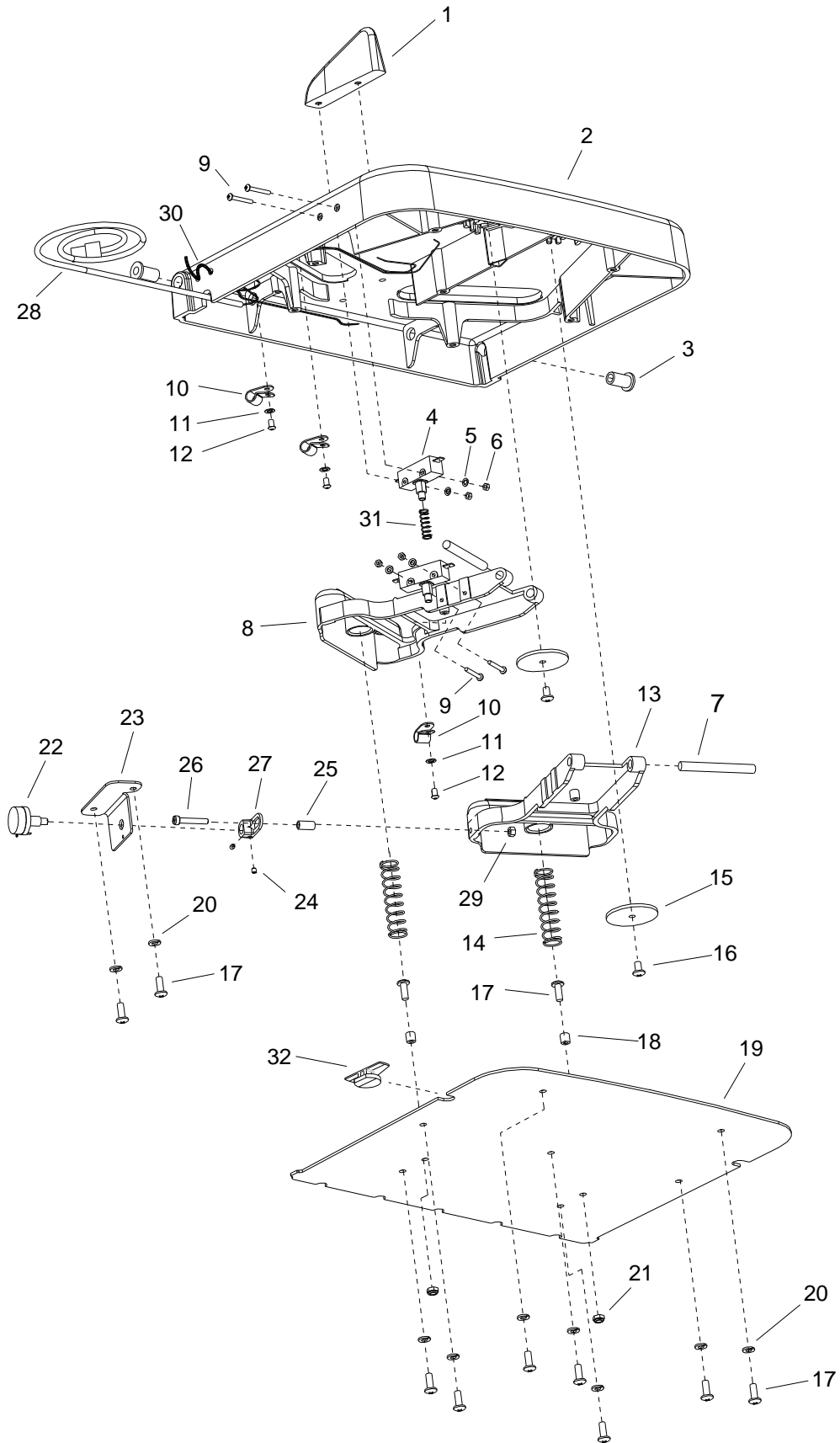

PEDAL PLATFORM

REF	PART NO.	PRV NO.	QTY	DESCRIPTION	SERIAL NO. FROM	NOTES:
1	86217650	34432	1	DIVIDER		
2	86222700	34429	1	PLATFORM		
3	86216380	140713	2	BUSHING, 8MM X 10LG CLY		
4	86007110	72123	2	SWITCH, 25A SPST 125-250V SNAP		
5	86279720	87248	4	WASHER, M4 INT STAR		
6	86272040	57503	4	NUT, M3.5 X 2.8 HEX		
7	86223580	67502	2	ROD, PIVOT, 8.5MM X 77		
8	86222520	34431	1	PEDAL, BRAKE		
9	86277390	70836	4	SCR, M3.5 X 38 PHMS		
10	86233170	20054	3	CLAMP, 3/8 NYLON UL/CSA		
11	86279730	87249	4	WASHER, M5 INT STAR		
12	86277380	70835	4	SCR, M4.8 X 16 PHTF		
13	86222510	34430	1	PEDAL, THROTTLE		
14	86254970	730304	2	SPRING, COMP 18MM OD X 83 X 2		
15	86222780	620047	2	PLATE, PIVOT		
16	86277360	70833	2	SCR, M6 X 10 PH		
17	86274340	70179	11	SCR, M6 X 16 PH		
18	86224360	730325	2	SPACER 12.7MM ID X 2.78W X 6L		
19	86222810	620050	1	PLATE, COVER		
20	86279140	87085	9	WASHER, M6 SPLIT LOCK DIN127B		
21	86288720	57277	2	NUT, M6 NYLOCK PLATED		
22	86250280	66135	1	POTENTIOMETER, 5K OHMS		
23	86222790	620048	1	PLATE, THROTTLE		
24	86278060	70759	2	SET SCR, M4 X 4MM NP		
25	86224350	730305	1	SPACER, 8MM 16L		
26	86277370	70834	1	SCR, M5 X 30 SHCS		
27	86221850	34433	1	LINK, THROTTLE		
28	86218810	23717	1	HARNESS, TWISTER PEDAL		
29	86316310	57086	1	NUT, M5 HEX		
30	86264920	27049	1	CABLE TIE, 7" UL/CSA		
31	86224750	73993	1	SPRING, COMP, .480D X .91	*(16)	
32	86223260	66085	1	PLUNGER, PLATFORM SWITCH	*(16)	

NOTE: Complete platform assembly is available, Part No. 86028310

*SEE SERIAL NUMBER PAGE.

PEDAL PLATFORM

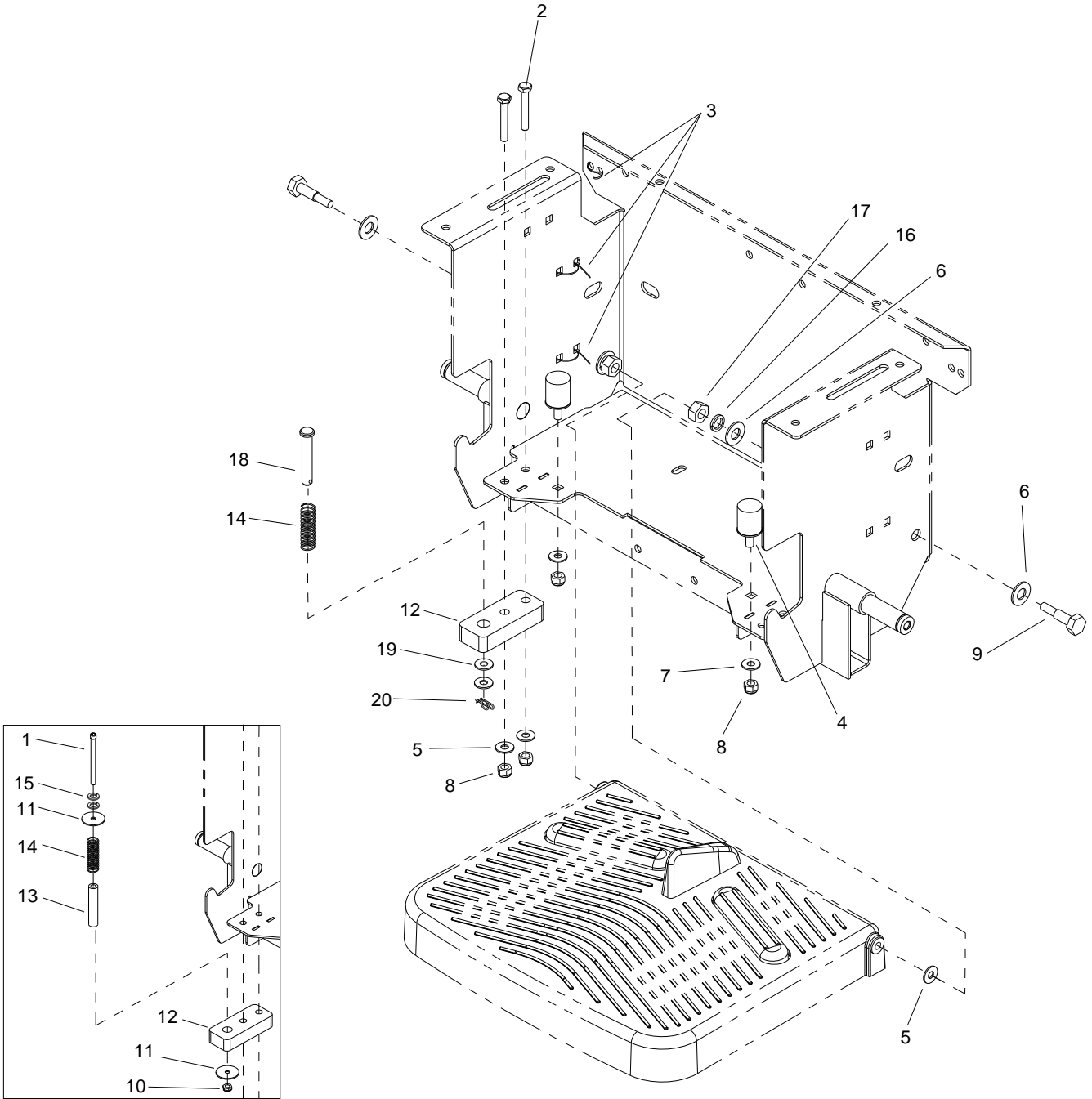

PEDAL PLATFORM

REF	PART NO.	PRV NO.	QTY	DESCRIPTION	SERIAL NO. FROM	NOTES:
1	86277430	70843	1	SCR, 1/4-20 X 3.00 SHCS		
2	86274690	70258	2	SCR, 5/16-18 X 1.5 HHCS GR5PLT		
3	86264920	27049	3	CABLE TIE, 7" UL/CSA		
4	86231070	730328	2	BUMPER, 1 X 1.375 RUBBER		
5	86010670	87029	5	WASHER, 5/16 FLAT SS		
6	86259430	87485	4	M12 FLAT WASHER		
7	86010770	87143	2	WASHER, 7/16ID X1D.08 FLT SS		
8	86270830	57023	4	NUT, 5/16-18 HEX NYLOCK SS		
9	86256470	70852	2	STUB AXLE, M12-1.75 X 45MM		
10	86005810	57245	1	NUT, 1/4-20 HEX NYLOCK SS		
11	86010810	87191	2	WASHER, 1/4" IDX1.0OD FLAT SS		
12	86064480	629993	1	PLATE, SWITCH BASE		
13	86286580	47479	1	SPACER, ACTUATOR SWITCH		WAS 730334
14	86007780	73576	1	SPRING, COMP .60D X2.0L X .045W		
15	86279760	87256	2	WASHER, 1/4 LOCK HICOLLAR PLT		
16	86259440	87486	2	WASHER, M12 SPRING LOCK		
17	86271190	57142	2	NUT, M12 X 1.75 HEX DIN934 PLT		
18	86248920	66487	1	PIN, CLEVIS 1/2 X 2.25	*(16)	
19	86278850	80613	2	WASHER, .506 ID X .94D X .064 NYL	*(16)	
20	86008680	80607	1	COTTER, 1/2" RING	*(16)	

*SEE SERIAL NUMBER PAGE.

REAR COVER

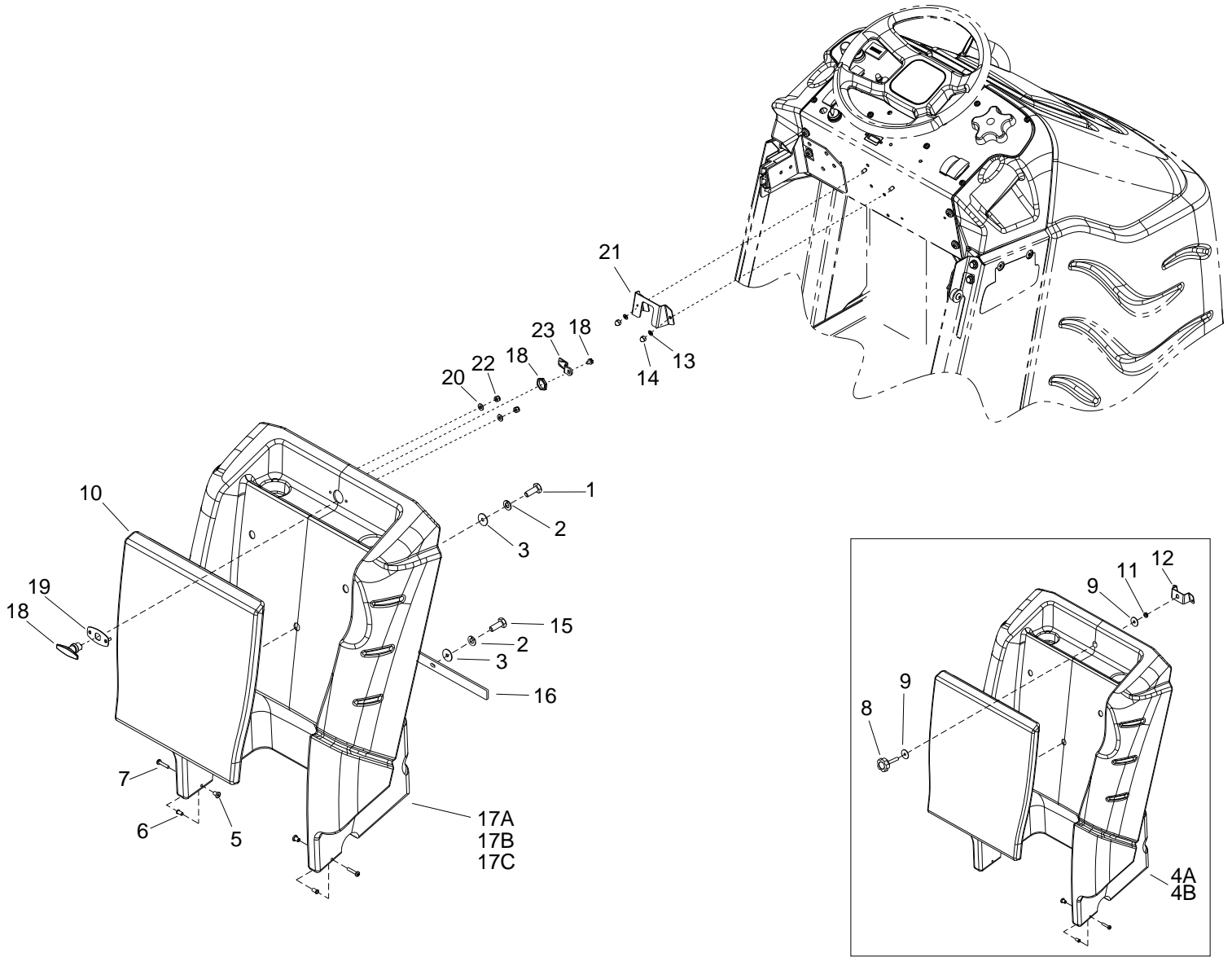

REAR COVER

REF	PART NO.	PRV NO.	QTY	DESCRIPTION	SERIAL NO. FROM	NOTES:
1	86276780	70728	3	SCR, 5/16-18 X 3/4 HHCS SS		
2	86279130	87083	5	WASHER, 5/16 SPLIT LOCK PLTD		
3	86010670	87029	5	WASHER, 5/16 FLAT SS		
4A	86031790	270701	1	COVER, REAR, BASIC		
4B	86031780	270082	1	COVER, REAR, DELUXE		
5	86005860	57273	2	NUT, 1/4-20 X 12MM HEX BARREL		
6	86228980	09152	2	BEARING FLANGED .377ID X .505OD		
7	86275870	70556	2	SCR, 1/4-20 X 1.5" PPHMS SS		WAS 70697
8	86242140	72193	1	KNOB, 3/8-16 X 1.5		
9	86010770	87143	2	WASHER, 7/16ID X 1D X .08FLT SS		
10	86248380	66433	1	PAD, FLAT LEANING		
11	86005630	57022	1	NUT, 3/8-16 HEX NYLOCK THIN SS		
12	86071030	140786	1	BRKT, ASSEMBLY, REAR COVER		
13	86010780	87162	2	WASHER, 1/4 SPLIT LOCK		
14	86271940	57299	2	NUT, 1/4-20 ACORN SS		
15	86006560	70083	2	SCR, 5/16-18 X 1 HHCS SS		
16	86066940	140891	1	BAR, COVER		
17A	86324660	-	1	REAR COVER, BASIC	*(34)	
17B	86324320	-	1	REAR COVER, DELUXE	*(34)	
17C	86324740	-	1	REAR COVER, ORG, DELUXE	*(34)	
18	86324640	-	1	HANDLE, CAM LATCH	*(34)	
19	86324760	-	1	PLATE, COVER LATCH	*(34)	
20	86010630	87013	2	WASHER, 1/4 ID X 5/8 OD SS	*(34)	
21	86324340	-	1	BRKT, REAR COVER	*(34)	
22	86005810	57245	2	NUT, 1/4-20 HEX NYLOCK SS	*(34)	
23	86324650	-	1	PAWL, HANDLE	*(34)	

*See Serial Number Page

SCRUB BRUSH/PAD DRIVER

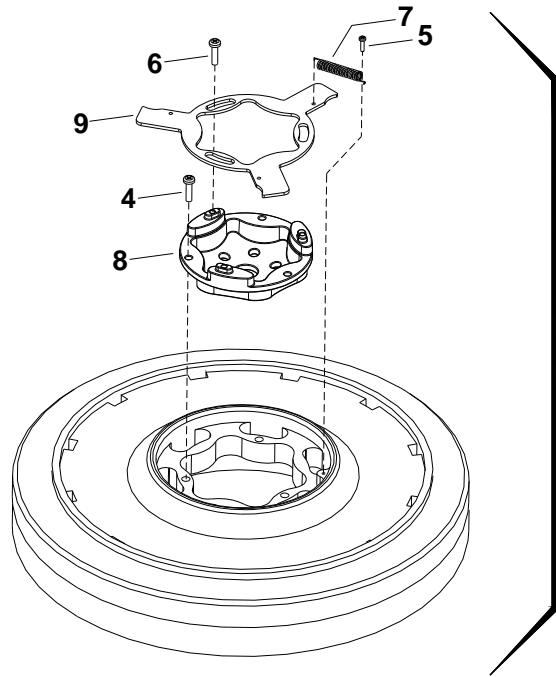
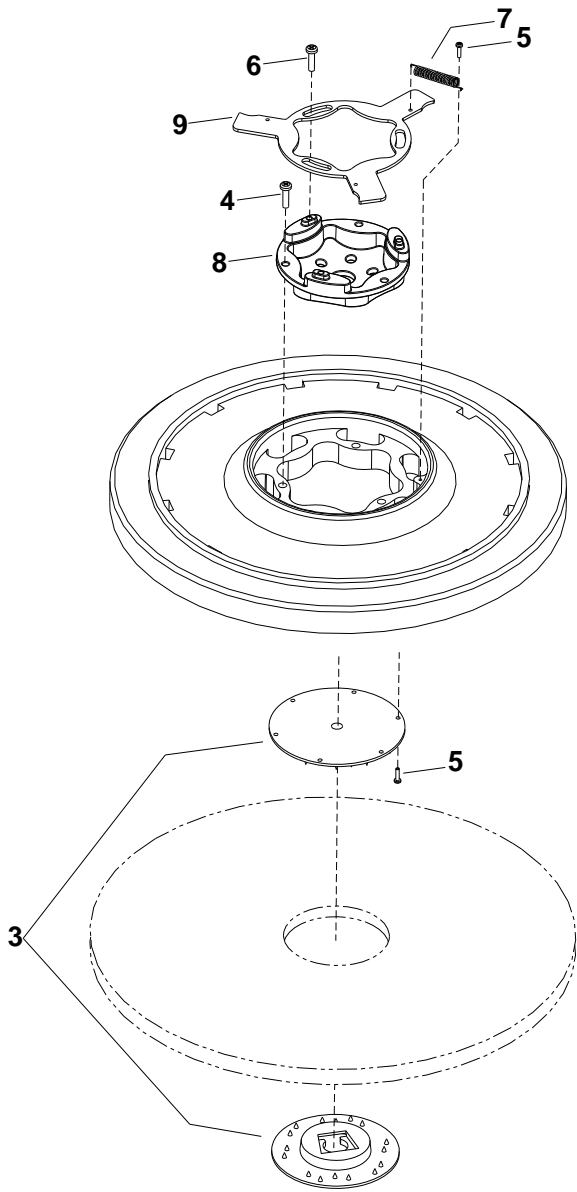

2A
2B
2C
2D

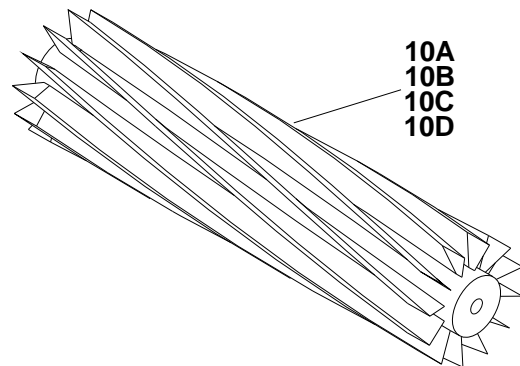

SCRUB BRUSH/PAD DRIVER

REF	PART NO.	PRV NO.	QTY	DESCRIPTION	SERIAL NO. FROM	NOTES:
1	86000170	02400	2	PAD DRIVER, 12" SD		
2A	86000180	02401	2	BRUSH, 12" POLYPROPYLENE SD		
2B	86000190	02402	2	BRUSH, 12" NYLON SD		
2C	86000200	02404	2	BRUSH, 12" MILD GRIT SD		
2D	86283820	02405	2	BRUSH, 12" SUPER AGG SD		
3	86005070	51284	1	LOCK, PAD CENTER SNAP, TWO STEP		
4	86276590	70695	3	SCR, #12 X 1 PPHSMS SS		
5	86276580	70694	1	SCR, 8-32 X 3/4 PTHMS		
6	86276600	70696	3	SCR, #10 X 3/4 PTHSMS SS		
7	86007910	73817	1	SPRING, EXT .31 D X 2.0 L X .03 W SS		
8	86007280	730011	1	SOCKET, DRIVE BRUSH		
9	86005940	62852	1	PLATE, BRUSH RELEASE		
10A	86283890	02500	2	BRUSH, 24" CYL, H-POLYP		
10B	86283900	02501	2	BRUSH, 24" CYL, H-NYLON		
10C	86283910	02502	2	BRUSH, 24" CYL, STCD GRIT		
10D	86283920	02503	2	BRUSH, 24" CYL, SUP AGR		

SCRUB DECK – DISK

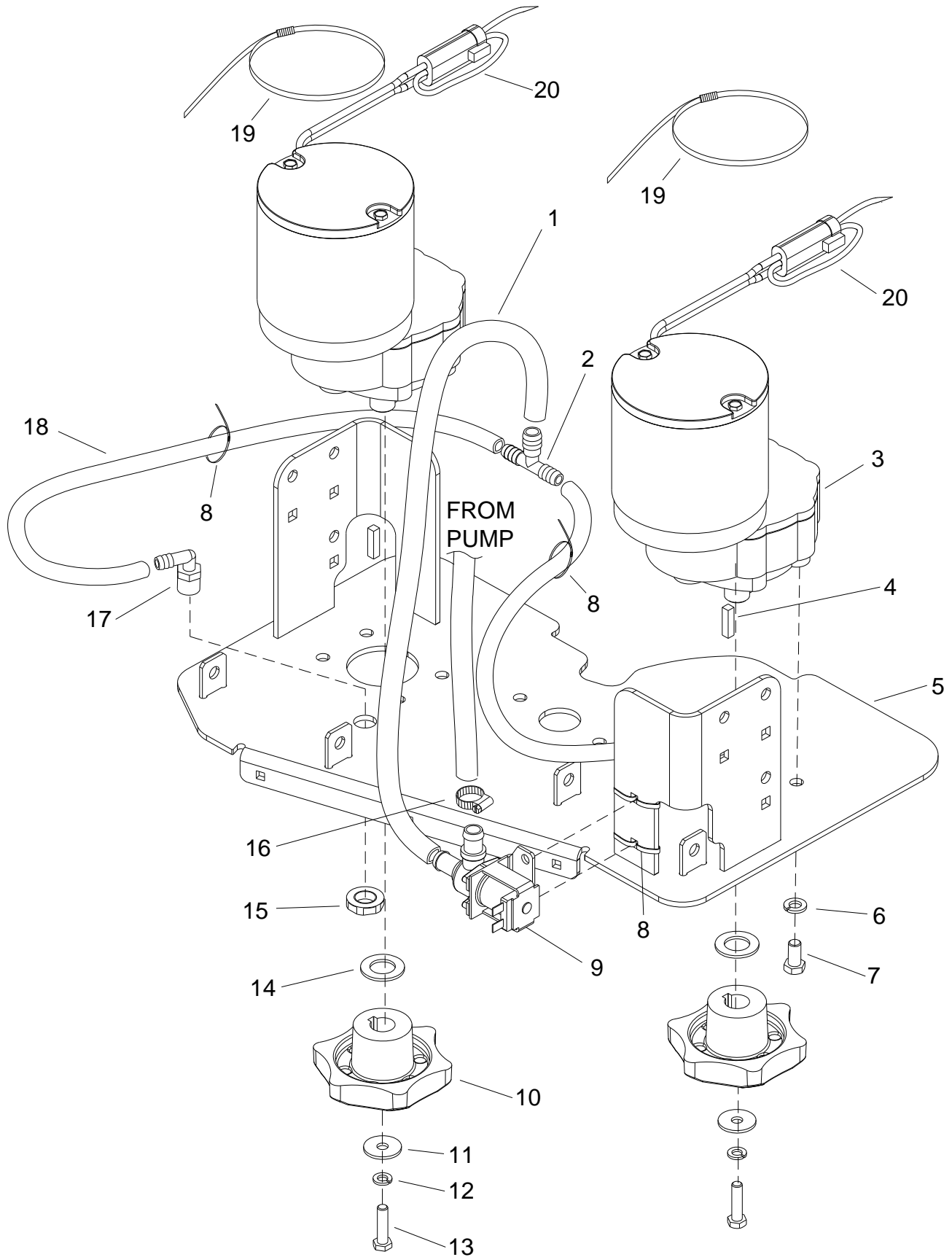

SCRUB DECK – DISK

REF	PART NO.	PRV NO.	QTY	DESCRIPTION	SERIAL NO. FROM	NOTES:
1	86281100	39274	1	HOSE, 1/2ID WIRE BOUND X 8"		
2	86003580	34327	1	FITTING, 1/2"X3/8"X3/8" RED		
3	86005490	53808	2	MOTOR ASM, 36VDC300RPM GEAR		
-	86216200	14739	-	BRUSH SET MOTOR 53808		
4	86004810	48040	2	KEY, 1/4 SQ X 1.00		
5	86093990	730330	1	SCRUBDECK, 24IN		
6	86010790	87163	8	WASHER, 3/8 SPLIT LOCK PLTD		
7	86276970	70774	8	SCR, 3/8-16 X 3/4 HHCS SS		
8	86264920	27049	6	CABLE TIE, 7" UL/CSA		
9	86010600	84199	1	VALVE, SOLENOID, 36VDC, 1/2 BARB		
-	86003460	29260	-	DIAPHRAGM, SRVC PART SLND		SERVICE ONLY
-	86136820	47395	-	SERVICE SLND SPRG KIT		SERVICE ONLY
10	86003420	29220	2	DRIVER, BRUSH SD		
11	86279630	87212	2	WASHER, .344IDX1.130DX.09T PLT		
12	86279130	87083	2	WASHER, 5/16 SPLIT LOCK PLTD		
13	86007020	70673	2	SP SCR, 5/16-18 X 1.25 HHCS SS NP		
14	86279530	87173	2	WASHER, .765IDX1.310DX.09T SS		
15	86271830	57283	2	NUT, 3/8 NPT PLASTIC		
16	86233150	20042	1	CLAMP, 3/8 HOSE (D-SLOT)		
17	86004470	40043	2	HOSEBARB, 3/8MPT X 3/8 90D		
18	86281310	39326	2	HOSE, 3/8ID WIREBOUND X 8"		
19	86002830	27196	2	CABLE TIE, .375 X 24.7		
20	86264940	27051	2	CABLE TIE, 11.38" UL/CSA		

SCRUB DECK – CYLINDRICAL

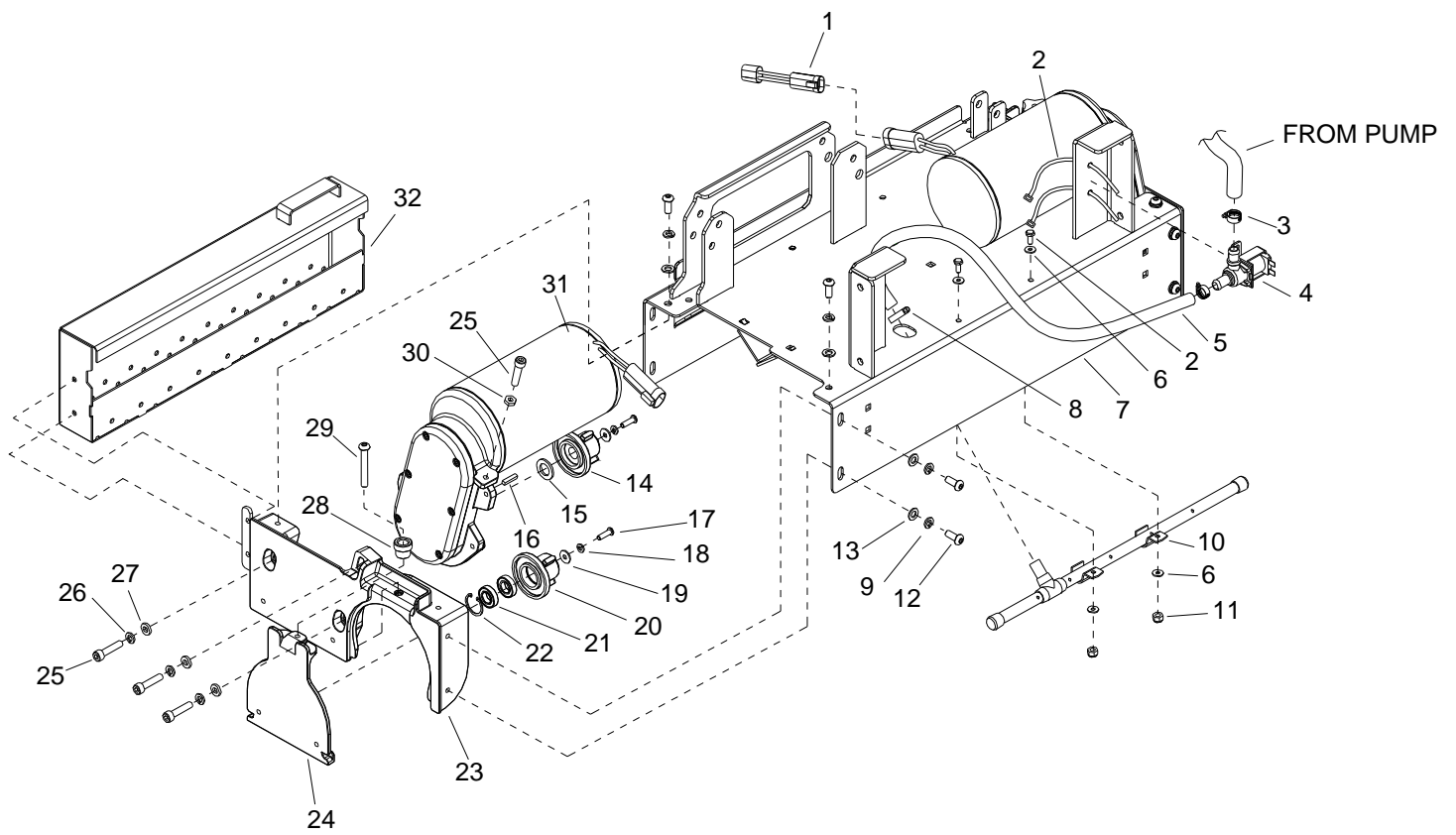

SCRUB DECK - CYLINDRICAL

REF	PART NO.	PRV NO.	QTY	DESCRIPTION	SERIAL NO. FROM	NOTES:
1	86260400	880212	2	WIRE ASM, REV POLARITY JUMPER		
2	86273750	70011	4	SCR, 1/4-20 X 5/8 HHCS SS NP		
3	86233150	20042	2	CLAMP, 3/8 HOSE (D-SLOT)		
4	86010600	84199	4	VALVE, SOLENOID, 36VDC, 1/2 BARB		
5	86282330	39715	1	HOSE, 5/8 ID WIREBOUND X 16"		
6	86010630	87013	4	WASHER, 1/4 ID X 5/8 OD SS		
7	86092520	34441	1	FRAME, SCRUB DECK 24		
8	86233270	20093	2	CLAMP, 7/8" WORM GEAR SS		
9	86279130	87083	12	WASHER, 5/16 SPLIT LOCK PLTD		
10	86233070	20003	2	CLAMP, 1/2 DIA THINWALL CONDUIT		
11	86005810	57245	2	NUT, 1/4-20 HEX NYLOCK SS		
12	86277530	70861	12	SCR, M8 X 1.25 X 20 LG BSHCS SS		
13	86010670	87029	12	WASHER, M8 FLAT DIN125A PLT		
14	86219440	41487	2	HUB, TRI-STAR BRUSH DRIVE		
15	86279780	87488	2	WASHER, M16 SMALL OD FLAT PLTD		
16	86004820	48041	2	KEY, 3/16 SQ X 7/8 CRS		
17	86277870	70854	4	SCREW, M6-1.0 X 20 LG BHSCS SS		
18	86279140	87085	4	WASHER, M6 SPLIT LOCK DIN127B		
19	86279770	87487	4	WASHER, M6 LARGE OD FLAT PLTD		
20	86219450	41488	2	HUB, TRI-STAR BRUSH IDLER		
21	86228960	09149	4	BEARING, BALL 15MM X 28MM X 7W		
22	86223520	67598	2	RING, 28MM INTERNAL SNAP		
23	86219290	34418	2	HOUSING, SCRUB PLUS DRIVE		
24	86217710	29268	2	DOOR, CYLINDRICAL BRUSH		
25	86277880	70855	8	SCREW, M8-1.25 X 35 LG SHCS SS		
26	86137310	87098	6	WASHER, M8 SPLIT LOCK		
27	86279790	87489	6	WASHER, M8 (THICK) FLAT PLTD		
28	86242120	48090	2	KNOB, 1.0 OD X 5-16-18		
29	86277150	70797	2	SCR, 5-16-18 X 2 BSHCS SS		
30	86222330	57504	2	NUT, M8 X 1.25 HEX JAM SS		
31	86222110	53267	2	MOTOR, SP BRUSH DRIVE, 36V, 3/4HP		
-	86001360	140394	-	BRUSH SET		SRVC ONLY
-	86218170	35369	-	GASKET, GEARBOX		
32	86092840	41535	1	HOPPER, CYL, DECK		
33	86264940	27051	3	CABLE TIE, 11.38" UL/CSA		

SCRUB DECK AQUA-MIZER™

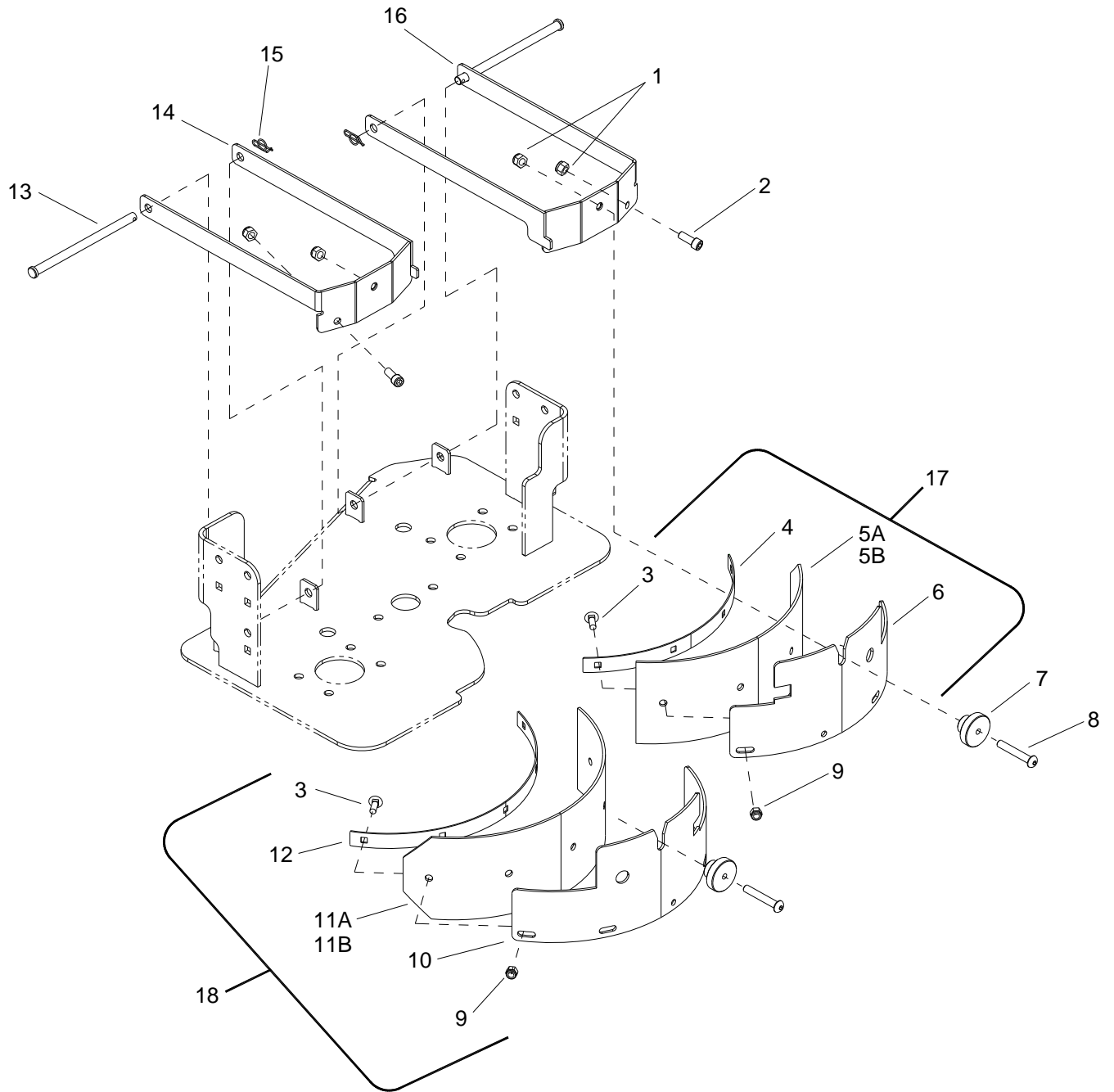

SCRUB DECK AQUA-MIZER™

REF	PART NO.	PRV NO.	QTY	DESCRIPTION	SERIAL NO. FROM	NOTES:
1	86270830	57023	4	NUT, 5/16-18 HEX NYLOCK SS		
2	86277050	70782	2	SCR, 5/16-18 X 3/4 SHCS		
3	86276950	70772	9	SCR, 1/4-20 X 3/4 CARRIAGE SS		
4	86066430	140747	1	BAND, RIGHT AQUAMIZER		
5A	86001540	140753	1	BLADE, AQUAMIZER, 12IN RGT		
5B	86283550	140939	1	BLADE, AQMZR 12 RT URETHANE		
6	86071000	140779	1	BRKT, AQUAMIZER BLADE, RGT		
7	86219690	48080	2	KNOB, 1.5 OD X 5/16-18		
8	86277230	70815	2	SCR, 5/16-18 X 2.25 BSHCS SS		
9	86005810	57245	9	NUT, 1/4-20 HEX NYLOCK SS		
10	86070990	140778	1	BRKT, AQUAMIZER BLADE, LEFT		
11A	86001520	140752	1	BLADE, AQUAMIZER, 12IN LEFT		
11B	86283560	140940	1	BLADE, AQMZR 12 LT URETHANE		
12	86066420	140746	1	BAND, LEFT AQUAMIZER		
13	86272540	66465	2	PIN, CLEVIS, 3/8 X 6.12, PLTD		
14	86091800	140776	1	BRKT, AQUAMIZER MTG, LEFT		
15	86008670	80606	2	COTTER, 3/8" RING		
16	86091790	140774	1	BRKT, AQUAMIZER MTG, PIVOT		
17	86024990	47456	-	AQUAMIZER RIGHT ASM. CHARIOT		
18	86025000	47457	-	AQUAMIZER LEFT ASM. CHARIOT		

SIDE SQUEEGEE – CYLINDRICAL

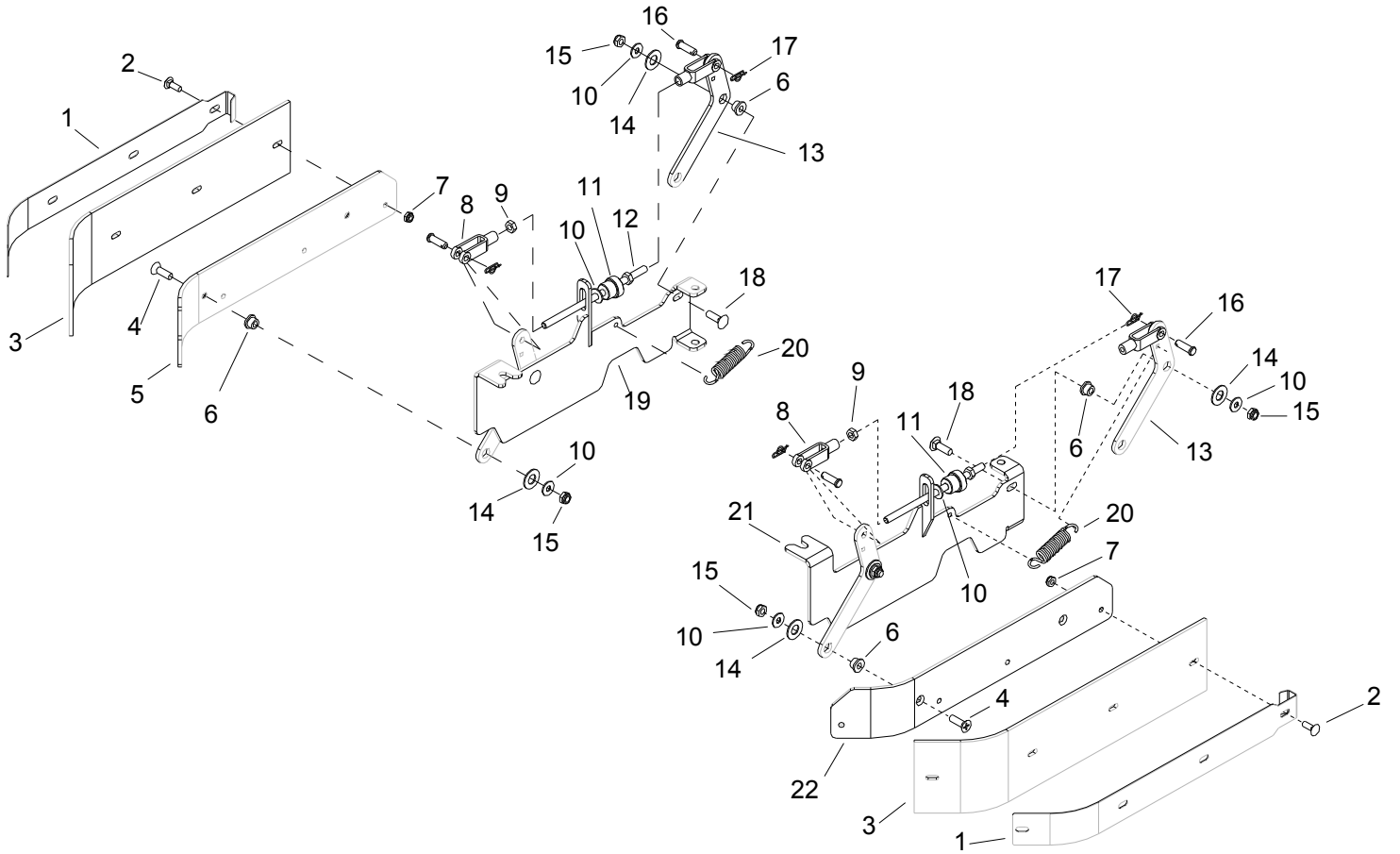

SIDE SQUEEGEE - CYLINDRICAL

REF	PART NO.	PRV NO.	QTY	DESCRIPTION	SERIAL NO. FROM	NOTES:
1	86066510	140838	2	BAND, SIDE SQG, 24		
2	86276950	70772	8	SCR, 1/4-20 X 3/4 CARRIAGE SS		
3	86283480	140039	2	BLADE, SQUEEGEE, SIDE, 24		
4	86277120	70792	4	SCR, 5/16-18 X 1 PFHMS SS		
5	86071340	140848	1	BRKT, SKIRT, SQG, LH		
6	86228990	09153	8	BEARING, FLNGD, .314 ID X .502 OD		
7	86271870	57290	8	NUT, 1/4-20 HEX NYLCK THIN SS		
8	86226430	80636	4	CLEVIS, 5/16" YOKE END 5/16-18		
9	86271170	57138	4	NUT, 5/16-18 JAM		
10	86010670	87029	10	WASHER, 5/16 FLAT SS		
11	86242120	48090	2	KNOB, 1.0 OD X 5/16-18		
12	86086570	67600	1	ROD, 5/16-18 X 6.5 ADJ		
13	86079160	620071	4	PLATE, SQG LINKAGE ARM		
14	86259420	87232	8	WASHER, THRUST .51 ID X 1 OD BRO		
15	86271840	57285	8	NUT, 5/16-18 HEX NYLOCK THIN SS		
16	86272550	66485	4	PIN, CLEVIS, 5/16 X 1.00 PLTD		
17	86008660	80605	4	COTTER, 5/16" RING		
18	86277130	70795	4	SCR, 5/16-18 X 1.00 CARRIAGE SS		
19	86091600	140061	1	BRKT, SIDE SQG, WELDMENT, LH		
20	86226830	73268	2	SPRING, EXT .68 D X 3.00 L X .098 W		
21	86091570	140021	1	BRKT, SIDE SQG, WELDMENT, RH		
22	86071280	140836	1	BRKT, SKIRT, SQG, RH		

SCRUB DECK - SIDE SQUEEGEE - CYLINDRICAL

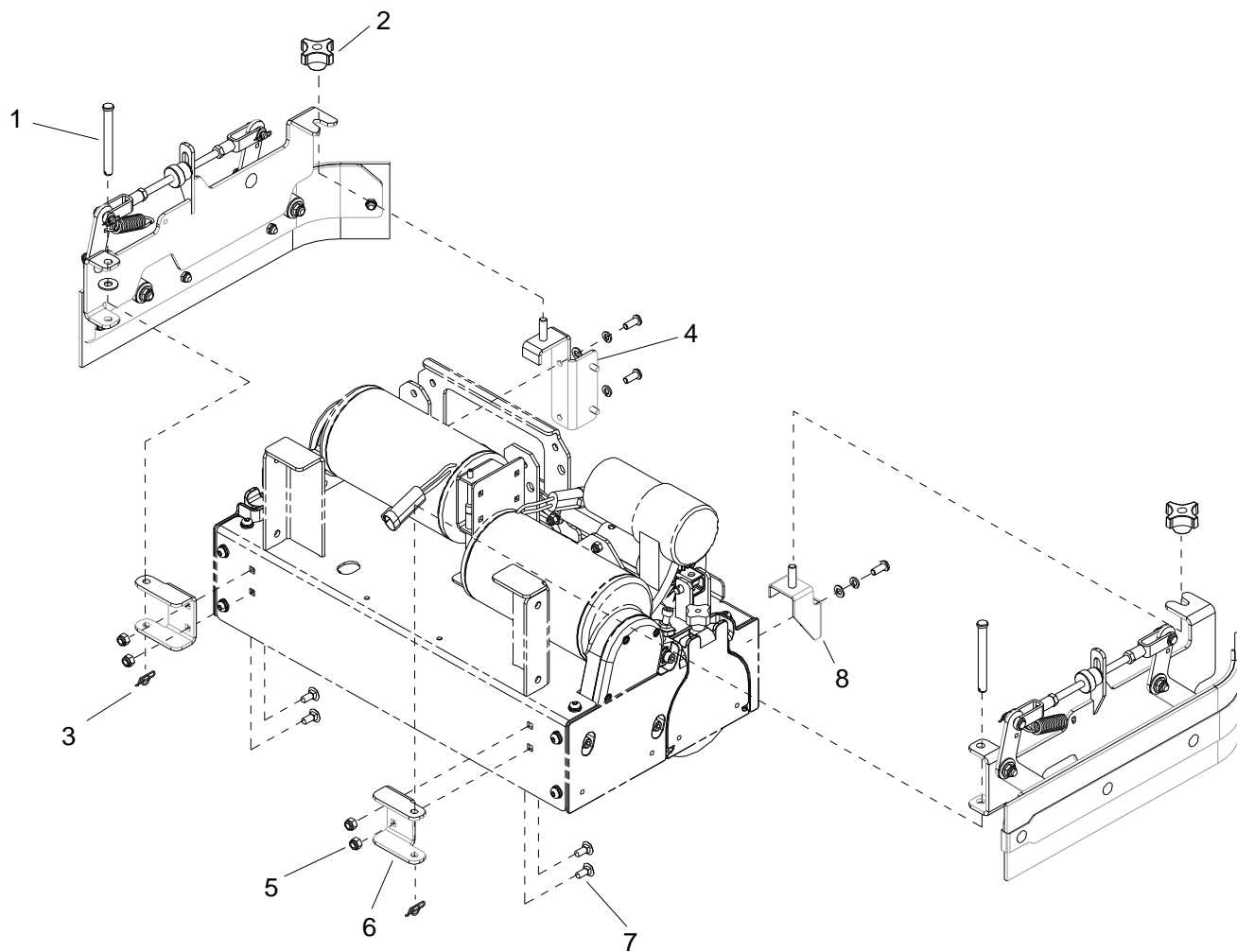

SCRUB DECK - SIDE SQUEEGEE - CYLINDRICAL

REF	PART NO.	PRV NO.	QTY	DESCRIPTION	SERIAL NO. FROM	NOTES:
1	86249050	82058	2	PIN, CLEVIS 3/8 X 3.50 PLTD		
2	86009200	81535	2	KNOB, 3/8-16 4 PRONG ALUM		
3	86008670	80606	2	COTTER, 3/8" RING		
4	86068570	140050	1	BRKT, HOPPER ALIGNMENT		
5	86270830	57023	4	NUT, 5/16-18 HEX NYLOCK SS		
6	86071350	140849	2	BRKT, SIDE SQG MOUNT		
7	86276070	70593	4	5/16-18 X 3/4 CARRIAGE SS		
8	86071440	140864	1	BRKT, SIDE SQUEEGEE, LFT		

SCRUB DECK SKIRTS

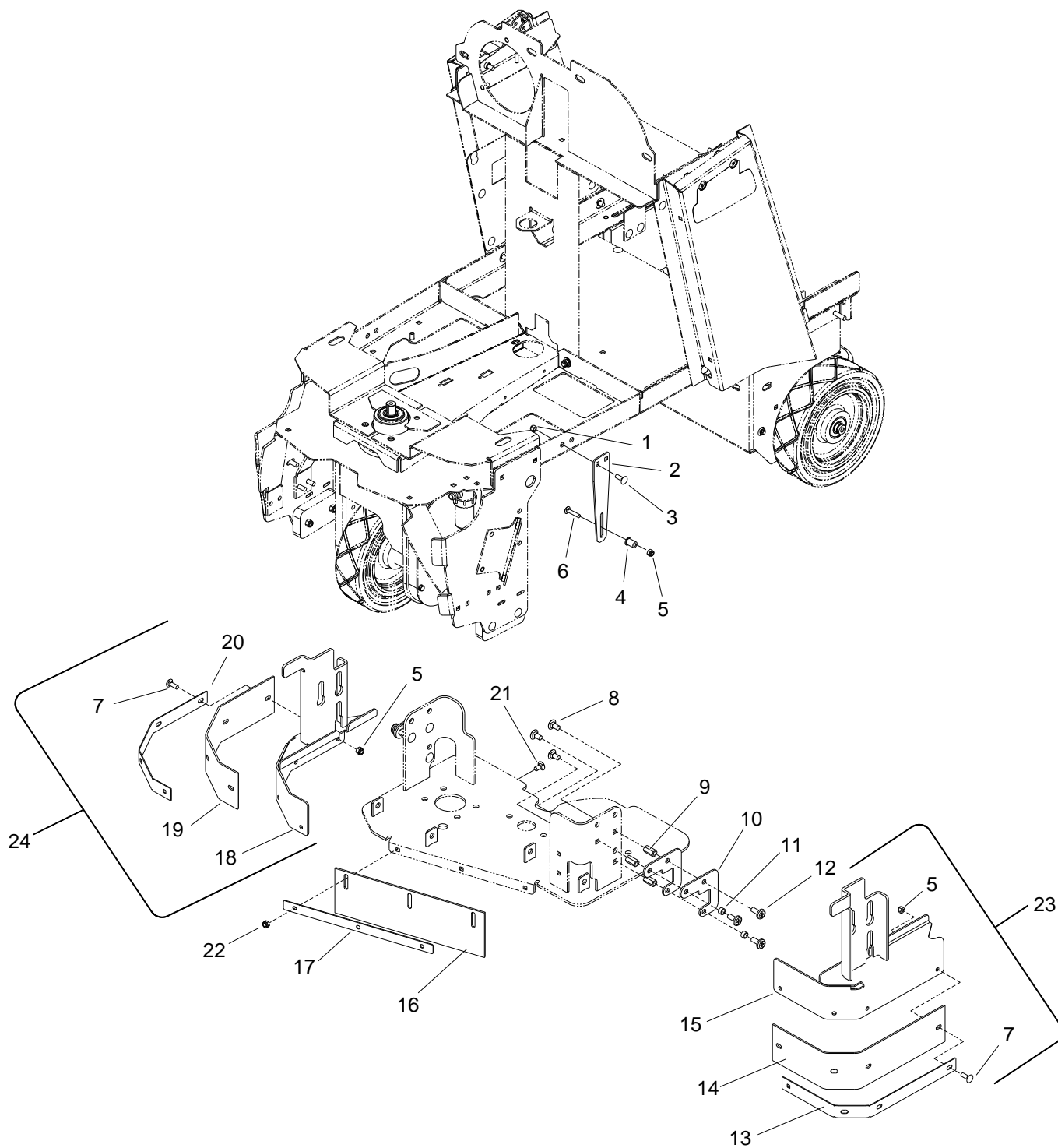

SCRUB DECK SKIRTS

REF	PART NO.	PRV NO.	QTY	DESCRIPTION	SERIAL NO. FROM	NOTES:
1	86270830	57023	4	NUT, 5/16-18 HEX NYLOCK SS		
2	86070960	140773	2	BRKT, SKIRT STOP, SCRUBDECK		
3	86276070	70593	4	SCR, 5/16-18 X 3/4 CARRIAGE SS		
4	86228900	09138	2	BEARING FLANGED, .252IDX.503OD		
5	86005810	57245	6	NUT, 1/4-20 HEX NYLOCK SS		
6	86276330	70634	2	SCR, 1/4-20 X 1.25 CARRIAGE BZ		
7	86276950	70772	8	SCR, 1/4-20 X 3/4 CARRIAGE SS		
8	86277410	70840	6	SCR, 5/16-18 X 5/8 CARRIAGE SS		
9	86271950	57300	6	NUT, 5/16-18 X 1 COUPLING SS		
10	86079130	620068	4	PLATE, SKIRT, SPACER		
11	86007650	730329	4	SPACER, .438D X .317ID X .25L		
12	86007070	70849	6	SCR, 5/16-18 X 1.00 PTMS SS		
13	86066460	140769	1	BAND, SKIRT, LEFT		
14	86001560	140754	1	BLADE, SKIRT, SCRBDCK, 24IN LFT		
15	86091770	140765	1	BRKT, SKIRT SCRUBDECK, LEFT		
16	86001700	140780	1	BLADE, SKIRT, SCRUBDECK, FRONT		
17	86066480	140781	1	BAND, SKIRT, SCRUBECK, FRONT		
18	86091780	140766	1	BRKT, SKIRT, SCRUBDECK, RIGHT		
19	86001570	140755	1	BLADE, SKIRT, SCRBDCK, 24IN RGT		
20	86066470	140770	1	BANC, SKIRT, RIGHT		
21	86277500	70853	3	SCR, 1/4-20 X 5/8 CARR SS		
22	86271870	57290	3	NUT, 1/4-20 HEX NYLOCK THIN SS		
23	86026470	47459	-	KIT, SKIRT LEFT		SERVICE ONLY
24	86026460	47458	-	KIT, SKIRT RIGHT		SERVICE ONLY

SCRUB DECK LIFT

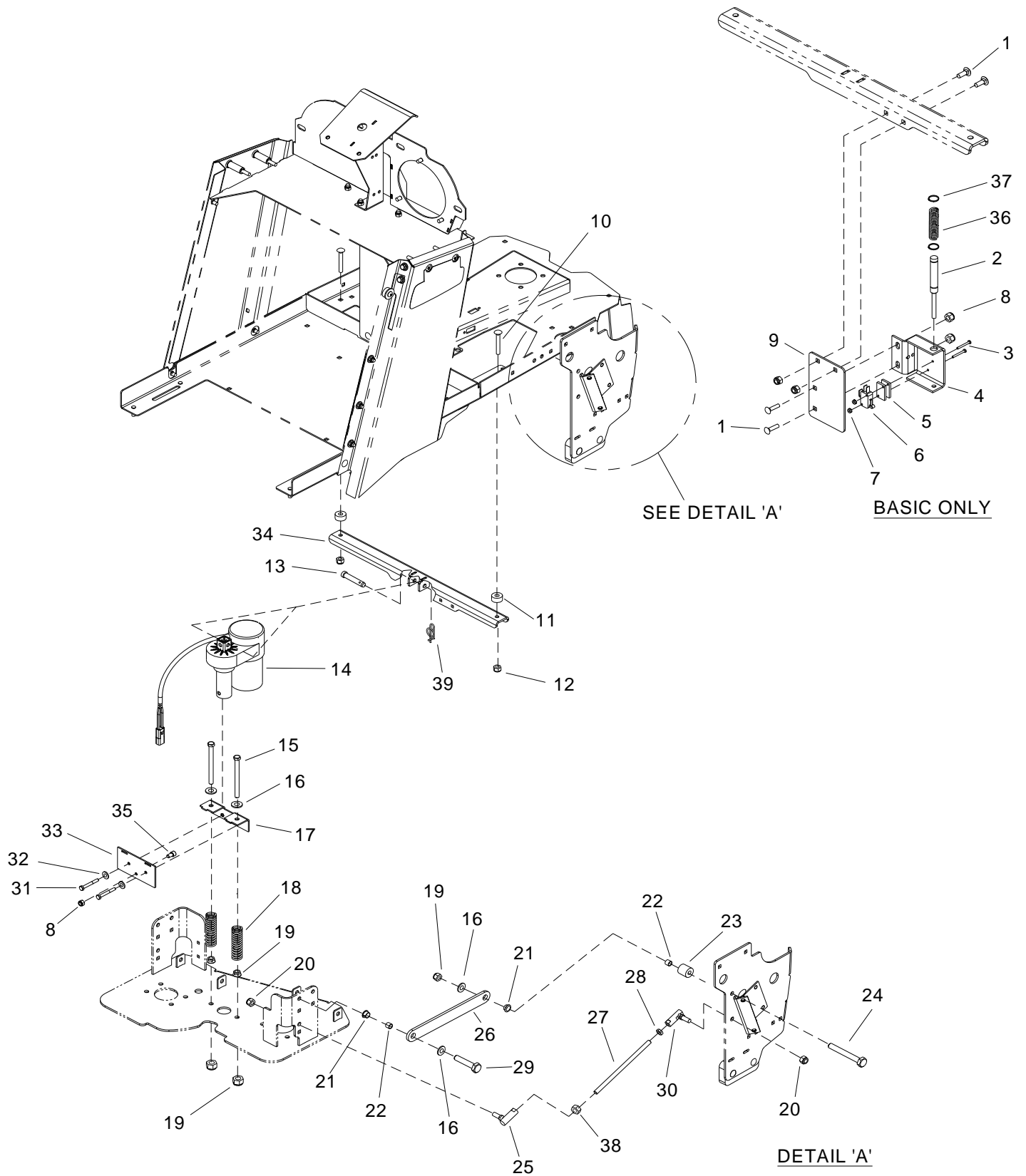

SCRUB DECK LIFT

REF	PART NO.	PRV NO.	QTY	DESCRIPTION	SERIAL NO. FROM	NOTES:
1	86276950	70772	4	SCR, 1/4-20 X 3/4 CARRIAGE SS		
2	86223270	66482	1	PLUNGER, MICRO SWITCH	*(13)	
3	86276010	70580	2	SCR, 4-40 X 1.0 PPHMS		
4	86072460	14387	1	BRKT, MICROSWITCH MOUNT		
5	86087520	73456	2	SPACER, L2020B PLUNGER SWITCH		
6	86007160	72157	1	SWITCH, 10A ROLLER MINI		
7	86271280	57163	2	NUT, 4-40 W/STAR WASHER		
8	86005810	57245	6	NUT, 1/4-20 HEX NYLOCK SS		
9	86079150	620070	1	PLATE, MTG, DECK LIMIT		
10	86277030	70780	2	SCR, 5/16-18 X 1.25 CARRIAGE SS		
11	86224370	730335	2	SPACER, 1 OD X .391 ID X .500		
12	86270830	57023	2	NUT, 5/16-18 HEX NYLOCK SS		
13	86272460	66268	1	PIN, CLEVIS 5/16 X 3.00 PLTD	*(26)(27)(28) (29)(30)	WAS 80637
-	86008720	80637	1	PIN, CLEVIS 3/8 X 2.38	*(22)	WAS 66369
14	86011950	-	1	ACTUATOR, 36VDC 3.5 STRK	*(21)	WAS 05250
15	86275510	70494	2	SCR, 3/8-16 X 4.5" HHCS GR5		
16	86010770	87143	2	WASHER, 7/16ID X IDX.08 FLT SS		
17	86070810	140739	1	BRKT, ACTUATOR SPGS, SCRUBDECK		
18	86255450	81376	2	SPRING COMP .96D X 4.0L X .135W		
19	86005630	57022	4	NUT, 3/8-16 HEX NYLOCK THIN SS		
20	86271530	57216	2	NUT, 3/8-24 HEX NYLOCK		
21	86009050	81324	6	BEARING, 1/2 ID X 11/32L NYLON		
22	86008460	80102	4	SPACER, .500OD X .391ID C .400		
23	86224380	730336	2	SPACER, 1 OD X 0.391 ID X 1.063		
24	86274010	70070	2	SCR, 3/8-16 X 2 HHCS		
25	86001320	140353	2	BALL JOINT ASSY, 3/8-24 LH		
26	86077330	31373	2	LINKAGE, .25 X 1.25 X 9.25		
27	86223540	66483	2	ROD, SCRUB LIFT	*(17)	
28	86005800	57217	2	NUT, 3/8-24 HEX JAM		
29	86276920	70755	2	SCR, 3/8-16 X 1 HHCS SS NP		
30	86008810	80697	2	BALL JOINT ASY, 3/8-24 RH		
31	86273850	70022	2	SCR, 1/4-20 X 2 HHCS		
32	86010780	87162	2	WASHER, 1/4 SPILT LOCK PLTD		
33	86079030	620058	1	PLATE, ACTUATOR SPR, SCRUBDECK		
34	86091760	140741	1	BRKT, ACTUATOR MTG, SCRUBBER		
35	86274110	70094	2	SCR, 1/4-20 X 1/2 SHCS		
36	86007780	73576	1	SPRING, COMP .60D X 2.0L X .045W		
37	86270270	27721	2	CLIP, RETAINING 7/16		
38	86005830	57263	2	NUT, 3/8-24 UNF LH		
39	86008660	80605	1	COTTER, 5/16" RING	*(26)(27)(28) (29)(30)	WAS 80606
-	86008670	80606	1	COTTER, 3/8" RING	*(22)	

* SEE SERIAL NUMBER PAGE

SCRUB DECK MOUNTING- CYLINDRICAL

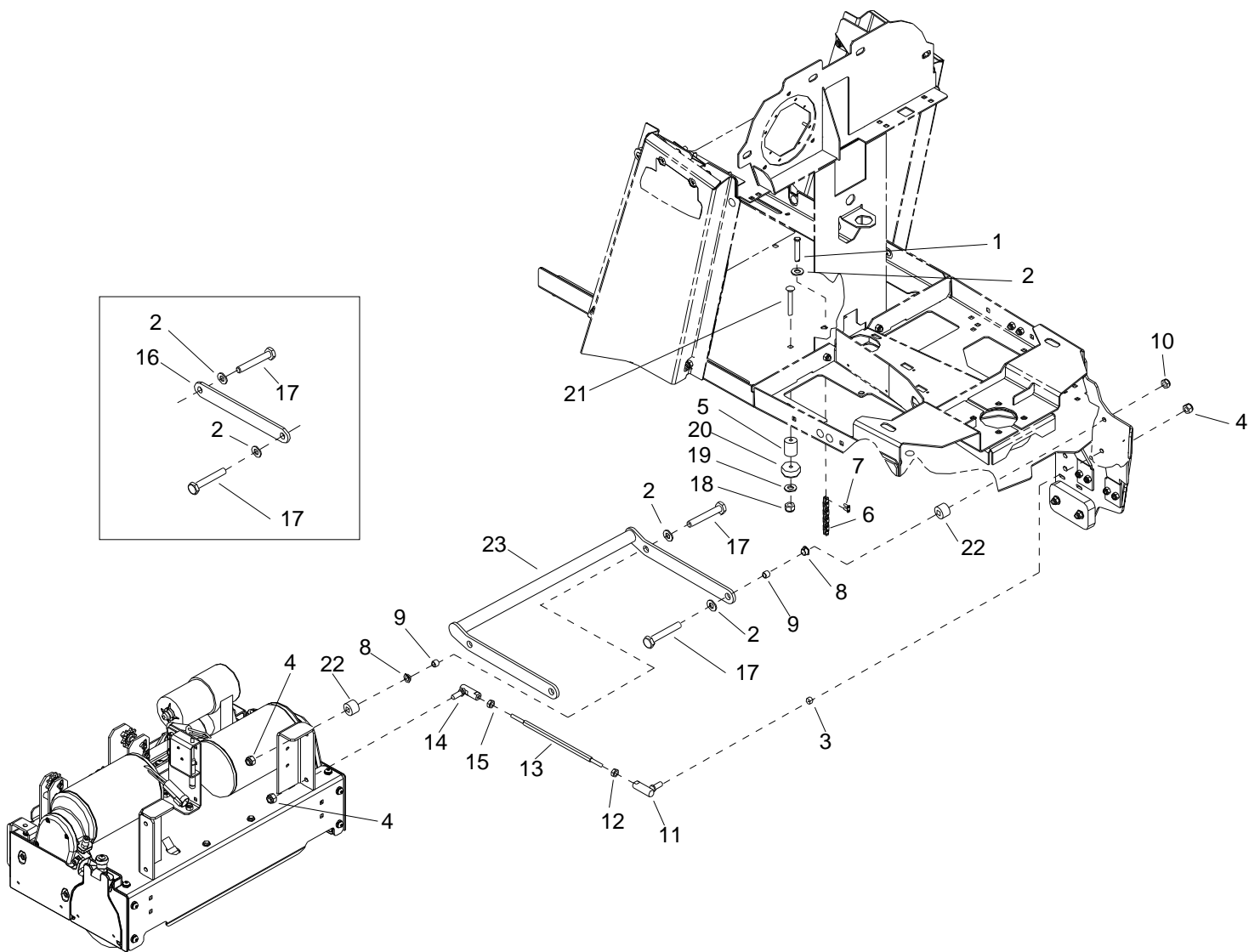

SCRUB DECK MOUNTING - CYLINDRICAL

REF	PART NO.	PRV NO.	QTY	DESCRIPTION	SERIAL NO. FROM	NOTES:
1	86272380	66217	1	PIN, CLEVIS 3/8 X .75 PLTD		
2	86010770	87143	5	WASHER, 7/16 ID X 1D X .08 FLT SS		
3	86087580	73606	2	SPACER, 1/2 OD X .058 ID X .26 LG CRS		
4	86271530	57216	6	NUT, 3/8-24 HEX NYLOCK		
5	86224380	730336	2	SPACER, 1 OD X .391 ID X 1.063		
6	86232680	270114	REF	CHAIN, #41, 1/2" PITCH X 34		
7	86009400	81873	1	CHAIN, #41, 1/2" P MASTER LINK		
8	86009050	81324	4	PIN, CLEVIS 3/8 X .75 UNPLTD		
9	86008460	80102	4	SPACER, .500 OD X .391 ID X .400		
10	86005630	57022	2	NUT, 3/8-16 HEX NYLOCK THIN SS		
11	86008810	80697	2	BALL JOINT ASY, 3/8-24 RH		
12	86005800	57217	2	NUT, 3/8-24 HEX JAM		
13	86223540	66483	2	ROD, SCRUB LIFT HEX		WAS 67415 ROUND
14	86001320	140353	2	BALL JOINT ASSY, 3/8-24 LH		
15	86005830	57263	2	NUT, 3/8-24 UNF LH		
16	86077330	31373	2	LINKAGE, .25 X 1.25 X 9.25		
17	86274660	70255	4	SCR, 3/8-16 X 1.5 HHCS GR5 PLTD		
18	86271840	57285	2	NUT, 5/16-18 HEX NYLOCK THIN SS		
19	86010670	87029	2	WASHER, 5/16 FLAT SS		
20	86231090	80809	2	BUMPER, RUBBER 5/16" ID X 1.50		
21	86276690	70715	2	SCR, 5/16-18 X 1.75 CARR SS		
22	86224370	730335	4	SPACER, 1 OD X .391 ID X .500 LG		
23	86093180	51415	1	LINKAGE ASM, DECK ARM	*(9)	

*SEE SERIAL NUMBER PAGE.

SCRUB DECK ACTUATOR - CYLINDRICAL

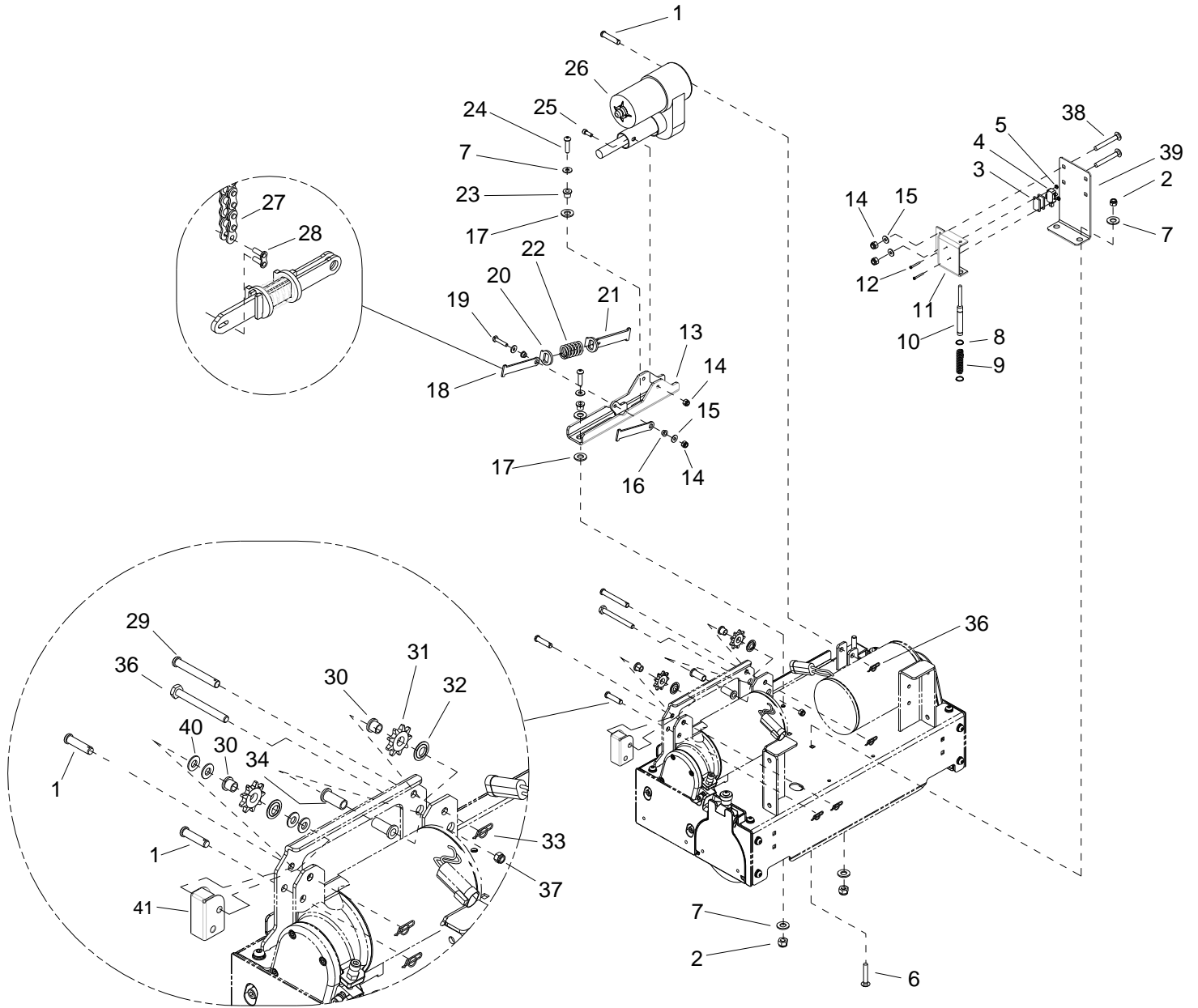

SCRUB DECK ACTUATOR - CYLINDRICAL

REF	PART NO.	PRV NO.	QTY	DESCRIPTION	SERIAL NO. FROM	NOTES:
1	86248980	81438	3	PIN, CLEVIS 3/8 X 1.75 PLTD		
2	86270830	57023	2	NUT, 5/16-18 HEX NYLOCK SS		
3	86087520	73456	2	SPACER, L2020B PLUNGER SWITCH		
4	86007160	72157	1	SWITCH, 10A ROLLER MINI		
5	86271280	57163	2	NUT, 4-40 W/STAR WASHER		
6	86276070	70593	2	SCR, 5/16-18 X 3/4 CARRIAGE SS		
7	86010670	87029	4	WASHER, 5/16 FLAT SS		
8	86270270	27721	2	CLIP, RETAINING 7/16		
9	86007780	73576	1	SPRING, COMP .60 D X 2.0 L X .045 W		
10	86223270	66482	1	PLUNGER, MICROSWITCH		
11	86072460	14387	1	BRKT, MICROSWITCH MOUNT		
12	86276010	70580	2	SCR, 4-40 X 1.0 PPHMS		
13	86091840	140850	1	BRKT, ACTUATOR SLIDER		
14	86005810	57245	5	NUT, 1/4-20 HEX NYLOCK SS		
15	86010630	87013	4	WASHER, 1/4 ID X 5/8 OD SS		
16	86231360	14744	2	BUSH, BRZ FLG .25 X .38 X .25		
17	86259420	87232	4	WASHER, THRUST .51 ID X 1 OD BRO		
18	86066910	140851	2	BAR, COMP. SPRING RETAINER, OS		
19	86273820	70019	1	SCR, 1/4-20 X 1.25 HHCS SS		
20	86090330	87258	2	WASHER, .804 ID X 1.25 OD X .179		
21	86066920	140852	1	BAR, COMP. SPRING RETAINER, IS		
22	86278400	730351	1	SPRING, COMP., 1.1 OD X 2.25 L X .148		
23	86228840	09124	2	BEARING, FLANGED .314 ID X .502 OD		
24	86276760	70724	2	SCR, 5/16-18 X 1.25 BSHCS SS		
25	86006910	70443	2	SCR, 1/4-20 X 5/8 SHCS		
26	86011950	-	1	ACTUATOR, 36VDC, 3.5 IN STRK	*(21)	WAS 05250
27	86232680	270114	1	CHAIN, #41, 1/2" PITCH X 34D		
28	86009400	81873	1	CHAIN, #41, 1/2" MASTER LINK		
29	86272520	66392	1	PIN, CLEVIS 3/8 X 2.75 PLTD		
30	86229000	09154	2	BEARING FLG .377 ID X .502 OD X .501		
31	86255650	81627	2	SPROCKET, #41 1/2"P 9T		
32	86222270	57276	2	NUT, PUSH FLAT RD .51 ID		
33	86008670	80606	4	COTTER, 3/8" RING		
34	86228910	09139	2	BEARING, FLANGED .377 ID X .502 OD		
35	OPEN	-	-	-		
36	86276400	70642	1	SCR, 3/8-16 X 3 HHCS SS		
37	86005630	57022	1	NUT, 3/8-16 HEX NYLOCK THIN SS		
38	86277500	70853	2	SCR, 1/4-20 X 5/8 CARR SS		
39	86071450	140865	1	BRKT, STRIKER		
40	86010680	87030	4	WASHER, 3/8 ID X 3/4 OD NYLON		
41	86290090	-	1	GUARD, CHAIN	*(1)	

*SEE SERIAL NUMBER PAGE.

SOLUTION - CYLINDRICAL

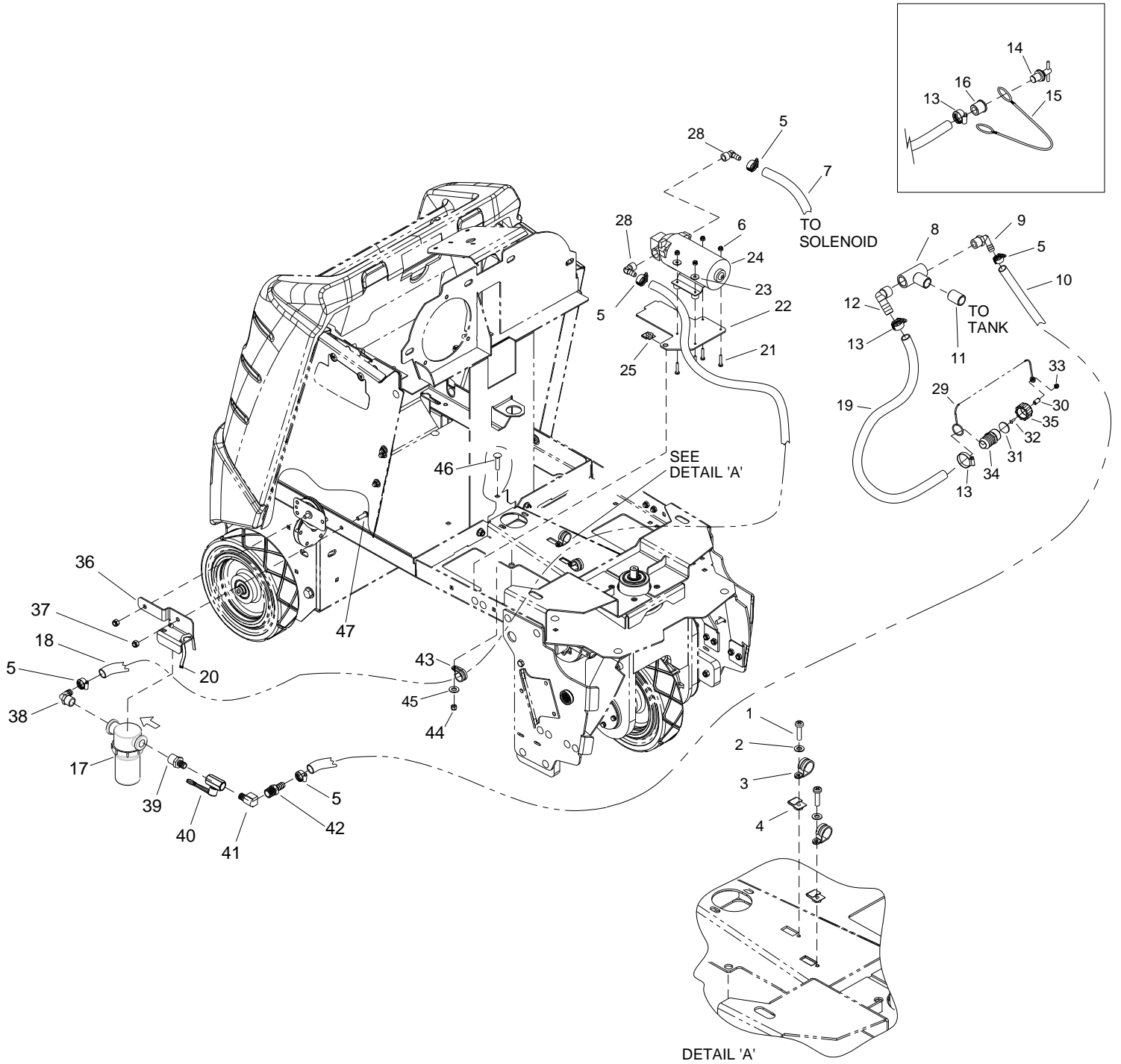

SOLUTION- CYLINDRICAL

REF	PART	PRV NO.	QTY	DESCRIPTION	SERIAL NO.	NOTES:
1	86274070	70086	2	SCR, 10-24 X 1/2 PPHMS		
2	86010650	87018	2	WASHER, #10 X 9/16 OD		
3	86233390	80887	2	CLAMP, 7/8 DIA "P" CUSHIONED		
4	86270860	57028	2	NUT, 10-24 U-TYPE SPEED		
5	86233150	20042	5	CLAMP, 3/8 HOSE (D-SLOT)		
6	86270990	57090	4	NUT, 10-32 HEX NYLOCK SS		
7	86282320	39710	1	HOSE, 1/2ID WIRE BOUND X 49"		
8	86198050	81923	1	TEE, 3/4 FPT		
9	86240390	40075	1	HOSEBARB, 3/4 MPT X 1/2 90D		
10	86280910	39174	1	HOSE, 1/2ID WIRE BOUND X 23"		
11	86247760	80960	1	NIPPLE, 3/4 CLOSE PVCE		
12	86240600	41526	1	HOSEBARB, 3/4 MPTX1, HOSE 90DEG		
13	86233110	20018	2	CLAMP, 1.00" WORM GEAR		
14	86009700	82267	1	PLUG, 5/8" DRAIN HOSE		
15	86270510	51457	1	LANYARD, .093 X 6 NYLON		WAS 78499
16	86001600	40076	1	SLEEVE, .63 ID X 1.0 OD		
17	86256120	730368	1	STRAINER, 1/2 FPT 100 MESH		
-	86005870	59021	-	O-RING, FILTER SEAL RON-VIK		SERVICE ONLY
-	86136800	73839	-	SCREEN, 80 MESH STRAINER DEEP		SERVICE ONLY
18	86282370	39735	1	HOSE, 1/2ID WIRE BOUND X 40"		
19	86004310	39505	1	HOSE, 1.0 X 18.0 DRAIN		
20	86264920	27049	2	CABLE, TIE. 7" UL/CSA		
21	86274410	70195	4	SCR, 10-32 X 1.25 PPHMS SS		
22	86070690	140724	1	BRKT, SOLUTION PUMP		
23	86010650	87018	4	WASHER, #10 X 9/16 OD		
24	86006100	65176	1	PUMP ASM, 36V		
25	86271820	57270	1	NUT, 5/16-18 CAPTIVE "J" PLTD		
26	86279130	87083	1	WASHER, 5/16 SPLIT LOCK PLTD		
27	86276780	70728	1	SCR, 5/16-18 X 3/4 HHCS SS		
28	86197940	40027	2	HOSEBARB, 3/8MPTX1/2 90D DL		
29	86246090	51461	1	LANYARD, .093 X 6", LOOP - .26 EYE	*(11)	
30	86254320	730400	1	SPACER, .17 ID X .25 OD X 3/16 LG	*(11)	
31	86259450	87507	1	WASHER, 1.0 D X .1 THK, SEAL	*(11)	
32	86252730	70887	1	SCR, 8-32 X 1/2 BHCS SST	*(11)	
33	86248010	57312	1	NUT, 8/32 ACORN CAP, PLATED	*(11)	
34	86226950	40109	1	1" HOSEBARB X 3/4" GHT NYLON	*(11)	
35	86073960	22104	1	CAP, 3/4" GHT W/.17 HOLE	*(11)	
36	86068780	140202	1	BRKT, STRAINER MNT	*(25)	
37	86270830	57023	2	NUT, 5/16-18 HEX NYLOCK SS	*(25)	
38	86001530	40039	1	HOSE BARB, 1/2 MPT X 1/2 HOSE 90	*(25)	
39	86188210	11-800354	1	NIP, 1/2 X 3/8 HEX BR	*(25)	
40	86225680	84201	1	VALVE, 3/8" FPT BALL	*(25)	
41	86197420	31026	1	ELBOW, 3/8" NPT STREET	*(25)	
42	86197540	40013	1	HOSEBARB, 3/8 MPT X 1/2 DL	*(25)	
43	86233410	81270	1	CLAMP, 3/4 DIA CUSHION .406 DIA	*(25)	
44	86270830	57023	1	NUT, 5/16-18 HEX NYLOCK SS	*(25)	
45	86010670	87029	1	WASHER, 5/16 FLAT SS	*(25)	
46	86276070	70593	1	SCR, 5/16-18 X 3/4 CARRIAGE SS	*(25)	
47	86277460	70847	1	SCR, 5/16-18 X 5/8 BSHCS SS	*(25)	

*SEE SERIAL NUMBER PAGE.

SOLUTION - DISK

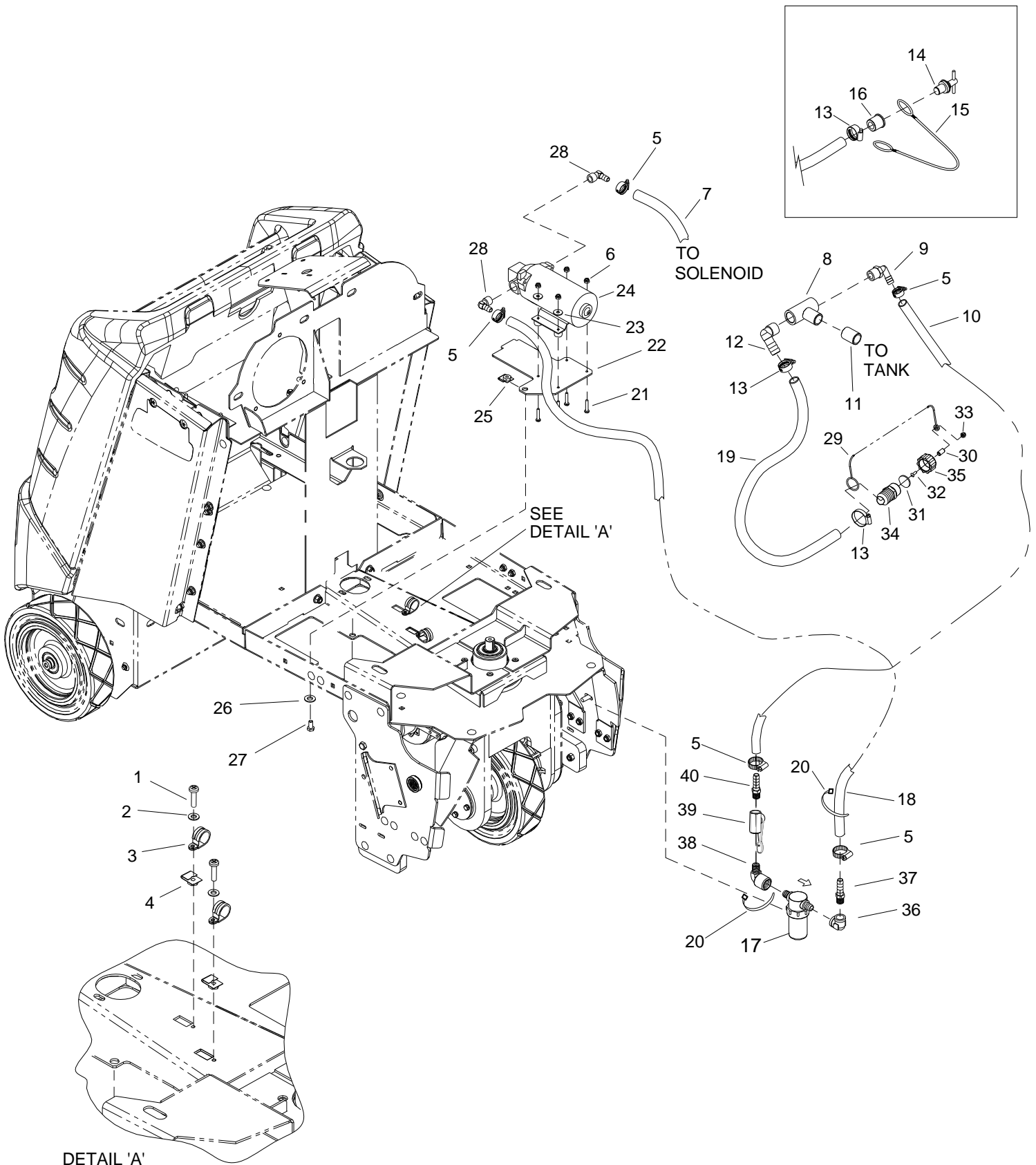

SOLUTION - DISK

REF	PART NO.	PRV NO.	QTY	DESCRIPTION	SERIAL NO. FROM	NOTES:
1	86274070	70086	2	SCR, 10-24 X 1/2 PPHMS		
2	86010650	87018	2	WASHER, #10 X 9/16 OD		
3	86233390	80887	2	CLAMP, 7/8 DIA "P" CUSHIONED		
4	86270860	57028	2	NUT, 10-24 U-TYPE SPEED		
5	86233150	20042	5	CLAMP, 3/8 HOSE (D-SLOT)		
6	86270990	57090	4	NUT, 10-32 HEX NYLOCK SS		
7	86281940	39540	1	HOSE, 1/2ID WIRE BOUND X 40"		
8	86198050	81923	1	TEE, 3/4 FPT		
9	86240390	40075	1	HOSEBARB, 3/4 MPT X 1/2 90D		
10	86282190	39616	1	HOSE, 1/2ID WIRE BOUND X 13"		
11	86247760	80960	1	NIPPLE, 3/4 CLOSE PVCE		
12	86240600	41526	1	HOSEBARB, 3/4 MPTX1, HOSE 90DEG		
13	86233110	20018	2	CLAMP, 1.00" WORM GEAR		
14	86009700	82267	1	PLUG, 5/8" DRAIN HOSE		
15	86270510	51457	1	LANYARD, .093 X 6 NYLON		WAS 78499
16	86001600	40076	1	SLEEVE, .63 ID X 1.0 OD		
17	86007940	73836	1	STRAINER, DEEP, 100 MESH		
-	86005870	59021	-	O-RING, FILTER SEAL RON-VIK		SERVICE ONLY
-	86136800	73839	-	SCREEN, 100 MESH STRAINER DEEP		SERVICE ONLY
18	86281950	39541	1	HOSE, 1/2ID WIRE BOUND X 32"		
19	86004310	39505	1	HOSE, 1.0 X 18.0 DRAIN		
20	86264920	27049	3	CABLE, TIE. 7" UL/CSA		
21	86274410	70195	4	SCR, 10-32 X 1.25 PPHMS SS		
22	86070690	140724	1	BRKT, SOLUTION PUMP		
23	86010650	87018	4	WASHER, #10 X 9/16 OD		
24	86006100	65176	1	PUMP ASM, 36V		
25	86271820	57270	1	NUT, 5/16-18 CAPTIVE "J" PLTD		
26	86279130	87083	1	WASHER, 5/16 SPLIT LOCK PLTD		
27	86276780	70728	1	SCR, 5/16-18 X 3/4 HHCS SS		
28	86197940	40027	2	HOSEBARB, 3/8MPTX1/2 90D DL		
29	86246090	51461	1	LANYARD, .093 X 6", LOOP - .26 EYE	*(11)	
30	86254320	730400	1	SPACER, .17 ID X .25 OD X 3/16 LG	*(11)	
31	86259450	87507	1	WASHER, 1.0 D X .1 THK, SEAL	*(11)	
32	86252730	70887	1	SCR, 8-32 X 1/2 BHCS SST	*(11)	
33	86248010	57312	1	NUT, 8/32 ACORN CAP, PLATED	*(11)	
34	86226950	40109	1	1" HOSE BARB X 3/4" GHT NYLON	*(11)	
35	86073960	22104	1	CAP, 3/4" GHT W/.17 HOLE	*(11)	
36	86235450	31068	1	ELBOW, 3/8 FPT PVC SCH 80	*(25)	
37	86001590	40049	1	HOSEBARB, 3/8 MPT X 1/2 NYLON	*(25)	
38	86197420	31026	1	ELBOW, 3/8 NPT STREET	*(25)	
39	86225680	84201	1	VALVE, 3/8" FPT BALL	*(25)	
40	86197540	40013	1	HOSEBARB, 3/8 MPT X 1/2 DL	*(25)	

*SEE SERIAL NUMBER PAGE.

SQUEEGEE - DISK

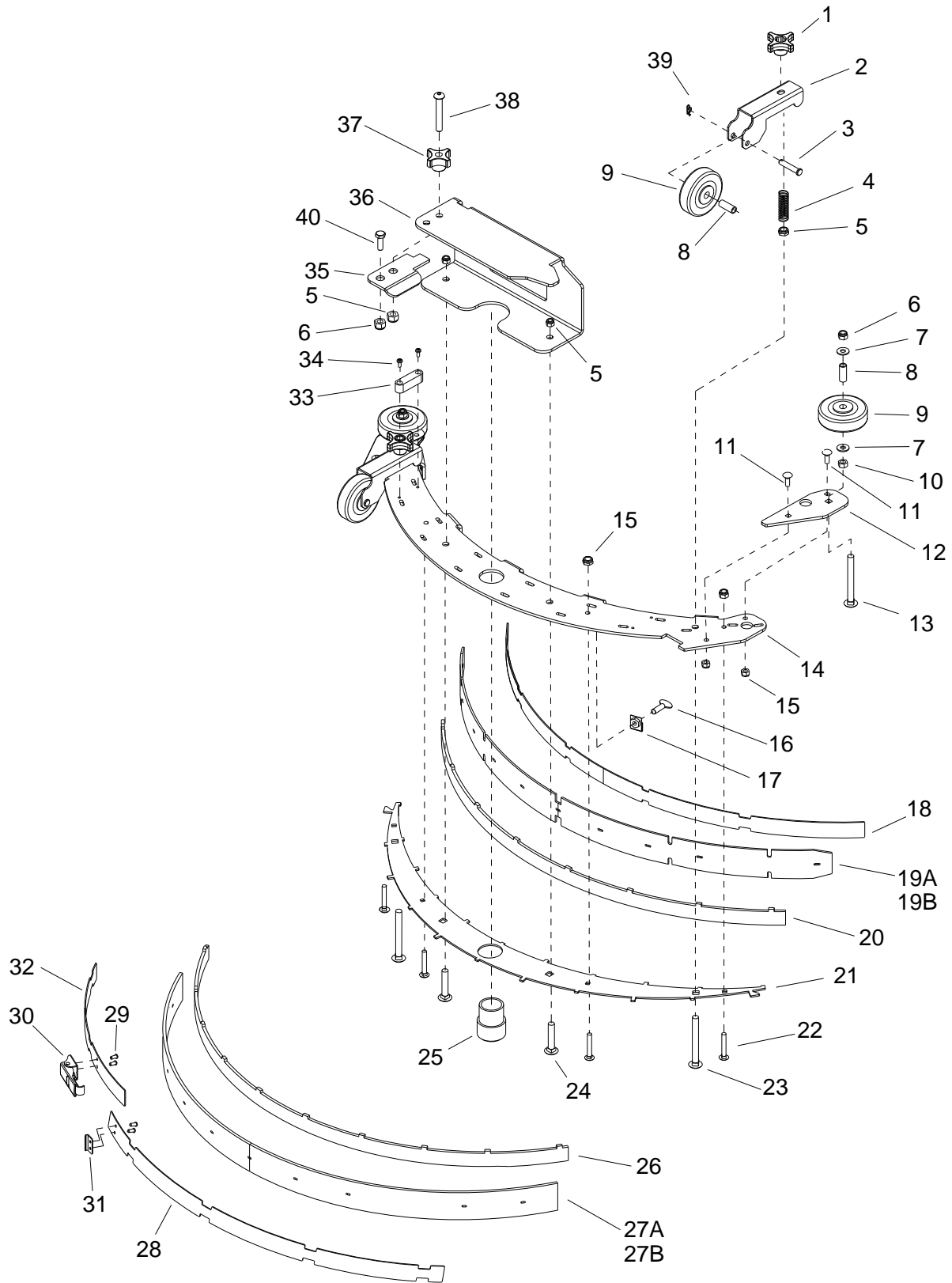

SQUEEGEE - DISK

REF	PART NO.	PRV NO.	QTY	DESCRIPTION	SERIAL NO. FROM	NOTES:
1	86004890	48095	2	KNOB, ALUM 3/8-16 NYLOCK NUT SS		
2	86070920	140759	2	BRKT, SQG WHEEL		
3	86006270	66276	2	PIN, CLEVIS 5/16 X 1.63 PLTD		
4	86007780	73576	2	SPRING, COMP .60D X 2.0L X .045 W		
5	86005630	57022	2	NUT, 3/8-16 HEX NYLOCK THIN SS		
6	86270830	57023	3	NUT, 5/16-18 HEX NYLOCK SS		
7	86010670	87029	4	WASHER, 5/16 FLAT SS		
8	86001350	140390	2	BUSHING, SPANNER .435 X 1.10		
9	86011020	89202	4	WHEEL, 3" DIA CUSHION RUBBER		
10	86005650	57031	2	NUT, 5/16-18 HEX		
11	86276950	70772	4	SCR, 1/4-20 X 3/4 CARRIAGE SS		
12	86083290	66463	2	PLATE, SQG WHEEL NMT BUMPER		
13	86276710	70717	2	SCR, 5/16-18 X 2.0 CARRIAGE SS		
14	86083250	66459	1	PLATE, SQG TOP 33"		
15	86271870	57290	4	NUT, 1/4-20 HEX NYLOCK THIN SS		
16	86007040	70680	5	SCR, 5/16-18 X 1 THUMB SS TYPE P		
17	86271820	57270	5	NUT, 5/16-18 CAPTIVE "J" PLTD		
18	86087830	140760	1	STRAP, SQUEEGEE		
19A	86001630	140764	1	BLADE, SQU, FRONT 36.7		
19B	86283540	140938	1	BLADE, SQU, FRONT 36.7 URETHANE		
20	86083270	66461	1	PLATE, SQG VERTICAL FILLER (F)		
21	86083260	66460	1	PLATE, SQG BOTTOM 33"		
22	86277000	70777	4	SCR, 1/4-20 X 1.5 CARRIAGE SS		
23	86276990	70776	2	SCR, 3/8-16 X 3.5 CARRIAGE SS		
24	86277450	70846	2	SCR, 3/8-16 X 2 LG CARRIAGE SS		
25	86008390	78493	1	TUBE ASM, SQUEEGEE VAC		
26	86083280	66462	1	PLATE, SQG VERTICAL FILLER		
27A	86001580	140763	1	BLADE, SQU, REAR 40.6 LINATEX		
27B	86283510	140935	1	BLADE, SQU, REAR 40.6 URETHANE		
28	86066440	140761	1	BAND, REAR SQUEEGEE		
29	86006400	67380	4	RIVET, 5/32 OF X 1/8 GRIP		
30	86009170	81488	1	LATCH, SQUEEGEE STRAP		
31	86009180	81489	1	STRIKER, SQUEEGEE STRAP REAR		
32	86066450	140762	1	BAND, SQG REAR RH		
33	86009910	82576	1	VIAL, LEVEL		
34	86274130	70098	2	SCR, 8-32 X 3/8 PHTC 'F' PLATD		
35	86071070	140795	1	BRKT, SQG QUICK CONNECT LOCK		
36	86071060	140794	1	BRKT, SQG QUICK CONNECT MTG		
37	86009200	81535	1	KNOB, 3/8-16 4 PRONG ALUM		
38	86277440	70845	1	SCR, 3/8-15 X 2.5 LG BSHCS SS		
39	86008660	80605	2	COTTER, 5/16 RING		
40	86277460	70847	1	SCR, 5/16-18 X 5/8 BSHCS SS		

NOTE: Complete Squeegee Assembly available, Part No. 47455

SQUEEGEE - CYLINDRICAL

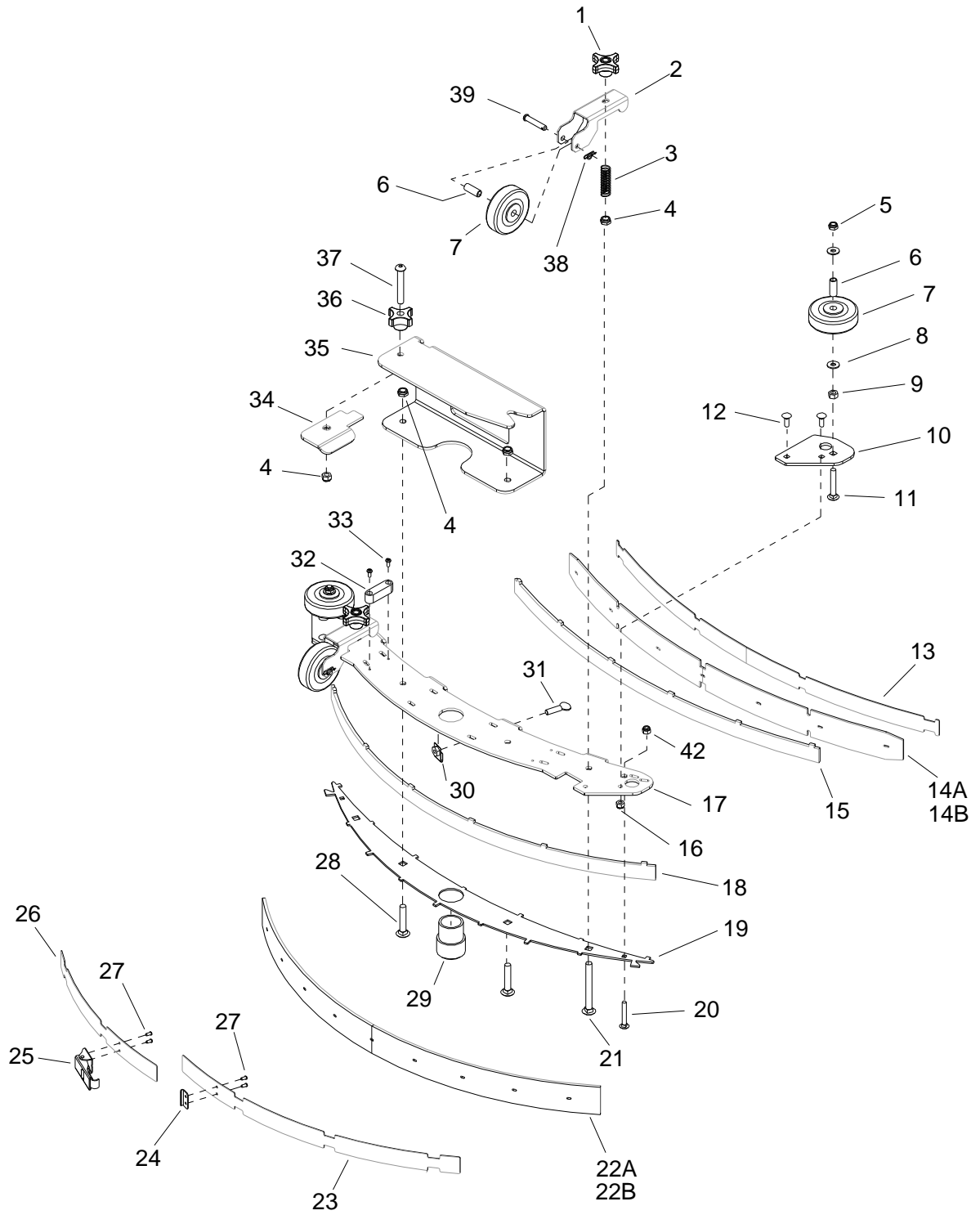

SQUEEGEE - CYLINDRICAL

REF	PART NO.	PRV NO.	QTY	DESCRIPTION	SERIAL NO. FROM	NOTES:
1	86004890	48095	2	KNOB, ALUM 3/8-16 NYLOCK NUT SS		
2	86069870	140531	2	BRKT, SQG WHEEL		
3	86007780	73576	2	SPRING, COMP .60 D X 2.0 L X .045 W		
4	86005630	57022	6	NUT, 3/8-16 HEX NYLOCK THIN SS		
5	86271840	57285	2	NUT, 5/16-18 HEX NYLOCK THIN SS		
6	86001350	140390	2	BUSHING, SPANNER .435 X 1.10		
7	86011020	89202	4	WHEEL, 3" DIA CUSHION RUBBER		
8	86010670	87029	2	WASHER, 5/16 FLAT SS		
9	86005650	57031	2	NUT, 5/16-18 HEX		
10	86083420	66822	2	PLATE, BUMPER WHEEL MOUNT		
11	86276710	70717	2	SCR, 5/16-18 X 2.0 CARRIAGE SS		
12	86276950	70772	4	SCR, 1/4-20 x 3/4 CARRIAGE SS		
13	86087850	140833	1	STRAP, SQUEEGEE		
14A	86283490	140841	1	BLADE, SQU FRONT 29.4		
14B	86283530	140937	1	BLADE, SQU FRONT 29.4 URETHANE		
15	86083470	66828	1	PLATE, SQG VERTICAL FILLER (F)		
16	86005810	57245	4	NUT, 1/4-20 HEX NYLOCK SS		
17	86071260	140830	1	BRKT, SQUEEGEE TOP PLATE		
18	86083460	66827	1	PLATE, SQG VERTICAL FILLER (R)		
19	86083430	66823	1	PLATE, SQUEEGEE BOTTOM 33 IN		
20	86277000	70777	2	SCR, 1/4-20 X 1.5 CARRIAGE SS		
21	86276990	70776	2	SCR, 3/8-16 X 3.5 CARRIAGE SS		
22A	86283500	140842	1	BLADE, SQU REAR 31.3 LINATEX		
22B	86283520	140936	1	BLADE, SQU REAR 31.3 URETHANE		
23	86066490	140834	1	BAND, REAR SQUEEGEE		
24	86009180	81489	1	STRIKER, SQUEEGEE STRAP REAR		
25	86009170	81488	1	LATCH, SQUEEGEE STRAP		
26	86066500	140835	1	BAND, REAR SQUEEGEE		
27	86006400	67380	4	RIVET, 5/32 OF X 1/8 GRIP		
28	86277450	70846	2	SCR, 3/8-16 X 3 LG CARRIAGE SS		
29	86008390	78493	1	TUBE ASM, SQUEEGEE VAC		
30	86271820	57270	4	NUT, 5/16-18 CAPTIVE "J" PLTD		
31	86007040	70680	4	SCR, 5/16-1/ X 1 THUMB SS TYPE P		
32	86009910	82576	1	VIAL, LEVEL		
33	86274130	70098	2	SCR, 8-320X 3/8 PHTC "F" PLTD		
34	86071070	140795	1	BRKT, SQG QUICK CONNECT LOCK		
35	86071190	140823	1	BRKT, SQG QUICK CONNECT MTG		
36	86009200	81535	1	KNOB, 3/8-16 4 PRONG ALUM		
37	86277440	70845	1	SCR, 3/8-16 X 2.50 LG BSHCS SS		
38	86008660	80605	2	COTTER, 5/16" RING		
39	86006270	66276	2	PIN, CLEVIS 5/16 X 1.63 PLTD		
40	86277460	70847	1	SCR, 5/16-18 x 5/8 BSHCS SS	*(5)	
41	86270830	57023	1	NUT, 5/16-18 HEX NYLOCK SS	*(5)	
42	86271870	57290	2	NUT, 1/4-20 HEX NYLOCK THIN SS		

*SEE SERIAL NUMBER PAGE.

SQUEEGEE LIFT-BASIC

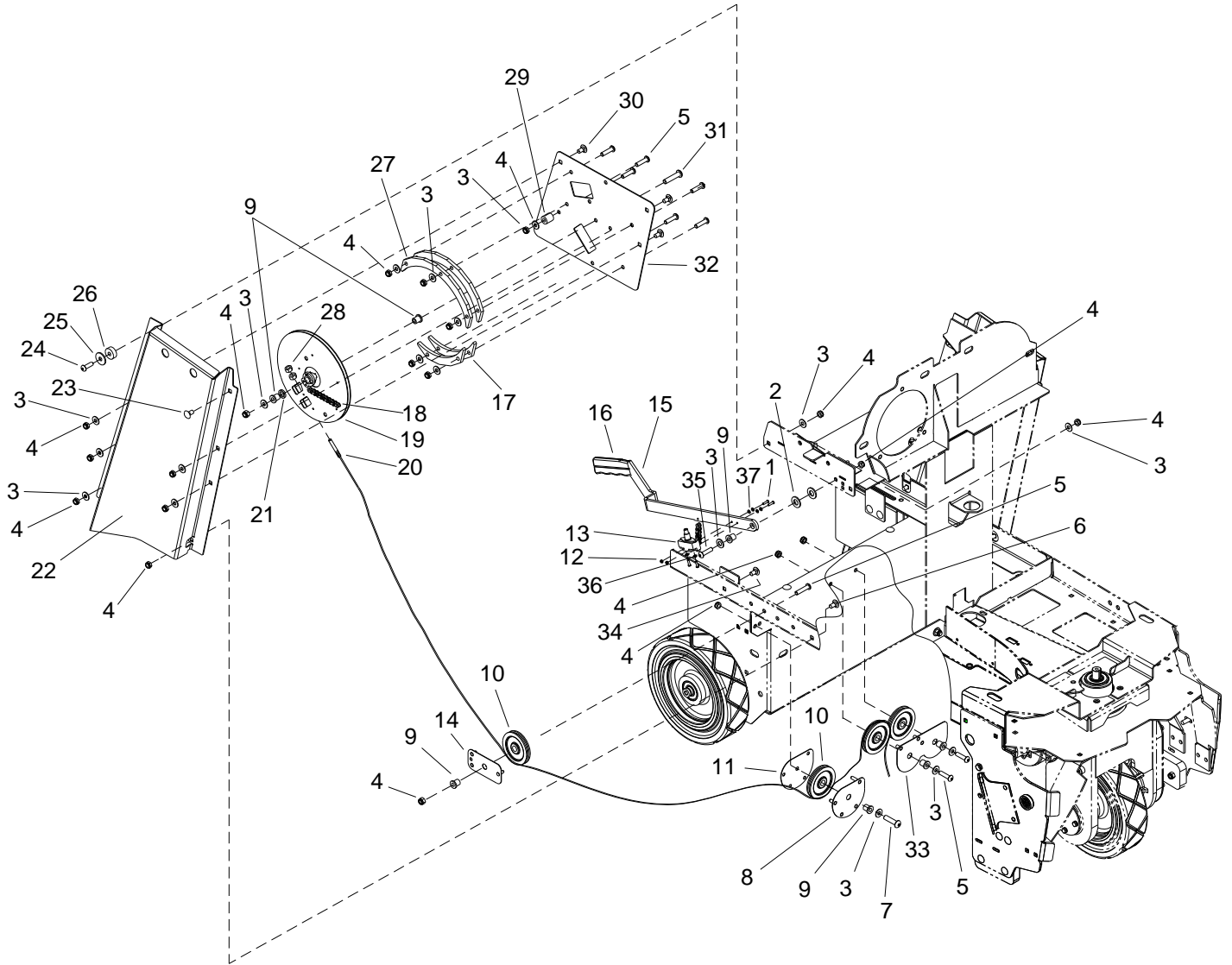

SQUEEGEE LIFT-BASIC

REF	PART NO.	PRV NO.	QTY	DESCRIPTION	SERIAL NO. FROM	NOTES:
1	86277490	70851	2	SCR, 6-32 X 1.5 PPHMS SS		
2	86259420	87232	2	WASHER, THRUST .51ID X 1 OD		
3	86010670	87029	19	WASHER, 5/16 FLAT SS		
4	86270830	57023	21	NUT, 5/16-18 HEX NYLOCK SS		
5	86276760	70724	9	SCR, 5/16-18 X 1.25 BSHCS SS		
6	86277460	70847	1	SCR, 5/16-18 X 5/8 BSHCS SS		
7	86274720	70264	1	SCR, 5/16-18 X 1.5 HHCS SS		
8	86083490	66831	1	PLATE, PULLEY MOUNT, CORNER	*(4)	
9	86231150	09151	7	BUSHING FLANGED, .314ID X .502OD		
10	86223370	66464	4	PULLEY, PLASTIC 3.0 DIA.		
11	86083500	66832	1	PLATE, PULLEY RETAINER, CORNER	*(4)	
12	86270920	57049	2	NUT, 6-32 HEX NYLOCK SS		
13	86257120	72192	1	SWITCH, DPST SNAP ACTION		
14	86073600	66833	1	BRKT, PULLEY RETAINER, SINGLE	*(4)	
15	86076610	38319	1	HANDLE, SQUEEGEE LIFT		
16	86238360	36215	1	GRIP, 3/16 X 1.0 ORANGE		
17	86083360	66474	2	PLATE, KEEPER BOTTOM		
18	86232670	270099	1	CHAIN, #35, 3/8 PITCH X 29		
19	86073890	270096	1	CAM, SQUEEGEE LIFT		
20	86231560	270097	1	CABLE, SQUEEGEE LIFT BASIC		
21	86279350	87140	1	WASHER, WAVE 1/2ID X 3/4 X .125		
22	86091820	140807	1	BRKT, SIDE CHANNEL R		
23	86276070	70593	1	SCR, 5/16-18 X 3/4 CARRIAGE SS		
24	86066130	89501	1	ASM, HANDLE RETAINER	*(15)	
25	86295860	-	1	INSULATOR, SWITCH		
26	86254280	730331	1	SPACER, 1.00 OD X .32 ID X .375		
27	86083350	66473	2	PLATE, KEEPER TOP		
28	86270870	57029	2	NUT, 1/4-20 HEX SS		
29	86254580	80835	1	SPACER, .32ID X .71OD X .76L NYL		
30	86277410	70840	4	SCR, 5/16-18 X 5/8 CARRIAGE SS		
31	86277400	70839	1	SCR, 5/16-18 X 1.75 BSHCS SS		
32	86083340	66471	1	PLATE, CAM MOUNT		
33	86083440	66824	1	PLATE, PULLEY MOUNTING, CENTER		
34	86276070	70593	1	SCR, 5/16-18 X 3/4 CARRIAGE SS		
35	86007020	70673	1	SCR, 5/16-18 X 1.25 HHCS SS NP		
36	86278980	87014	2	WASHER, #8 INT.STAR		
37	86279450	87161	4	WASHER, #6 FLAT SAE PLTD		

*SEE SERIAL NUMBER PAGE.

SQUEEGEE LIFT-DELUXE

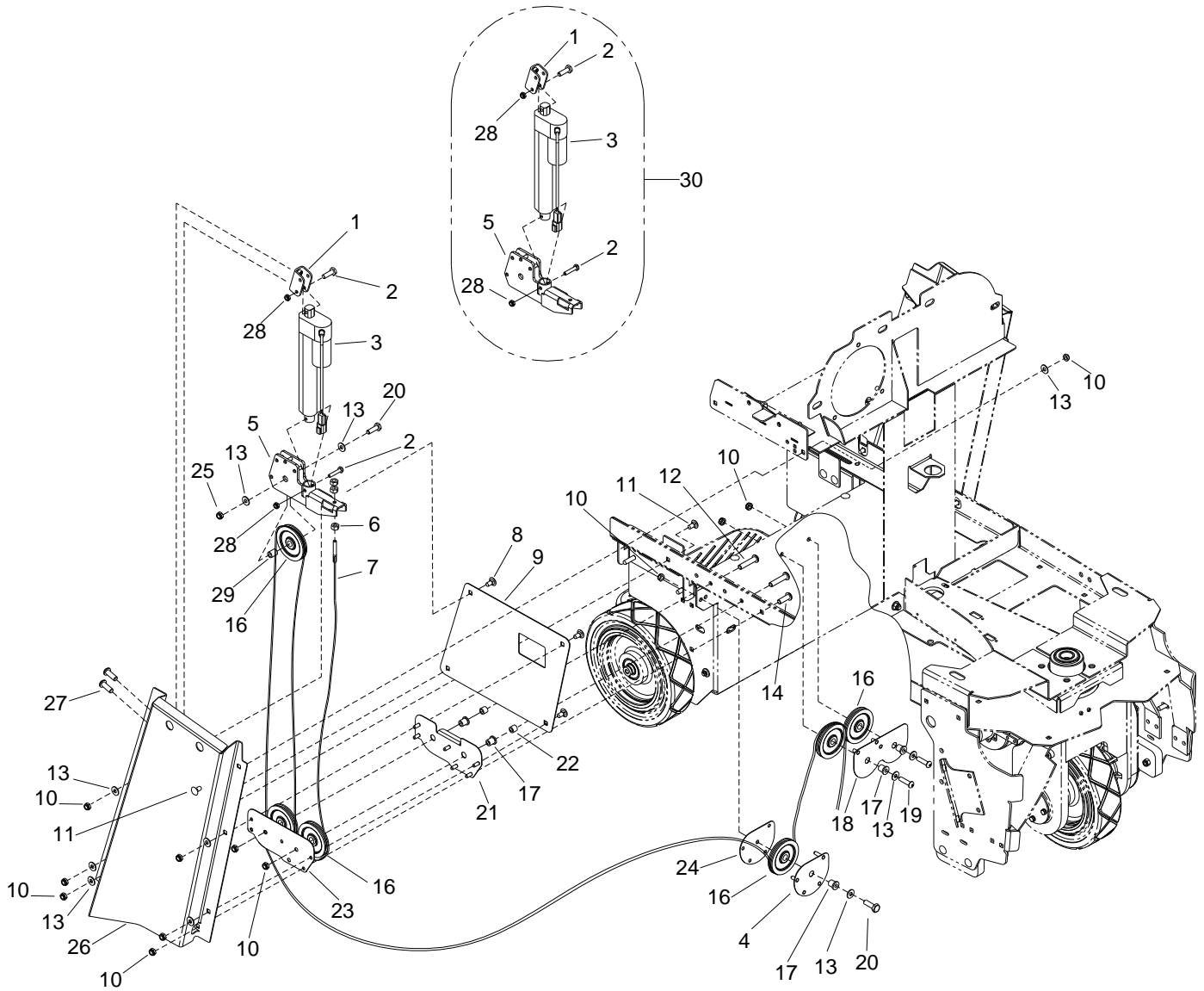

SQUEEGEE LIFT-DELUXE

REF	PART NO.	PRV NO.	QTY	DESCRIPTION	SERIAL NO. FROM	NOTES:
1	86068190	140793	1	BRACKET, ACTUATOR MOUNT		
2	86273820	70019	1	SCR, 1/4-20 X 1.25 HHCS		
3	86316550	-	1	ACTUATOR, 36VDC, 4.5" STROKE	*(32)	WAS 05254***
4	86083490	66831	1	PLATE, PULLEY MOUNT, CORNER	*(4)	
5	86068230	140840	1	BRACKET, SQG LIFT PULLEY MOUNT	*(4)	
6	86270870	57029	3	NUT, 1/4-28 HEX SS		
7	86002780	270098	1	CABLE, SQUEEGEE LIFT DELUXE		
8	86277410	70840	4	SCR, 5/16-18 X 5/8 CARRIAGE SS		
9	86075430	270700	1	COVER, SQUEEGEE LIFT		
10	86270830	57023	15	NUT, 5/16-18 HEX NYLOCK SS		
11	86276070	70593	3	SCR, 5/16-18 X 3/4 CARRIAGE SS		
12	86277400	70839	2	SCR, 5/16-8 X 1.75 BSHCS SS		
13	86010670	87029	10	WASHER, 5/16 FLAT SS		
14	86277460	70847	1	SCR, 5/16-18 X 5/8 BSHCS SS		
15	86259420	87232	1	WASHER, THRUST .51ID X 1 OD BRO		
16	86223370	66464	6	PULLEY, PLASTIC 3.0 DIA		
17	86231150	09151	5	BUSHING, FLANGE, .314ID X .502OD		
18	86083440	66824	1	PLATE, PULLEY MOUNTING, CENTER		
19	86276760	70724	2	SCR, 5/16-18 X 1.25 BSHCS SS		
20	86274720	70264	2	SCR, 5/16-18 X 1.50 HHCS SS		
21	86071300	140843	1	BRACKET, PULLEY RETAINER, DOUBLE	*(4)	
22	86224290	730008	2	SPACER, .317ID X .50D X .44 LG		
23	86071310	140844	1	BRKT, PULLEY RETAINER, DOUBLE	*(4)	
24	86083500	66832	1	PLATE, PULLEY RETAINER, CORNER	*(4)	
25	86271840	57285	1	NUT, 5/16-18 HEX NYLOCK THIN SS		
26	86074160	270101	1	CHANNEL, RIGHT DELUXE		
27	86277480	70850	2	SCR, 5/16-18 X 1/2 PTHMS SS		
28	86271870	57290	2	NUT, 1/4-20 HEX NYLOCK THIN SS		
29	86228880	09132	1	BEARING, .314 ID X .503 OD X 1		
30	86326650	-	-	ASM, ACTUATOR AND BRACKETS		***

*SEE SERIAL NUMBER PAGE.

**CALL MANUFACTURER FOR SERIAL NUMBER

*** FOR REPLACEMENT OF 05254

SQUEEGEE SWING

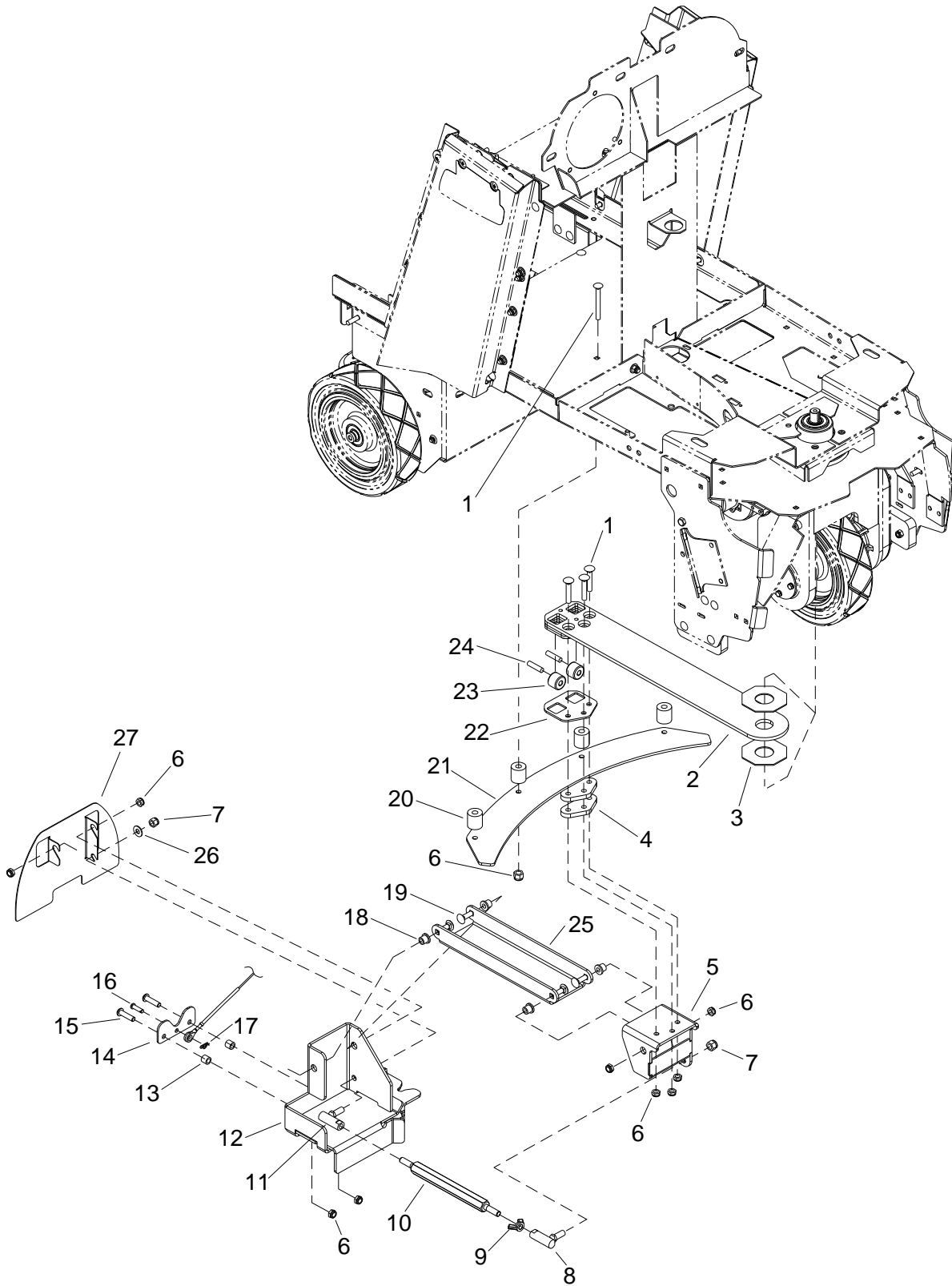

SQUEEGEE SWING

REF	PART NO.	PRV NO.	QTY	DESCRIPTION	SERIAL NO. FROM	NOTES:
1	86276690	70715	7	SCR, 5/16-18 X 1.75 CARR SS		
2	86091530	140787	1	BRACKET, SQUEEGEE SIDE PIVOT		
3	86090300	87247	2	WASHER, 1.25 ID X .075 OCTAGON		
4	86083370	66475	2	PLATE, SQG SWING SPACER		
5	86091540	140800	1	BRACKET, H PIVOT MOUNT		
6	86270830	57023	9	NUT, 5/16-18 HEX NYLOCK SS		
7	86271530	57216	2	NUT, 3/8-24 HEX NYLOCK		
8	86008810	80697	1	BALL JOINT ASY, 3/8-24 RH		
9	86271980	57303	1	NUT, 3/8-24 WING SS		
10	86223590	67510	1	ROD, CAMBER ADJUST		
11	86001320	140353	1	BALL JOINT ASSY, 3/8-24 LH		
12	86091810	140798	1	BRKT, SQG QUICK CONNECT		
13	86224290	730008	2	SPACER, .317ID X .500 X .44LG		
14	86083400	66479	1	PLATE, CABLE RETAINING		
15	86276760	70724	2	SCR, 5/16-18 X 1.25 BSHCS SS		
16	86272630	80771	1	PIN, CLEVIS 1/4 X .88 PLTD		
17	86008650	80604	1	COTTER, 1/4 RING		
18	86228840	09124	4	BEARING, FLANGED .314 ID X .502 OD		
19	86277030	70780	4	SCR, 5/16-18 X 1.25 CARRIAGE SS		
20	86224380	730336	4	SPACER, 1 OD X .343 ID X 1.063		
21	86083150	66446	2	PLATE, SQUEEGEE SWING		
22	86083310	66468	1	PLATE, WHEEL RETAINER		
23	86226030	89268	2	WHEEL, 1.000 OD X .323 ID X .750 SS		
24	86222580	66466	2	PIN, .312 DIA X 1.250 LG SS		
25	86070820	140740	2	BRKT, SQUEEGEE SWING HORIZ		
26	86278910	-	1	WASHER, 3/8 ID X 7/8 OD SS	*(33)	
27	86326670	-	1	PLATE, CABLE GUARD	*(33)	

*SEE SERIAL NUMBER PAGE

SQUEEGEE LIFT - CYLINDRICAL

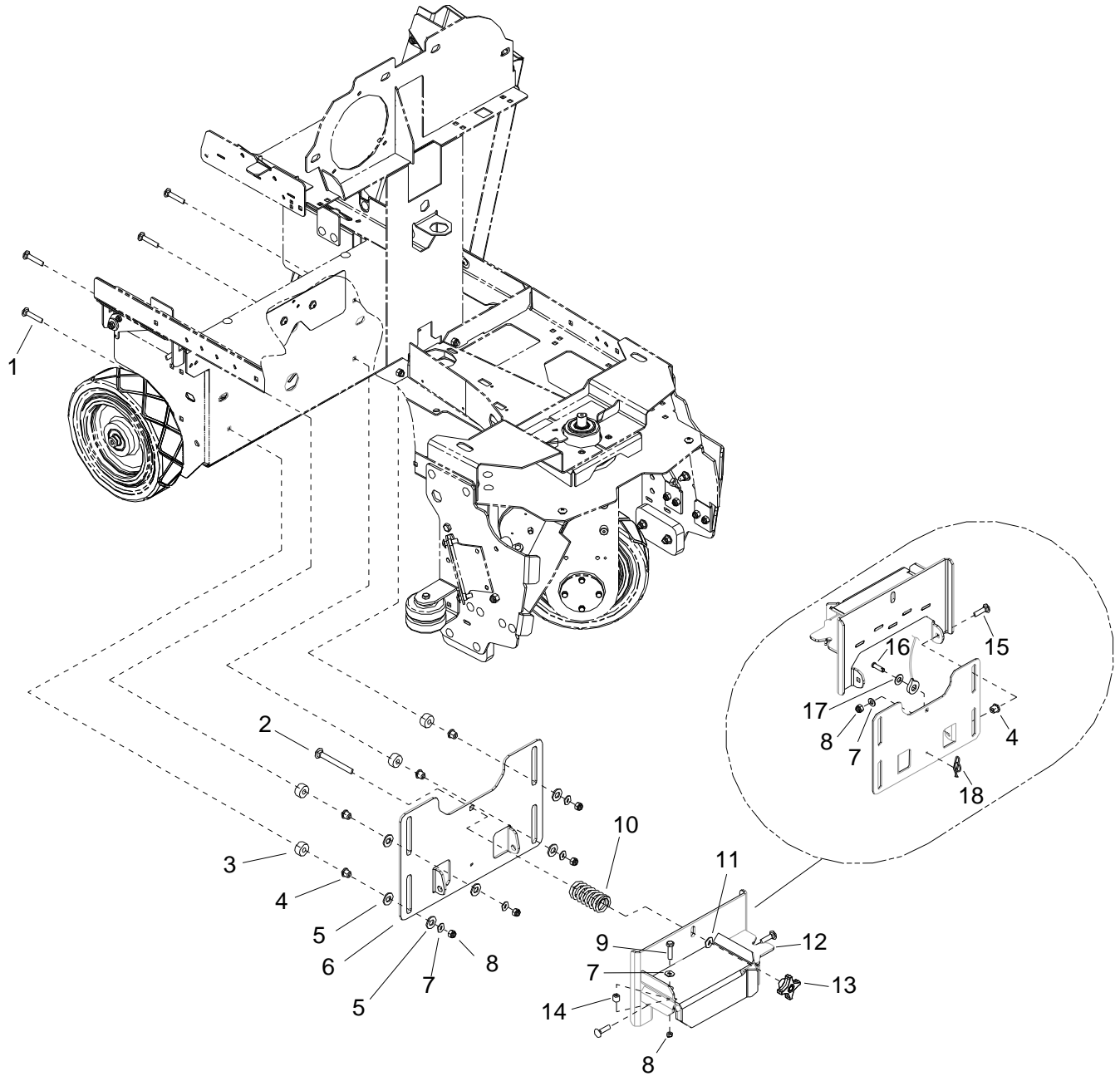

SQUEEGEE LIFT - CYLINDRICAL

REF	PART NO.	PRV NO.	QTY	DESCRIPTION	SERIAL NO. FROM	NOTES:
1	86276690	70715	4	SCR, 5/16-18 X 1.75 CARR SS		
2	86276990	70776	1	SCR, 3/8-16 X 3.5 CARRIAGE SS		
3	86224370	730335	4	SPACER, 1 OD X .391 ID X .500		
4	86228840	09124	6	BEARING, FLANGED .314 ID X .502 OD		
5	86259420	87232	8	WASHER, THRUST .51 ID X 1 OD BRO		
6	86071160	140819	1	BRKT, SQG MOUNT VERTICAL		
7	86010670	87029	7	WASHER, 5/16 FLAT SS		
8	86270830	57023	7	NUT, 5/16-18 HEX NYLOCK SS		
9	86007020	70673	1	SCR, 5/16-18 X 1.25 HHCS SS NP		
10	86007270	730006	1	SPRING, COMP 1.10 OD X 2.0 L X .148 W		
11	86278910	87003	1	WASHER, 3/8 ID X 7/8 OD SS		
12	86094270	730344	1	SQG TRACK WHEEL		
13	86004890	48095	1	KNOB, ALUM 3/8-16 NYLOCK NUT SS		
14	86224290	730008	1	SPACER, .317 ID X .50 D X .44 LG		
15	86277030	70780	2	SCR, 5/16-18 X 1.25 CARRIAGE SS		
16	86009560	82053	1	PIN, CLEVIS 1/4 X .63 PLTD		
17	86010630	87013	1	WASHER, 1/4 ID X 5/8 OD SS		
18	86008650	80604	1	COTTER, 1/4" RING		

SQUEEGEE LIFT - CYLINDRICAL

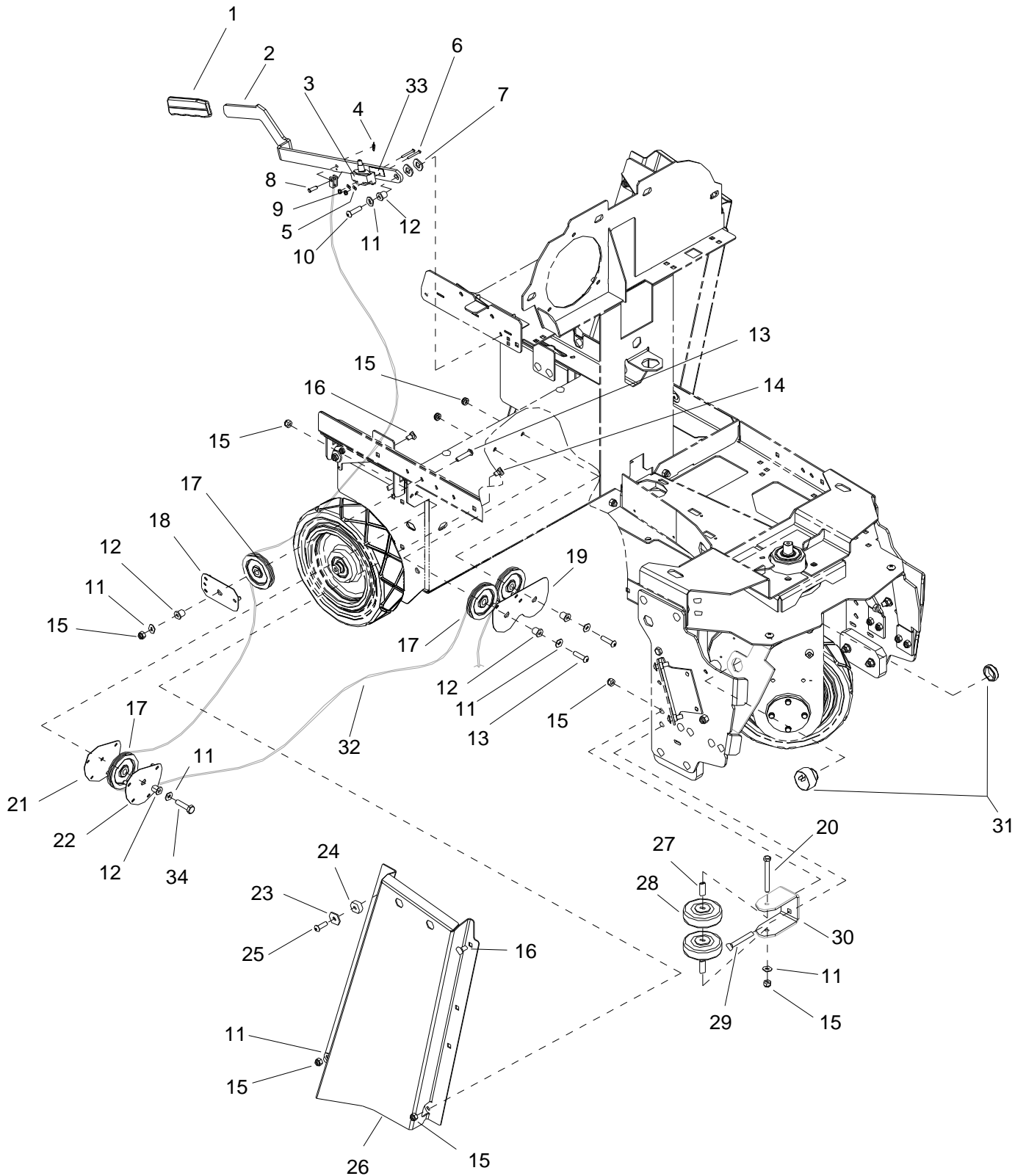

SQUEEGEE LIFT - CYLINDRICAL

REF	PART NO.	PRV NO.	QTY	DESCRIPTION	SERIAL NO. FROM	NOTES:
1	86238360	36215	1	GRIP, 3/16 X 1.0 ORANGE		
2	86076610	38319	1	HANDLE, SQUEEGEE LIFT		
3	86257120	72192	1	SWITCH, DPST SNAP ACTION		
4	86008650	80604	1	COTTER, 1/4" RING		
5	86279450	87161	2	WASHER, #6 FLAT SAE PLTD		
6	86275550	70500	2	SCR, #6-32 X 1.25 PPHMS		
7	86259420	87232	2	WASHER, THRUST .51 ID X 1 OD BRO		
8	86009560	82053	1	PIN, CLEVIS 1/4 X .63 PLTD		
9	86270920	57049	2	NUT, 6-32 HEX NYLOCK SS		
10	86007020	70673	1	SCR, 5/16-18 X 1.25 HHCS SS NP		
11	86010670	87029	8	WASHER, 5/16 FLAT SS		
12	86231150	09151	5	BUSHING, FLANGE, .314 ID X .502 OD		
13	86276760	70724	3	SCR, 5/16-18 X 1.25 BSHCS SS		
14	86277460	70847	1	SCR, 5/16-18 X 5/8 BSHCS SS		
15	86270830	57023	12	NUT, 5/16-18 HEX NYLOCK SS		
16	86276070	70593	2	SCR, 5/16-18 X 3/4 CARRIAGE SS		
17	86223370	66464	4	PULLEY, PLASTIC 3.0 DIA		
18	86073600	66833	1	BRKT, PULLEY RETAINER, SINGLE		
19	86083440	66824	1	PLATE, PULLEY MOUNTING, CENTER		
20	86276910	70754	2	SCR, 5/16-18 X 3 HHCS SS NP		
21	86083500	66832	1	PLATE, PULLEY RETAINER, CORNER		
22	86083490	66831	1	PLATE, PULLEY MOUNT, CORNER		
23	86279630	87212	1	WASHER, .344 ID X .13 OD X .09 T PLTD		
24	86254280	730331	1	SCR, 8-32 X 1/4 SPHMS BLK NYL		
25	86006930	70514	1	SCR, 5/16-18 X 1.00 BSHCS SS		
26	86091820	140807	1	BRKT, SIDE CHANNEL R		
27	86001350	140390	4	BUSHING, SPANNER .435 X 1.10		
28	86011020	89202	4	WHEEL, 3" DIA CUSHION RUBBER		
29	86277130	70795	4	SCR, 5/16-18 X 1.00 CARRIAGE SS		
30	86071290	140837	2	BRKT, SIDE WHEEL MOUNT		
31	86239720	41520	1	HORN, 108 DB MINIATURE PIEZO		
32	86231570	270105	1	CABLE, SQG LIFT, SCRUBPLUS		
33	86295860	-	1	INSULATOR, SWITCH	*(23)	
34	86274720	70264	1	SCR, 5/16-18 X 1.50 HHCS SS		

*SEE SERIAL NUMBER PAGE.

STEERING

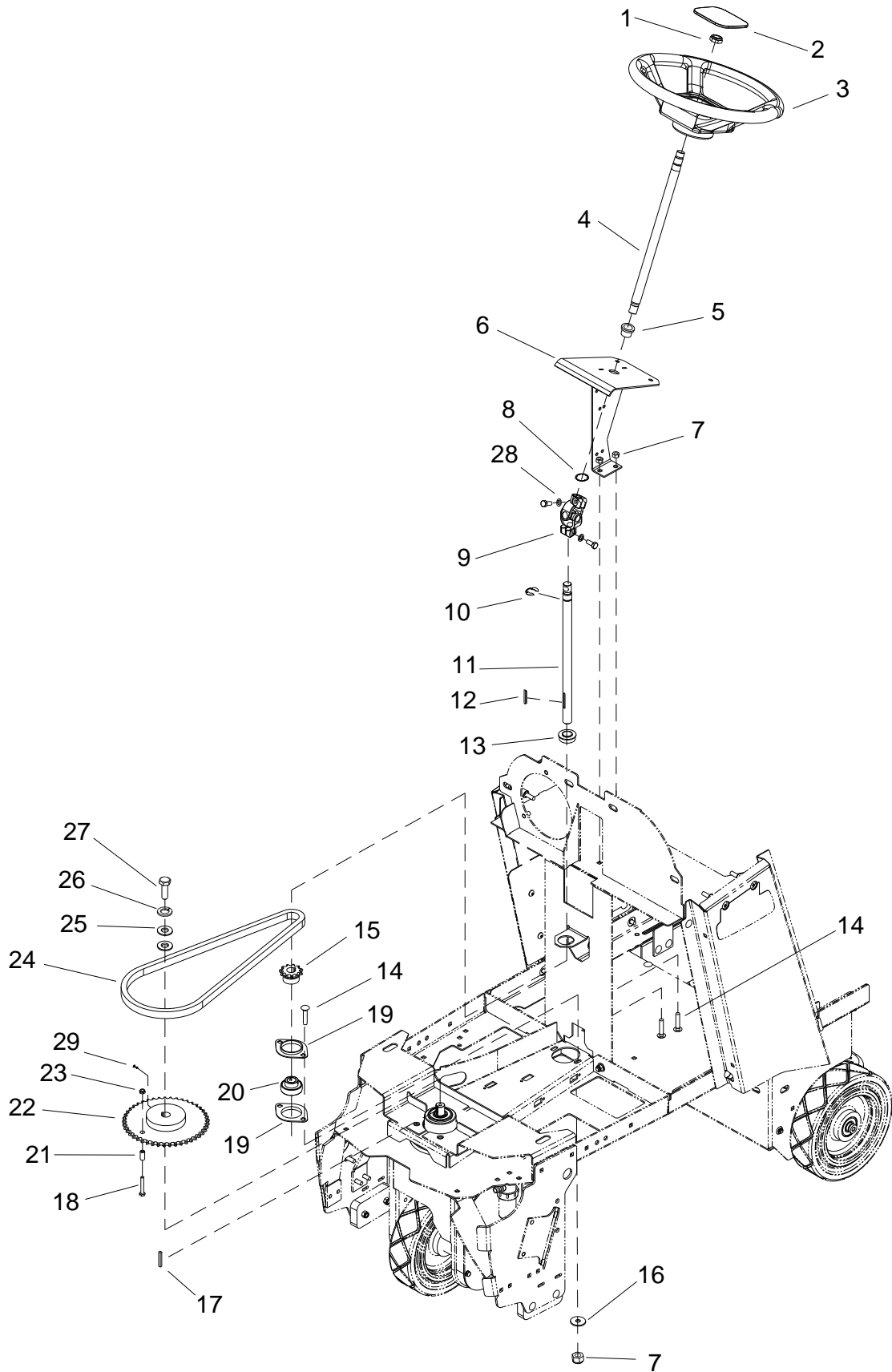

STEERING

REF	PART NO.	PRV NO.	QTY	DESCRIPTION	SERIAL NO. FROM	NOTES:
1	86271610	57228	1	NUT, 5/8-16 HEX NYLOCK THN		
2	86234810	27945	1	COVER, STEERING WHEEL		
3	86259610	730117	1	WHEEL, STEERING 40 SPLINE HUB		
4	86224050	730318	1	SHAFT, UPPER STEERING		
5	86228790	09111	1	BEARING, FLANGE .88ODX.75IDX.75		
6	86091740	140720	1	BRKT, UPPER STEERING		
7	86270830	57023	4	NUT, 5/16-18 HEX NYLOCK SS		
8	86005610	57016	1	NUT, 7/8 DIA PUSHLOCK		
9	86219600	45012	1	JOINT, UNIVERSAL FEMALE		
10	86272900	67416	1	RING, 3/4" KLIP		
11	86224060	730319	1	SHAFT, LOWER STEERING		
12	86219650	48110	1	KEY, 5MM SQ X 39MM L		
13	86228670	09072	1	BEARING, 3/4" BORE FLANGED		
14	86276070	70593	4	SCR, 5/16-18 X 3/4 CARRIAGE SS		
15	86224800	730315	1	SPROCKET, STEERING SHAFT		
16	86010670	87029	2	WASHER, 5/16 FLAT SS		
17	86135970	48045	1	KEY, 3/16 SQ X 5/8 LONG		
18	86275190	70377	1	SCR, 3/8-16 X 1.25 HHCS SS		
19	86008610	80595	2	FLANGE, BEARING PRESS STEEL		
20	86001030	09148	1	BEARING, BALL 3/4 BORE SPHERED		
21	86224320	730221	1	SPACER, .63 OD X .385ID X .64L		
22	86224810	730316	1	SPROCKET, DRIVE WHEEL STEERING		
23	86005630	57022	1	NUT, 3/8-16 HEX NYLOCK THIN SS		
24	86002750	270088	1	CHAIN, ISO 08B, 12.7MM PITCH		
25	86278940	87008	2	WASHER, 1/4 ID X 1-1/4OD		
26	86010780	87162	1	WASHER, 1/4 SPLIT LOCK PLTD		
27	86274330	70175	1	SCR, M6 X 20HHMS PLTD		
28	86279130	87083	2	WASHER, 5/16 SPLIT LOCK		
29	86253200	70806	1	SET SCR, M6 X 25 NP		SERVICE ONLY
-	86232780	279001	-	CHAIN, MASTERLINK 12.7MM		SERVICE ONLY

TANK

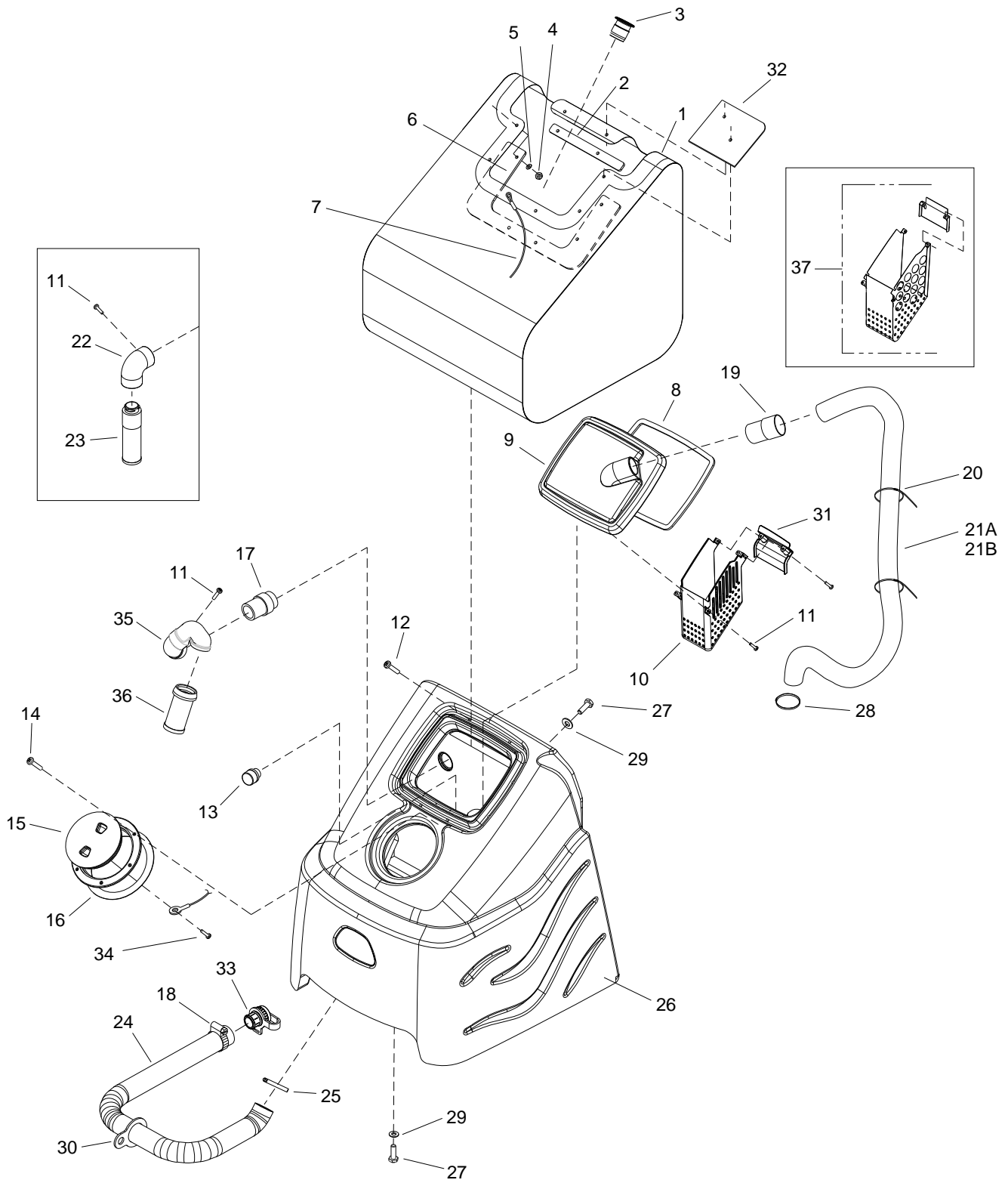

TANK

REF	PART NO.	PRV NO.	QTY	DESCRIPTION	SERIAL NO. FROM	NOTES:
1	86001510	140712	1	BAG, INNER TANK		
2	86006470	67513	1	RETAINER, BACK BAG	**	
3	86221900	54198	1	MANDREL, BAG		
4	86271940	57299	8	NUT, 1/4-20 ACORN SS		
5	86010630	87013	8	WASHER, 1/4-20 X 5/8 OD SS		
6	86006480	67514	1	RETAINER, MAIN BAG	**	
7	86246080	51368	1	LANYARD, 18.0 W/LOOP & EYE		
8	86004010	35274	1	GASKET, DOME EDGE		
9	86003350	28063	1	DOME, COVER, 10X13		
10	86310190	-	1	BASKET, STRAINER, DOME	*(31)	
11	86006860	70403	5	SCR, #10X1/2 PPHST TYPE B		
12	86276840	70744	8	SCR, 1/4-20X1 PFH BLK SS		
13	86256100	730333	1	STRAINER, 3/4-MNPT, 12 MESH		
14	86275800	70546	6	SCR, 8 X 3/4 PFHT/S BLK ZINC		
15	86002620	260-64A	1	ACCESS COVER CLEAR 6" W/RIM		
16	86004000	35255	1	GASKET, TANK LID		
17	86033570	78934	1	TUBE ASM		
18	86002390	20063	1	CLAMP, 1.75" WORM GEAR X .312		
19	86003010	27759	1	CUFF, HOSE 1.5" BLK A 2161		
20	86264950	27746	3	CABLE TIE, .19W X 11.5L BLK		
21A	86305960	-	1	HOSE ASM, 1.5 BLK PVC VAC X 67		DISK
21B	86004380	39550	1	HOSE ASM, 1.5 BLK VAC X 50		SCRUB PLUS
22	86197870	31101	1	ELBOW, 1.5 FS X FS 90 DEG		
23	86003680	34380	1	FLOAT, SHUT-OFF		
24	86311740	-	1	HOSE, 2.0 X 37.0, DRAIN	**	
-	86004430	39707	1	HOSE ASM, 2 X 37.0 DRAIN, ASM		HOSE & CAP
25	86002380	20046	1	CLAMP, 2.25" WORM GEAR		
26	86032870	75455	1	TANK		
27	86006760	70305	6	SCR, 5/16-18 x 3/4 HHCS GR5 PLTD		
28	86177050	03-000176	1	CLAMP, HOSE #20	*(14)	
29	86279630	87212	6	WASHER, .344 ID X 1.13 OD X .09T PLT		
30	86257570	51407	1	TETHER, DRAIN HOSE, 1.5		
31	86310180	-	1	PLATE, STRAINER BASKET	*(31)	
32	86003710	34447	1	FLAP, TANK DEBRIS	*(7)	
33	86004440	39717	1	CAP, DRAIN HOSE		
34	86277560	70866	1	SCR, #6 X 1/2 SHT MTL SS		
35	86025200	31377	1	ELBOW ASM, FLOAT	*(19)	
36	86199840	090-12A	1	FLOAT SCREEN CAGE ASSY	*(19)	
37	98406760	-	1	KIT, DOME BASKET		

* SEE SERIAL NUMBER PAGE.

** CALL MANUFACTURER FOR SERIAL NUMBER

VACUUM

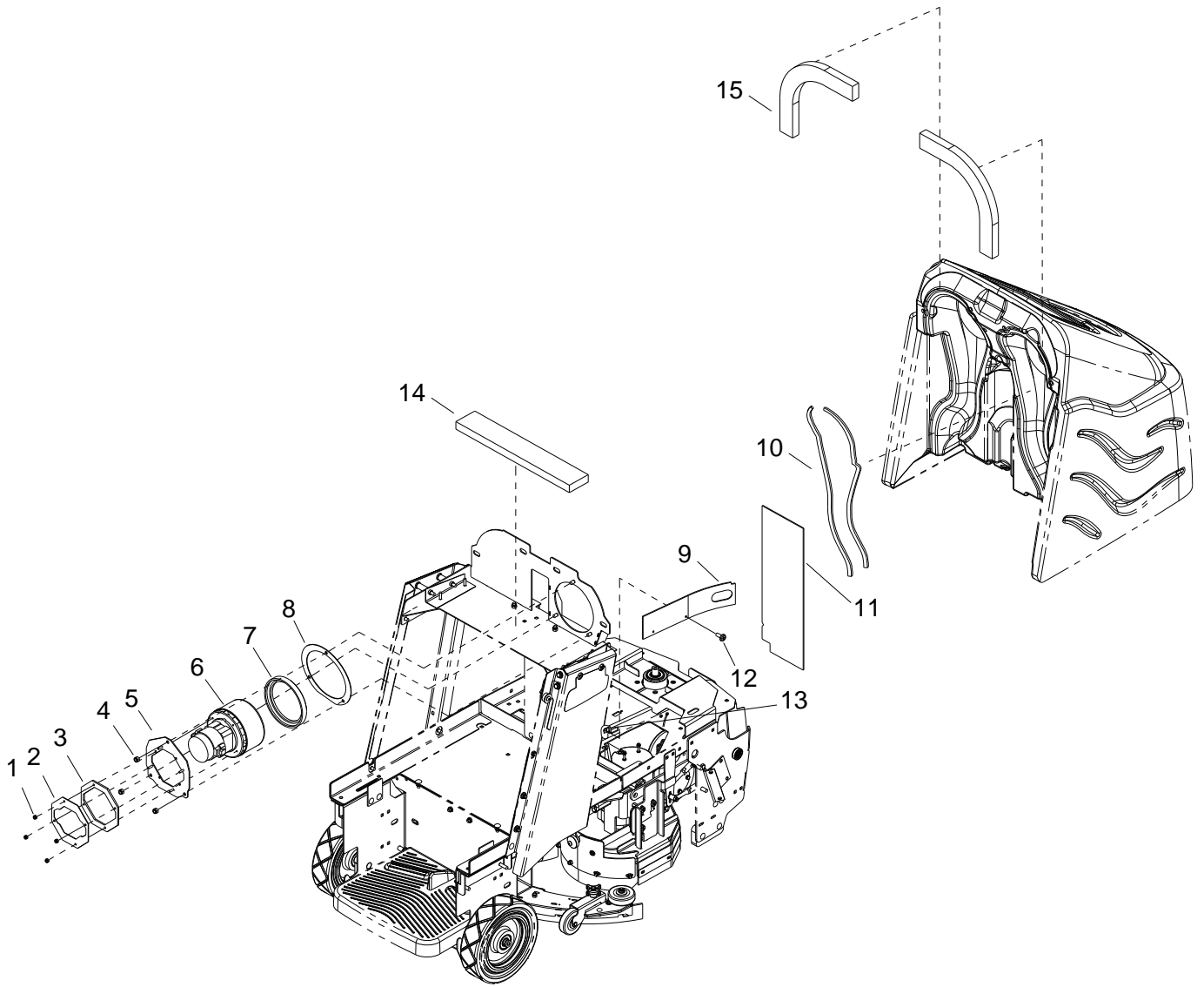

VACUUM

REF	PART NO.	PRV NO.	QTY	DESCRIPTION	SERIAL NO. FROM	NOTES:
1	86270990	57090	4	NUT, 10-32 HEX NYLOCK SS		
2	86083030	66430	1	PLATE, VAC MOTOR ADAPT		
3	86083010	66428	1	PLATE, VAC SPACER		
4	86270830	57023	3	NUT, 5/16-18 HEX NYLOCK SS		
5	86083020	66429	1	PLATE, VAC MOUNTING		
6	86005500	53809	1	VAC MOTOR 36VDC 3 STG		
-	86135310	140686	-	BRUSH SET, 24/36V VAC WINDSOR		SERVICE ONLY
7	86237880	35276	1	GASKET, 5.7 VAC MOTOR		
8	86237890	35277	1	GASKET, VAC MOUNT		
9	86078650	36241	1	GUARD, CHAIN RT		
10	86238040	36243	2	GASKET, 1/4 T X 3/4 W X 24 L		
11	86064740	270100	1	VAC CHANNEL COVER		
12	86274070	70086	2	SCR, 10-24 X 1/2 PPHMS		
13	86270860	57028	2	NUT, 10-24 U-TYPE SPEED		
14	86236530	34436	1	FOAM, POLYESTER, 1X3X18	*(3)	
15	86236540	34437	2	FOAM, POLY, 1X2 CURVED W/ADH	*(3)	

*SEE SERIAL NUMBER PAGE.

WHEEL-FRONT DRIVE, CHAIN

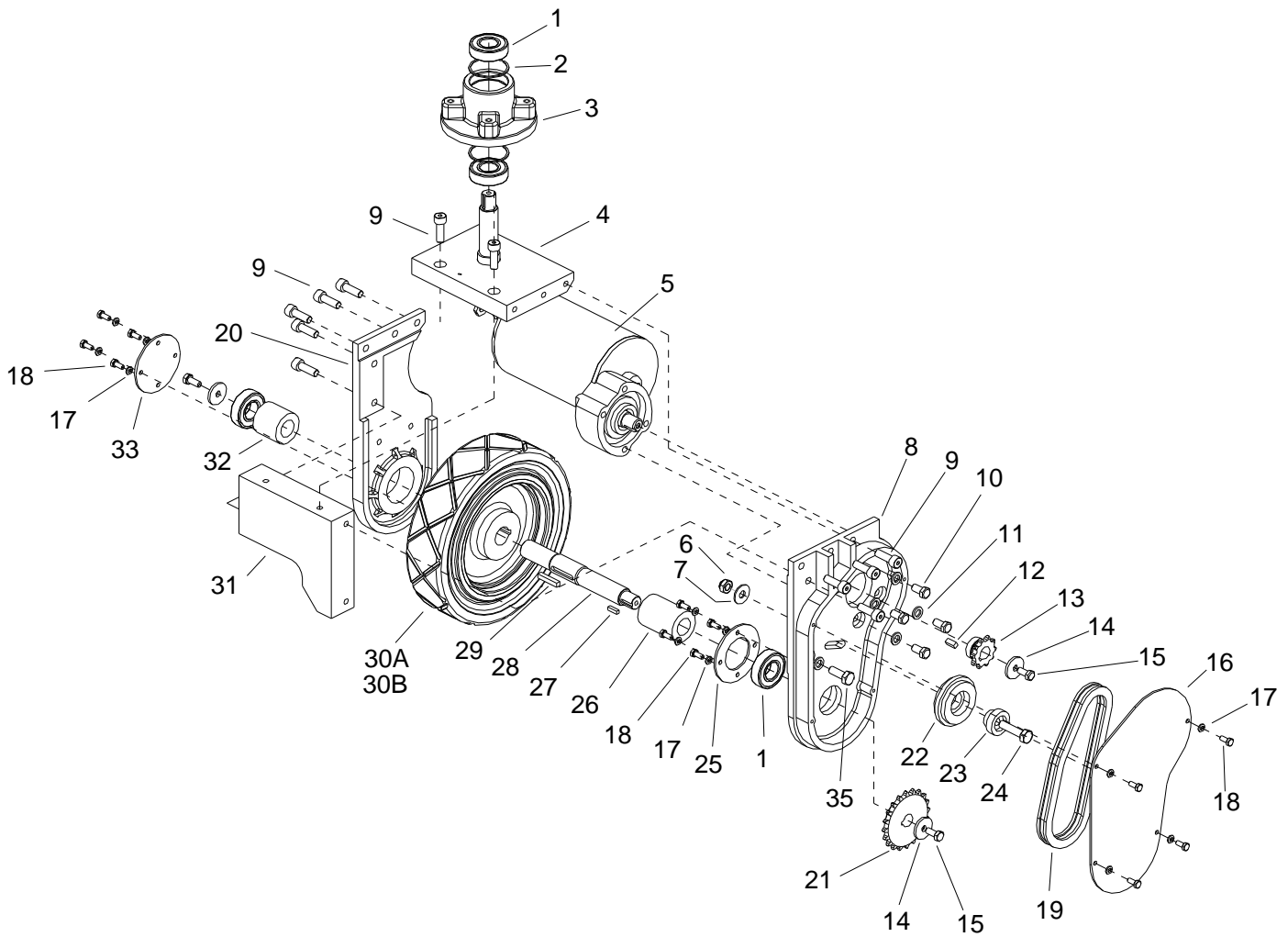

WHEEL-FRONT DRIVE, CHAIN

REF	PART NO.	PRV NO.	QTY	DESCRIPTION	SERIAL NO. FROM	NOTES:
1	86223980	09134	4	SEALED BALL BRNG, 25MM X 52MM		
2	86223480	67450	2	RING, 52MM INTERNAL SNAP		
3	86219420	41510	1	STEERING, HUB		
4	86224040	730306	1	SHAFT, ASM, DRIVE PIVOT		
5	86005510	53810	1	MOTOR, 36V 180RPM GEAR		
-	86216210	53820	-	BRUSH SET MOTOR 53810		
-	86227440	05261	-	ARMATURE 53810 MOTOR		
6	86136360	57275	1	NUT, M10X1.5 HEX NYLOCK PLTD		
7	86010720	87086	1	WASHER, M10 X 30 PLTD		
8	86222730	620038	1	PLATE, DRIVE WHEEL YOKE		
9	86318830	-	11	SCR, M10 X 30 SHCS		
10	86275640	70515	4	SCR, 3/8-24 X 3/4 HHCS GR5 PLTD		
11	86279700	87244	5	WASHER, M10 X 18 FLAT		
12	86219620	48106	1	KEY, 1/4 SQ. X .63		
13	86007620	730310	1	SPROCKET, MOTOR SHAFT		
14	86279710	87245	3	WASHER, M8 (2 THK X 26 OD)		
15	86136640	70262	2	SCR, M8-1.25 X 20HHMS PLTD		
16	86222710	620036	1	PLATE, CHAIN COVER		
17	86279690	87243	12	WASHER, M6 SPLIT LOCK BLK		
18	86277340	70830	12	SCR, M6 X 15 HHCS BLK		
19	86002730	270085	1	CHAIN, ISO 08B 12.7MM PITCH/LINK		
-	86232770	279000	-	CHAIN, OFF-SET LINK 12.7MM		SERVICE ONLY
-	86232780	279001	-	CHAIN, MASTERLINK 12.7MM		SERVICE ONLY
20	86222760	620041	1	PLATE, DRIVE YOKE RH		
21	86007630	730311	1	SPROCKET, DRIVE WHEEL		
22	86002710	270076	1	CHAIN TENSIONER		
23	86224270	730293	1	SLEEVE, CHAIN TENSIONER		
24	86277330	70829	1	SCR, M10 X 45 HHCS		
25	86222720	620037	1	PLATE, BEARING RETAINER		
26	86224330	730294	1	SPACER, 25.5ID X 45OD X 65L		
27	86219630	48107	1	KEY, 3/16 SQ X .67		
28	86000850	05231	1	AXLE, DRIVE		
29	86219640	48108	1	KEY, 1/4 SQ X 1.5		
30A	86011120	89262	1	WHEEL, 10X2.5X1.06 W/KEYWY		
30B	86259920	89273	1	WHEEL, 10X2.5 W/KEYWY GRY		OPTIONAL
31	86222750	620040	1	PLATE, DRIVE YOKE FRONT		
32	86224340	730295	1	SPACER, 25.5ID X 45OD X 43L		
33	86222770	620042	1	PLATE, BEARING COVER		
34	86217720	29269	-	DRIVE ASM, MOTOR		COMPLETE
35	86277320	70828	1	SCR, M10 X 30 HHCS		

WHEEL-FRONT DRIVE, GEAR

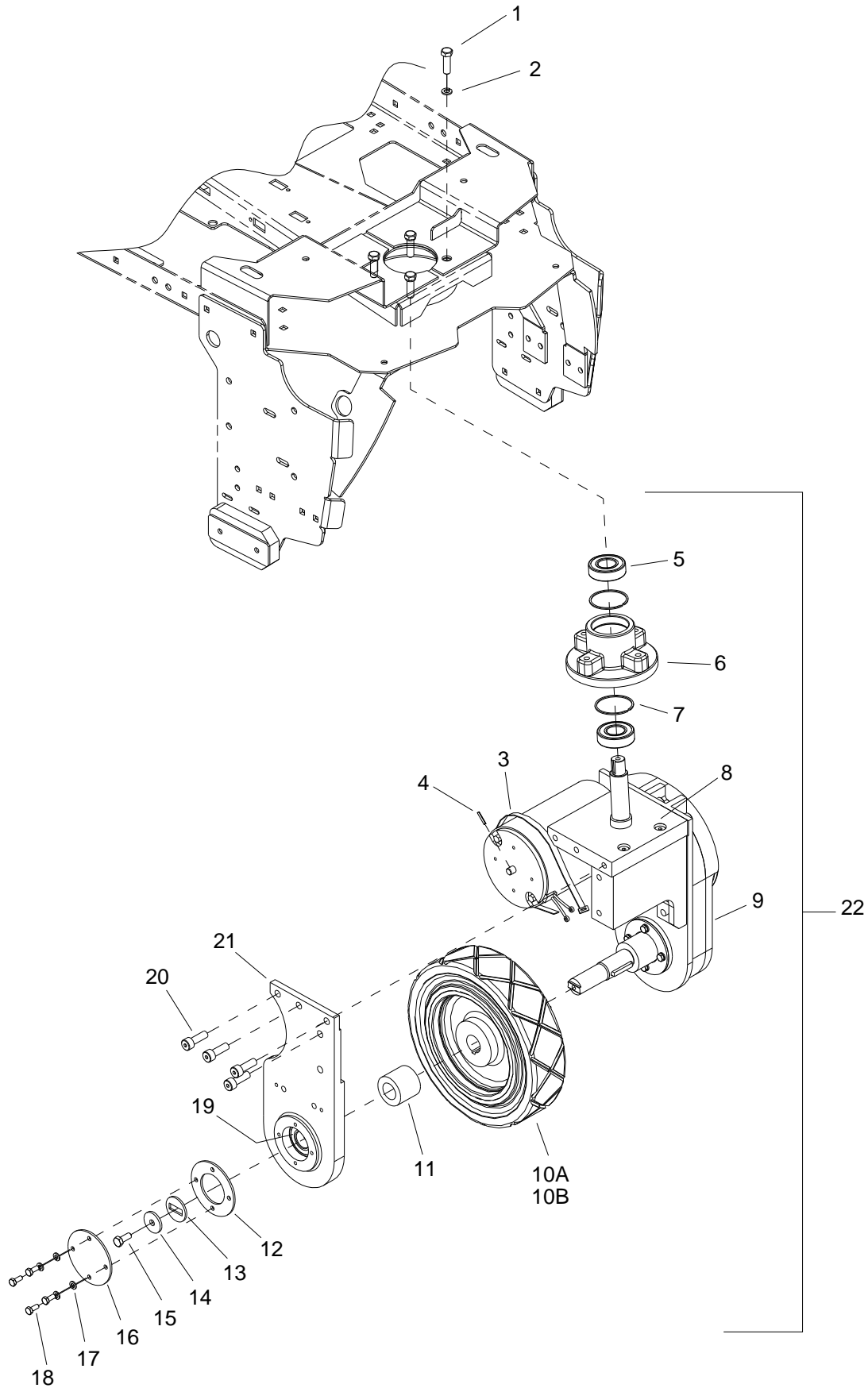

WHEEL-FRONT DRIVE, GEAR

REF	PART NO.	PRV NO.	QTY	DESCRIPTION	SERIAL NO. FROM	NOTES:
1	86275190	70377	4	SCR, 3/8-16 X 1.25 HHCS SS		
2	86010790	87163	4	WASHER, 3/8 SPLIT LOCK PLTD		
3	86002830	27196	1	CABLE TIE, .375 X 24.7		
4	86006170	66031	1	PIN, ROLL 1/8" X 3/4"L		
5	86223980	09134	3	SEALED BALL BRNG, 25MM X 52MM		
6	86219420	41510	1	HUB STEERING		
7	86223480	67450	2	RING, 52MM INTERNAL SNAP		
8	86224020	730233	1	SHAFT ASM, DRIVE PIVOT		
9	86317190	-	1	GEAR BOX DRIVE UNIT HELICAL		
10A	86011120	89262	1	WHEEL, 10 X 2, 5 X 1.06 W/KEYWAY		
10B	86259920	89273	1	WHEEL, 10 X 2. 5 W/KEYWAY, GRY		OPTION
11	86224440	730387	1	SPACER, 25.51 ID X 45 OD X 39.1 L		
12	86222720	620037	1	PLATE, BEARING RETAINERX		
13	86225810	87506	1	WASHER, ANTI-ROTATION		
14	86279710	87245	1	WASHER, M8 (2THK X 26 OD)		
15	86136640	70262	1	SCR, M8-1.25 X 20 HHMS PLTD		
16	86222770	620042	1	PLATE, BEARING COVER		
17	86279690	87243	4	WASHER, M6 SPLIT LOCK BLK		
18	86277340	70830	4	SCR, M6 X 15 HHCS BLK		
19	86223980	09134	3	SEALED BALL BRNG, .25MM X 52MM		
20	86318830	-	10	SCR, M10 X 30 SHCS		
21	86222760	620041	1	PLATE, DRIVE YOKE RH		
22	86317200	-	1	DRIVE MOTOR ASSEMBLY HELICAL		WHEEL NOT INCLUDED
-	86216210	53820	-	BRUSH SET MOTOR, 53810 86005510		

*SEE SERIAL NUMBER PAGE.

WHEEL-FRONT BRAKE

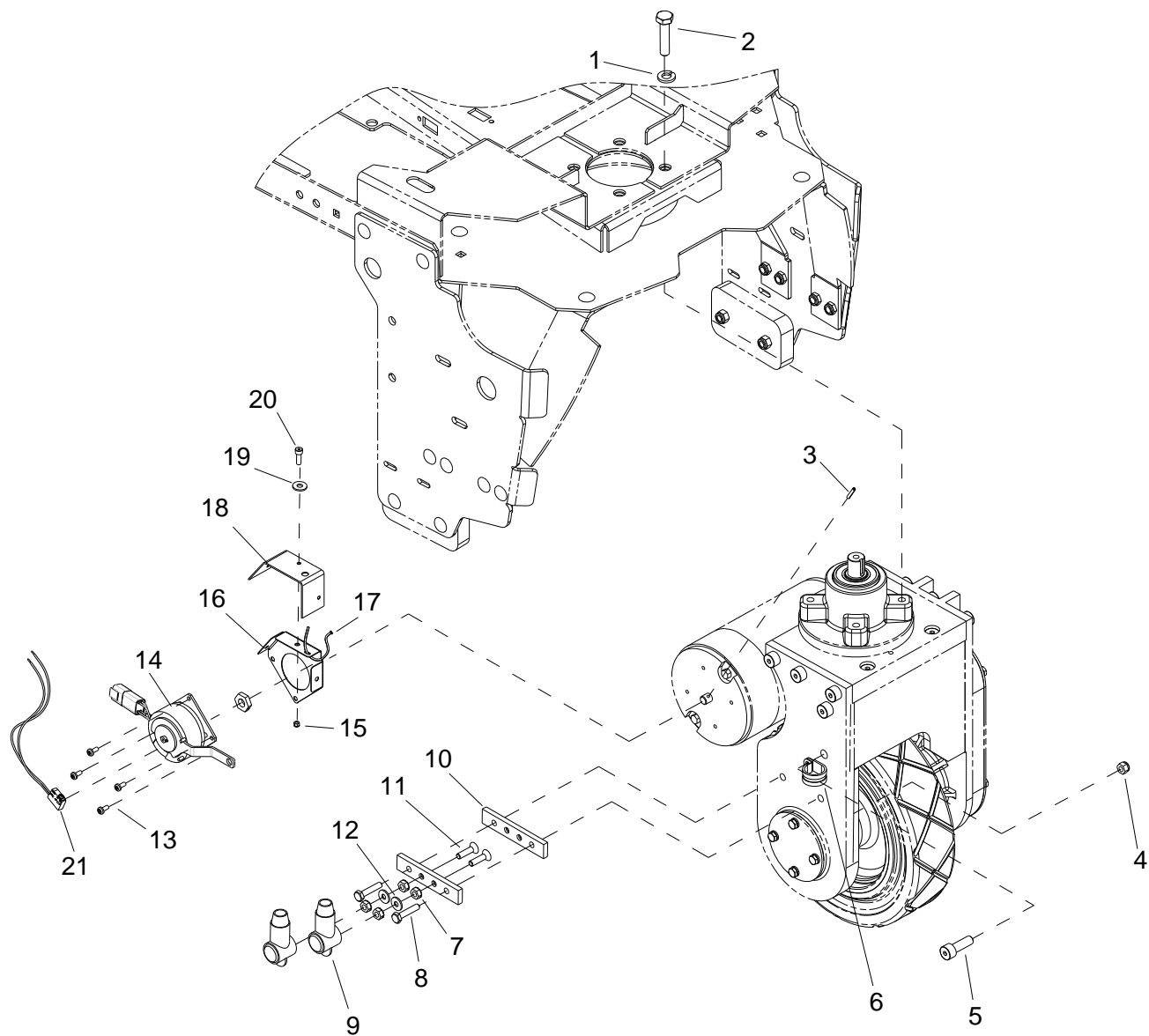

WHEEL-FRONT BRAKE

REF	PART NO.	PRV NO.	QTY	DESCRIPTION	SERIAL NO. FROM	NOTES:
1	86010790	87163	4	WASHER, 3/8 SPLIT LOCK PLTD		
2	86275190	70377	4	SCR, 3/8-16 X 1.25 HHCS SS		
3	86006170	66031	1	PIN, ROLL 1/8" X 3/4"L SS		
4	86005810	57245	2	NUT, 1/4-20 HEX NYLOCK SS		
5	86318830	-	1	SCR, M10 X 30 SHCS		
6	86233410	81270	1	CLAMP, 3/4 DIA CUSHION .406DIA		
7	86005710	57105	4	NUT, 1/4-20 HEX W/STAR WASHER		
8	86273740	70010	2	SCR, 1/4-20 X 1.50 HHCS		
9	86008920	80889	2	BOOT, RUBBER TERM. ISOLATOR		
10	86257490	76155	2	TERMINAL MOUNT		
11	86006840	70390	2	SCR, 1/4-20 X 1 FHCS PLTD		
12	86010630	87013	2	WASHER, 1/4 ID X 5/8 OD SS		
13	86273340	00-000289	4	SCR, 8-32 X 3/8 SHCS SS		
14	86001740	140816	1	BRAKE, 36VDC W/CONNECTOR		
15	86270990	57090	3	NUT, 10-32 HEX NYLOCK SS	*(24)	
16	86301950		1	PLATE, BRAKE SPACER	*(24)	
17	86264930	27050	1	CABLE TIE, 3.5" UL/CSA		
18	86301960		1	SKIRT, BRAKE	*(24)	
19	86010650	87018	3	WASHER, #10 X 9/16 OD	*(24)	
20	86274290	70162	3	SCR, 10-32 X 3/8 PPHMS SS	*(24)	
21	86320870	-	1	SWITCH, 36V BRAKE		

* SEE SERIAL NUMBER PAGE.

WHEEL-REAR

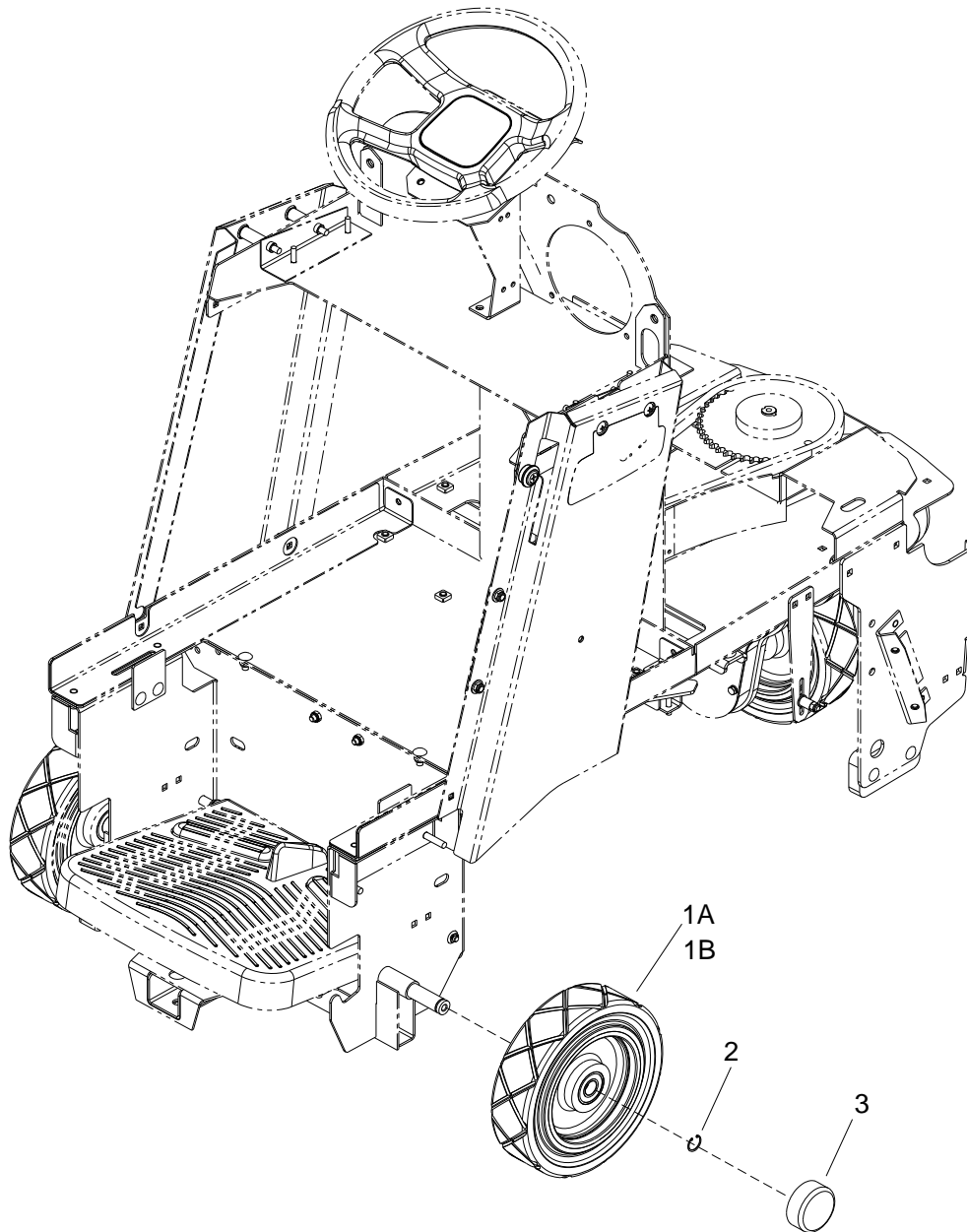

WHEEL-REAR

REF	PART NO.	PRV NO.	QTY	DESCRIPTION	SERIAL NO. FROM	NOTES:
1A	86011110	89261	2	WHEEL, 10X2.5X.787ID BEARINGS		
1B	86259930	89274	-	WHEEL, 10X2.5, W/BEARINGS, GRY		OPTIONAL
2	86008710	80623	2	RING, 3/4" EXT SNAP H-D		
3	86232130	17309	2	CAP, 2.75 ID X 1.0 L BLK VINYL		

WIRING-BATTERIES

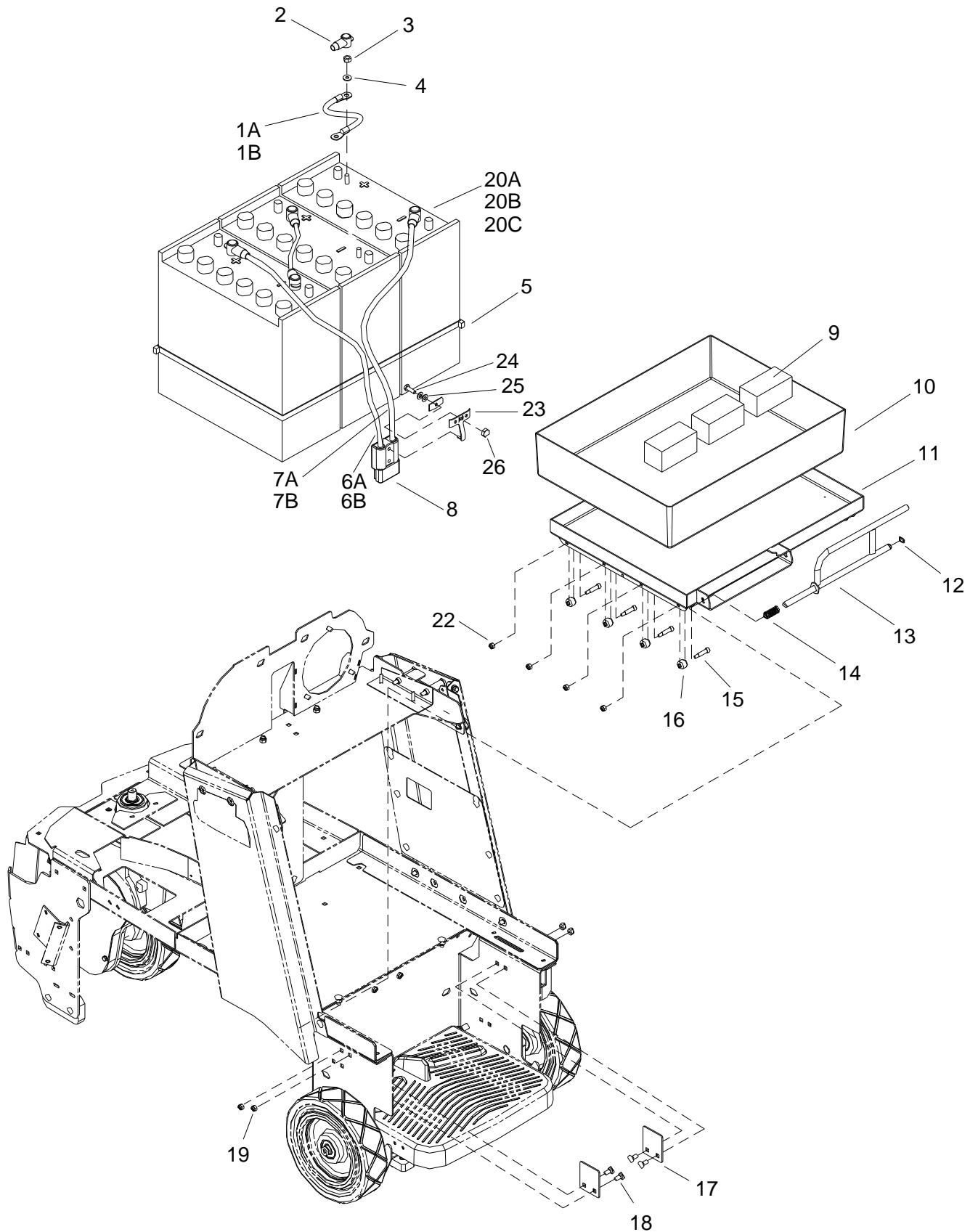

WIRING-BATTERIES

REF	PART NO.	PRV NO.	QTY	DESCRIPTION	SERIAL NO. FROM	NOTES:
1A	86260200	80872	2	WIRE, 4X14.5BK 3/8RINGX3/8RING		
1B	86002510	23125	2	CABLE ASM, BAT. JUMPER X 15"		
2	86008920	80889	6	BOOT, RUBBER TERM. ISOLATOR		
3	86271910	57295	6	NUT, 5/16-18 FLEXLOCK		
4	86010670	87029	6	WASHER, 5/16 FLAT SS		
5	86264960	27915	2	CABLE TIE, .375 X 43"		
6A	86260610	880836	1	WIRE, 4X25RD CTERM X 3/8RING	*(20)	
6B	86002570	23190	1	WIRE, 4X27 RD BCLAMP X CTERM		
7A	86260230	80876	1	WIRE, 4X30 BK CTERM X 3/8RING		
7B	86002580	23191	1	WIRE, 4X27 BK BCLAMP X CTERM		
8	86008760	80682	1	CONN, 175 DCA GRY W/O TERMS		
9	86229700	08071	3	BLOCK, 3.0 X 1.5 X 1.5		
10	86008300	78242	1	TRAY, BATTERY LINER		
11	86008410	78568	1	TRAY, BATTERY		
12	86272810	67132	1	RING, 1/2 EXT. SNAP H-D		
13	86092910	51396	1	LATCH ROD, BATTERY TRAY		
14	86254990	730313	1	SPRING, COMP, 63ODX3.5LX.047W		
15	86278150	70117	8	SHOULDER BOLT, 5/16 OD X 1.0 L		
16	86259910	89265	8	WHEEL, BATTERY TRAY		
17	86088790	78571	2	TRAY, STANDARD STOP		
18	86276070	70593	4	SCR, 5/16-18 X 3/4 CARRIAGE SS		
19	86270830	57023	4	NUT, 5/16-18 HEX NYLOCK SS		
20A	86228410	10023	3	BATTERY, 12V, 205AH		
20B	86283410	10030	3	BATTERY, 12V, 225AH		
20C	86228430	10032	3	BATTERY, 12V, AGM 198AH		
21A	86284090	02456	1	CHARGER, 36V, 20A, 115V, C175		▲
21B	86000150	02264	1	CHARGER, 36VDC/21A AGM		▲
22	86005810	57245	8	NUT, 1/4-20 HEX NYLOCK SS		
23	86233360	28038	1	CLAMP, CABLE KIT SY945	*(12)	
24	86273980	70066	1	SCREW, 10-32 X 3/4 PPHMS SS		
25	86010650	87018	1	WASHER, #10 X 9/16 OD		
26	86270890	57034	1	NUT, ACORN 10-32		

▲ NOT SHOWN – FOR WET CELL BATTERIES AND AGM BATTERIES

* SEE SERIAL NUMBER PAGE

WIRING-COMPONENTS

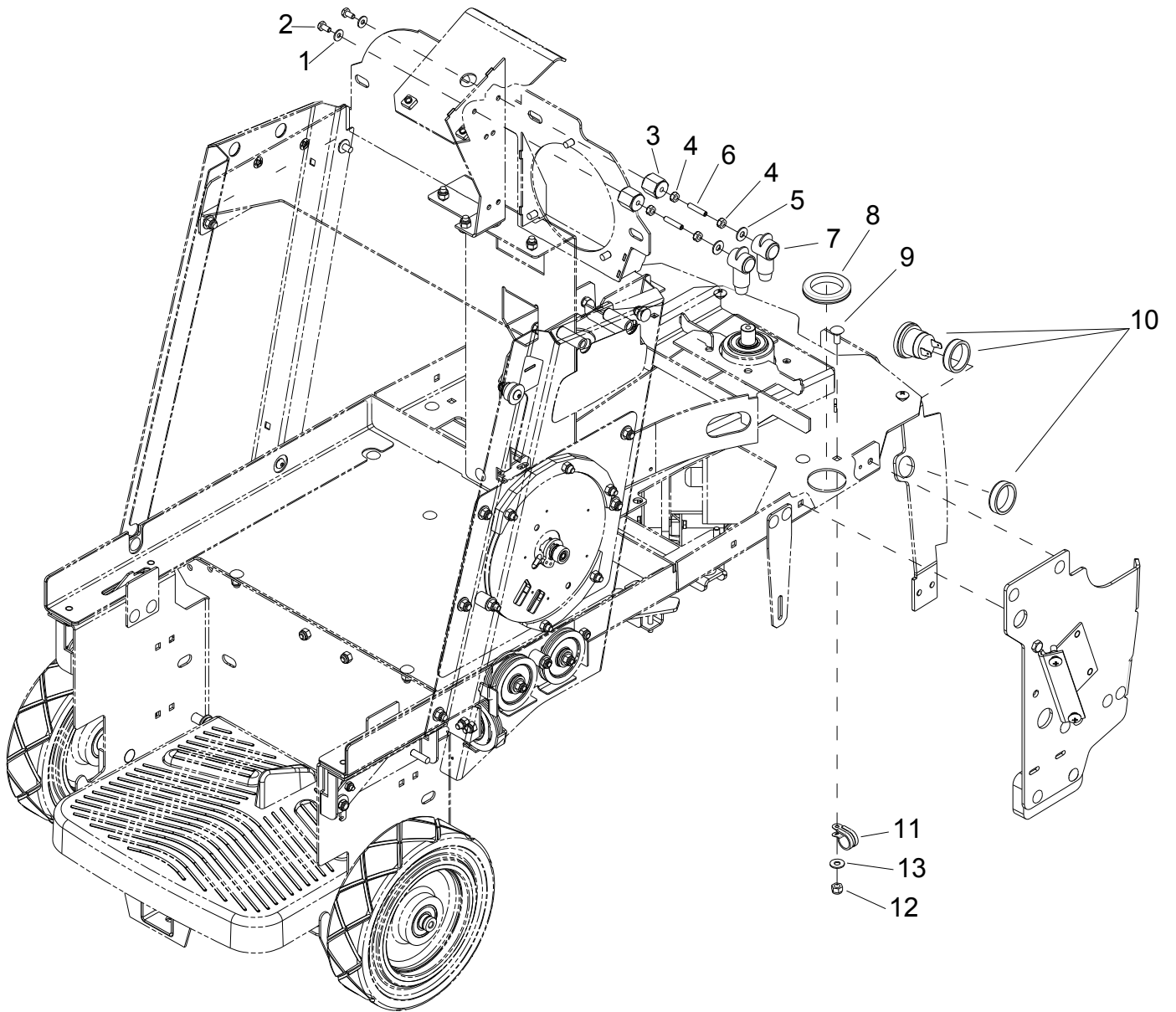

WIRING-COMPONENTS

REF	PART NO.	PRV NO.	QTY	DESCRIPTION	SERIAL NO. FROM	NOTES:
1	86010780	87162	2	WASHER, 1/4 SPLIT LOCK PLTD		
2	86273830	70020	2	SCR, 1/4-20 X 1/2 HHCS SS NP		
3	86255910	73659	2	STANDOFF, 1/4-20 X 1.0 HEX INS		
4	86005710	57105	4	NUT, 1/4-20 HEX W/STAR WASHER		
5	86010630	87013	2	WASHER, 1/4 ID X 5/8 OD SS		
6	86006850	70393	2	SET SCR, 1/4-20 1.25L		
7	86008920	80889	2	BOOT, RUBBER TERM. ISOLATOR		
8	86238500	81427	1	GROMMET, 1.703IDX2.5ODX.125GRV		
9	86276070	70593	1	SCR, 5/16-18 X 3/4 CARRIAGE SS		
10	86239720	41520	1	HORN, 108DB MINIATURE PIEZO		
11	86233410	81270	1	CLAMP, 3/4 DIA CUSHION .406DIA		
12	86270830	57023	1	NUT, 5/16-18 HEX NYLOCK SS		
13	86010670	87029	1	WASHER, 5/16 FLAT SS		

WIRING-CONTROL PANEL-BASIC-CYLINDRICAL

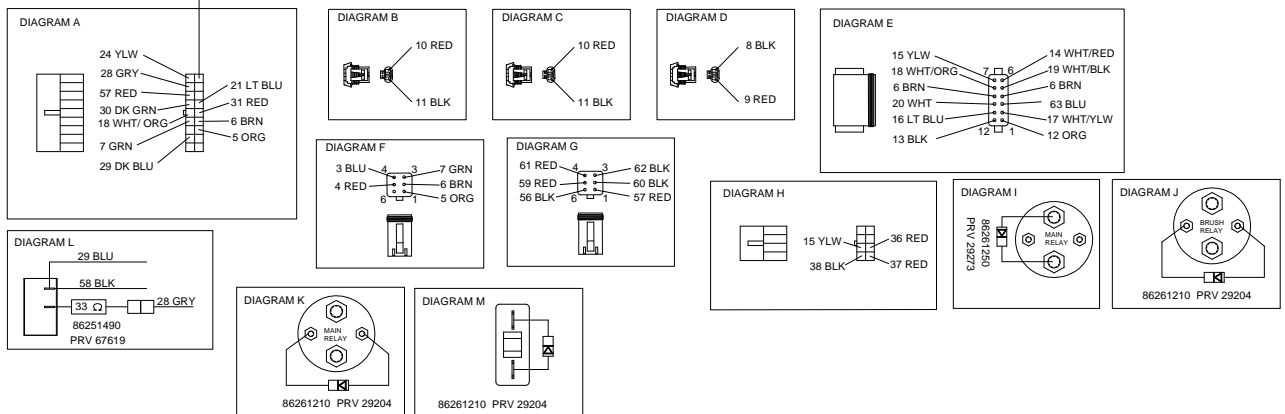
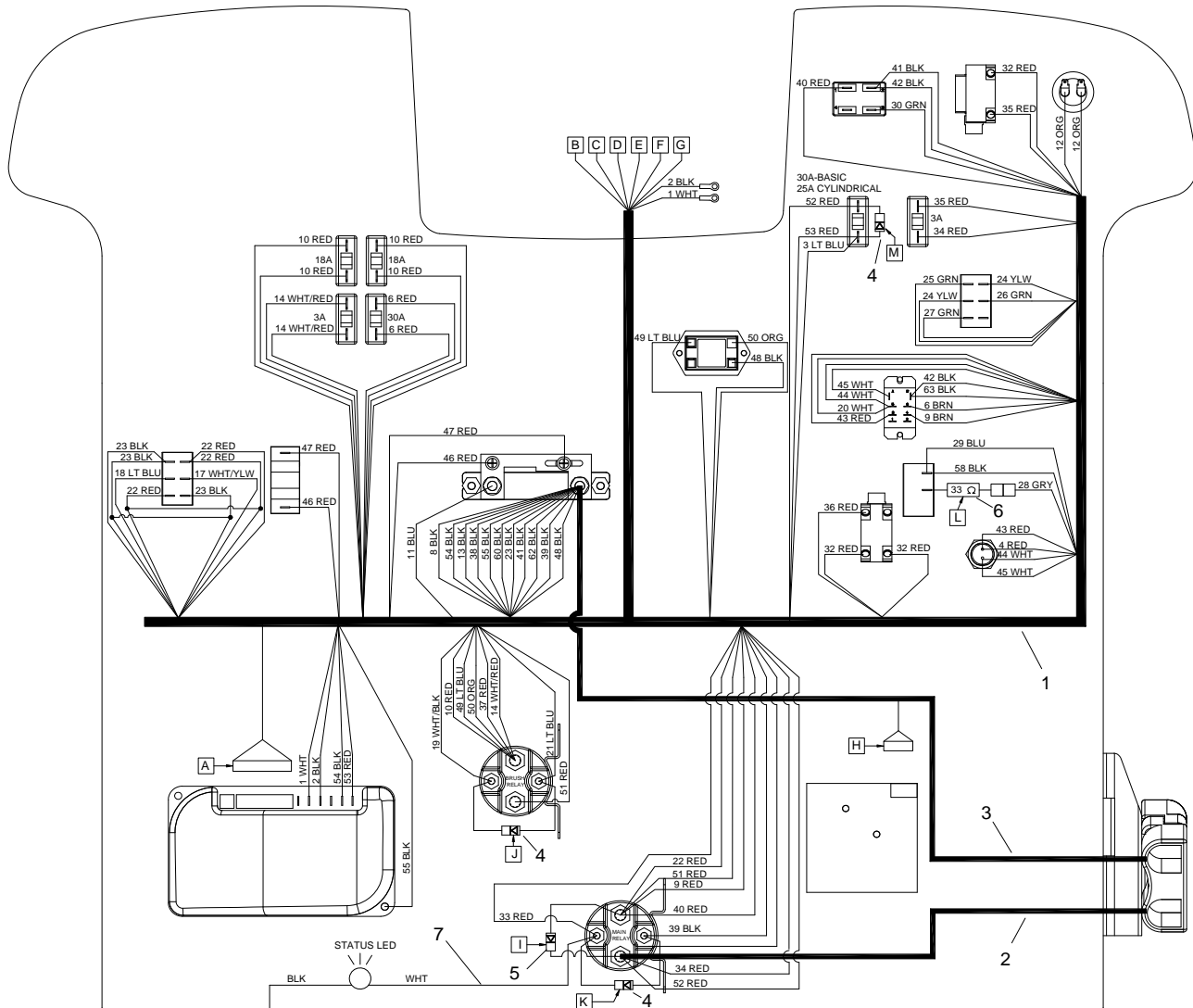

WIRING-CONTROL PANEL- BASIC - CYLINDRICAL

REF	PART NO.	PRV NO.	QTY	DESCRIPTION	SERIAL NO. FROM	NOTES:
1	86239140	41524	1	HARNESS, CONTROL PANEL BASIC		
2	86260540	880426	1	WIRE, 4X13 RD C.TERM X 5/16RING		
3	86010860	880353	1	WIRE, 4X20 BK CTERM X5/16RING		
4	86261210	29204	3	DIODE ASM, 76008, 76008		
5	86261250	29273	1	DIODE ASM, FAST RECOVERY	*(8)	
6	86251490	67619	1	RESISTOR ASM, 1/2 WATT 33 OHM	*(18)	
7	86311210	-	1	LIGHT ASM, INDICATOR, CODE		

* SEE SERIAL NUMBER PAGE

WIRING-CONTROL PANEL-DELUXE

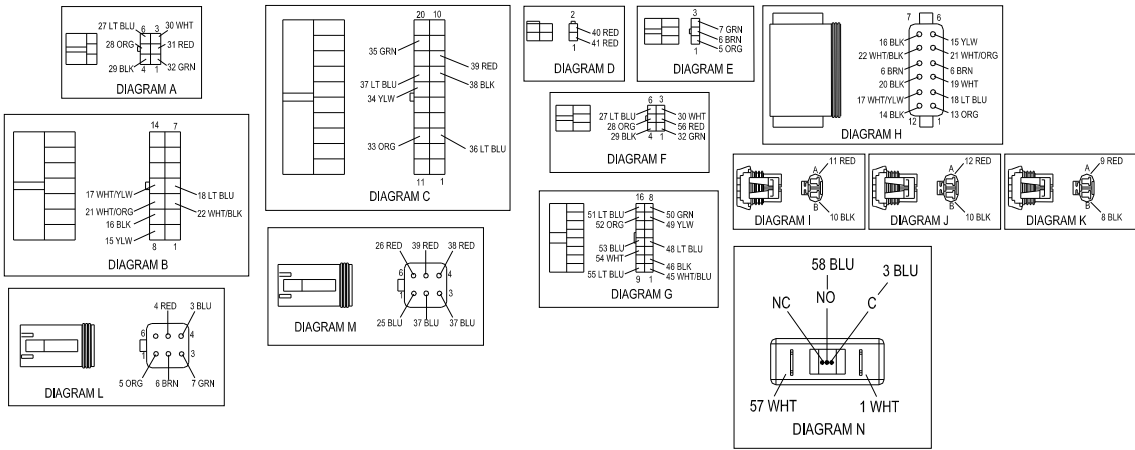
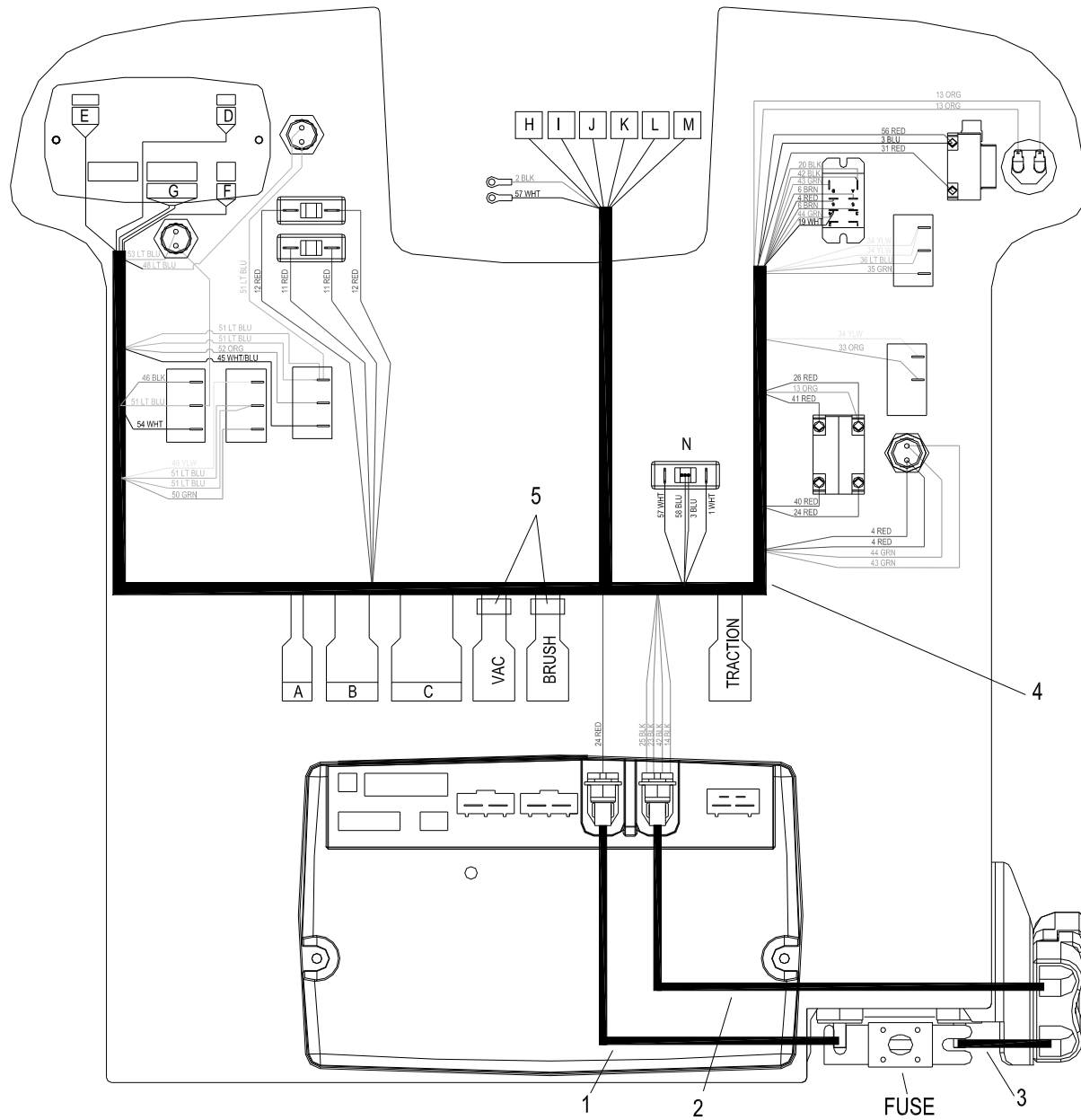

WIRING-CONTROL PANEL-DELUXE

REF	PART NO.	PRV NO.	QTY	DESCRIPTION	SERIAL NO. FROM	NOTES:
1	86260560	880428	1	WIRE, 4X10RD 5/16RING X 5/16RING		
2	86260550	880427	1	WIRE, 4X15BK C. TERM X 5/16 RING		
3	86260570	880429	1	WIRE, 4X8RD C. TERM X 5/16RING		
4	86239150	41525	1	HARNESS, CONTROL PANEL DELUXE		
5	86235780	34164	2	FERRITE CLAMP, 1.14 X 1.28 X .583		CSXE24 & CSXEO24 ONLY

WIRING- DRIVE MOTOR

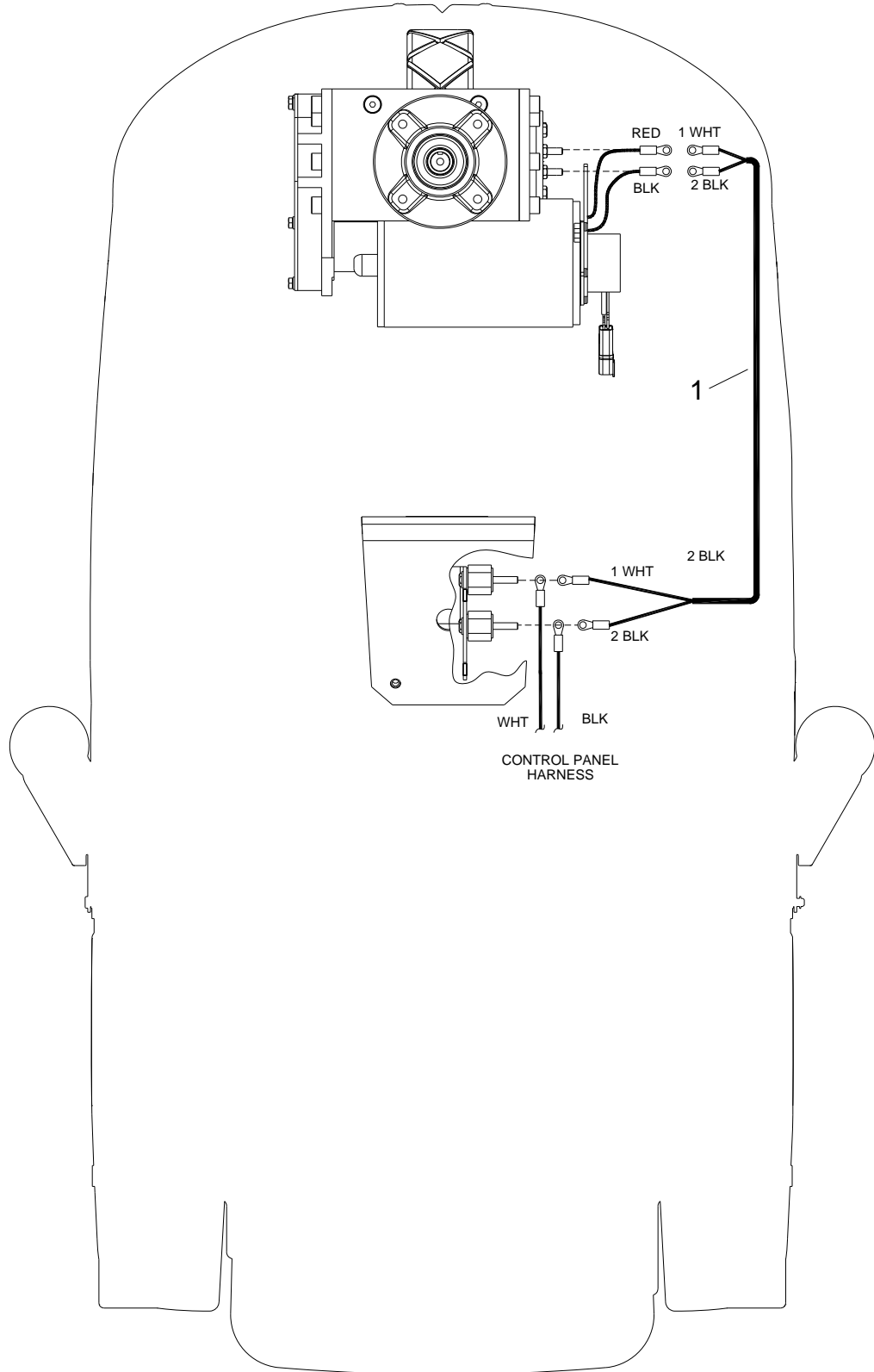

WIRING-DRIVE MOTOR

REF	PART NO.	PRV NO.	QTY	DESCRIPTION	SERIAL NO. FROM	NOTES:
1	86239120	41522	1	HARNESS, CHARIOT PROPEL		

WIRING-MAIN HARNESS

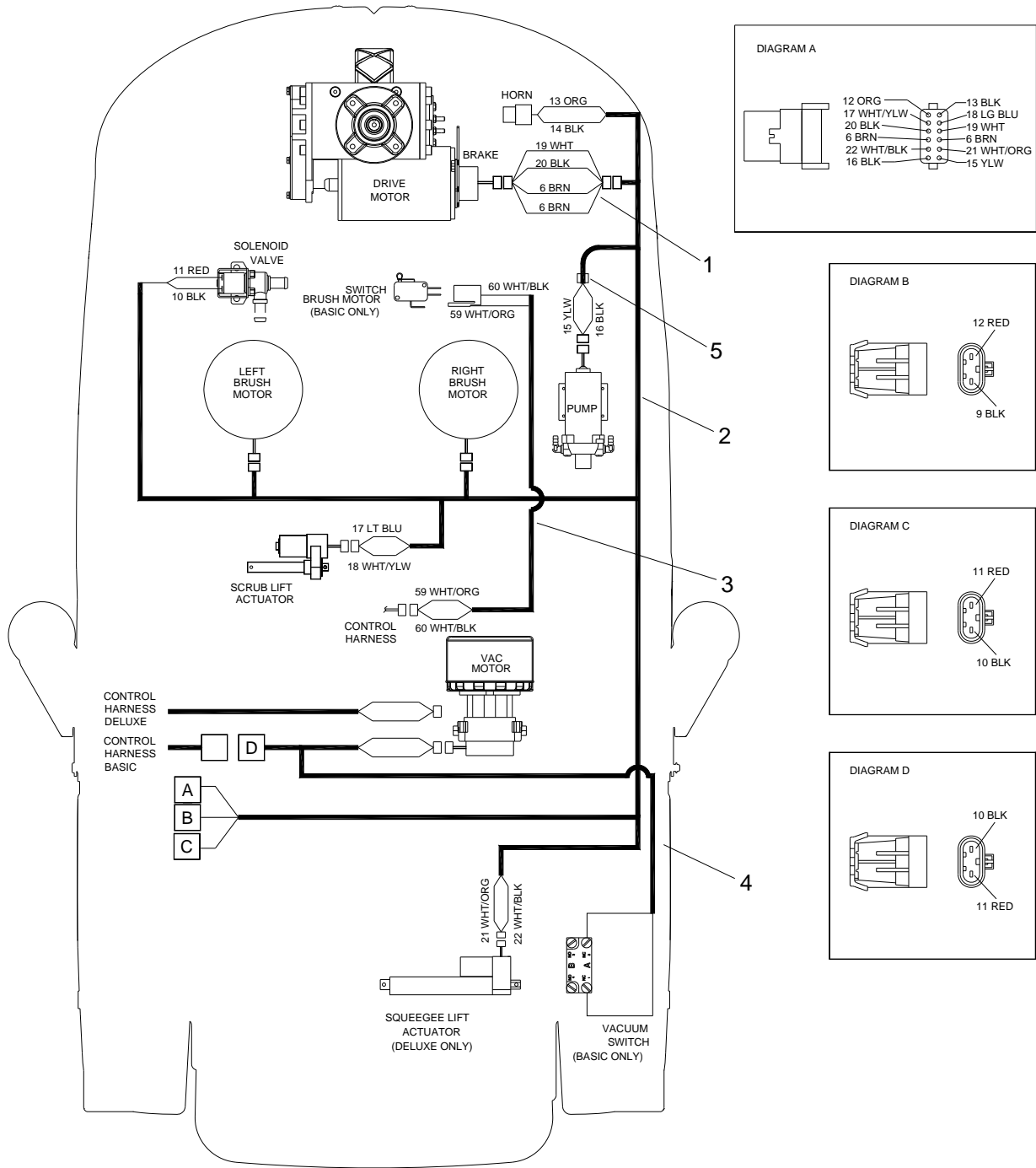

WIRING-MAIN HARNESS

REF	PART NO.	PRV NO.	QTY	DESCRIPTION	SERIAL NO. FROM	NOTES:
1	86239170	41528	1	HARNESS, BRAKE		
2	86239130	41523	1	HARNESS, MAIN		
3	86239160	41527	1	HARNESS, DECK SWITCH		BASIC ONLY
4	86239110	41521	1	HARNESS, VAC BASIC		BASIC ONLY
5	86235820	34376	1	FERRITE, .72 X .70 X 1.28		CSE24 ONLY

WIRING-PEDAL PLATFORM

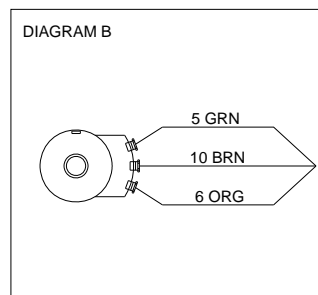
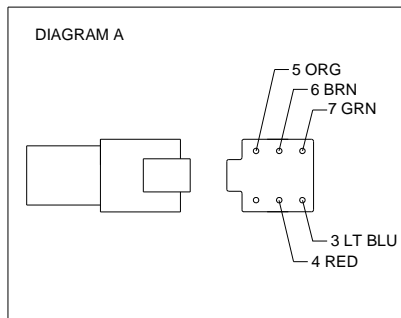
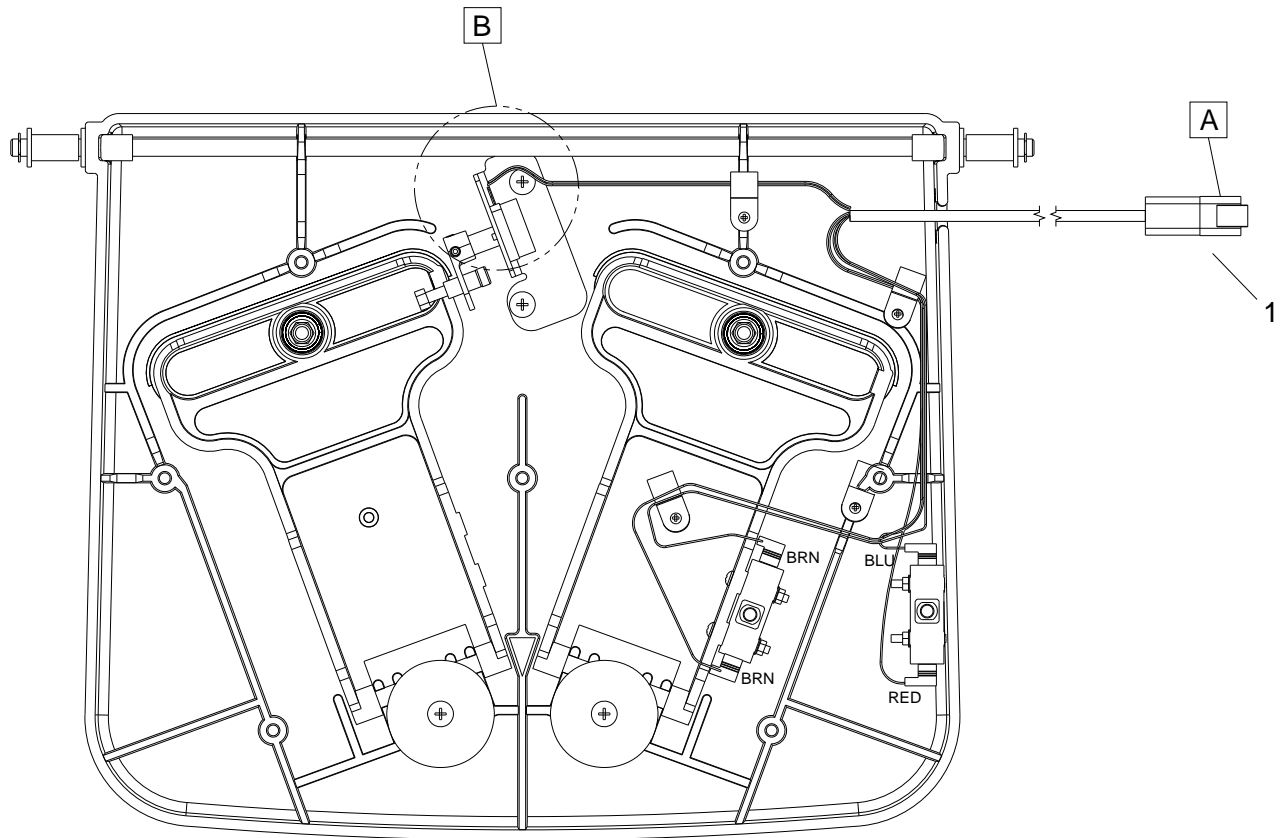

WIRING-PEDAL PLATFORM

REF	PART NO.	PRV NO.	QTY	DESCRIPTION	SERIAL NO. FROM	NOTES:
1	86218810	23717	1	HARNESS, TWISTER PEDAL		

WIRING DIAGRAM-BASIC-CYLINDRICAL

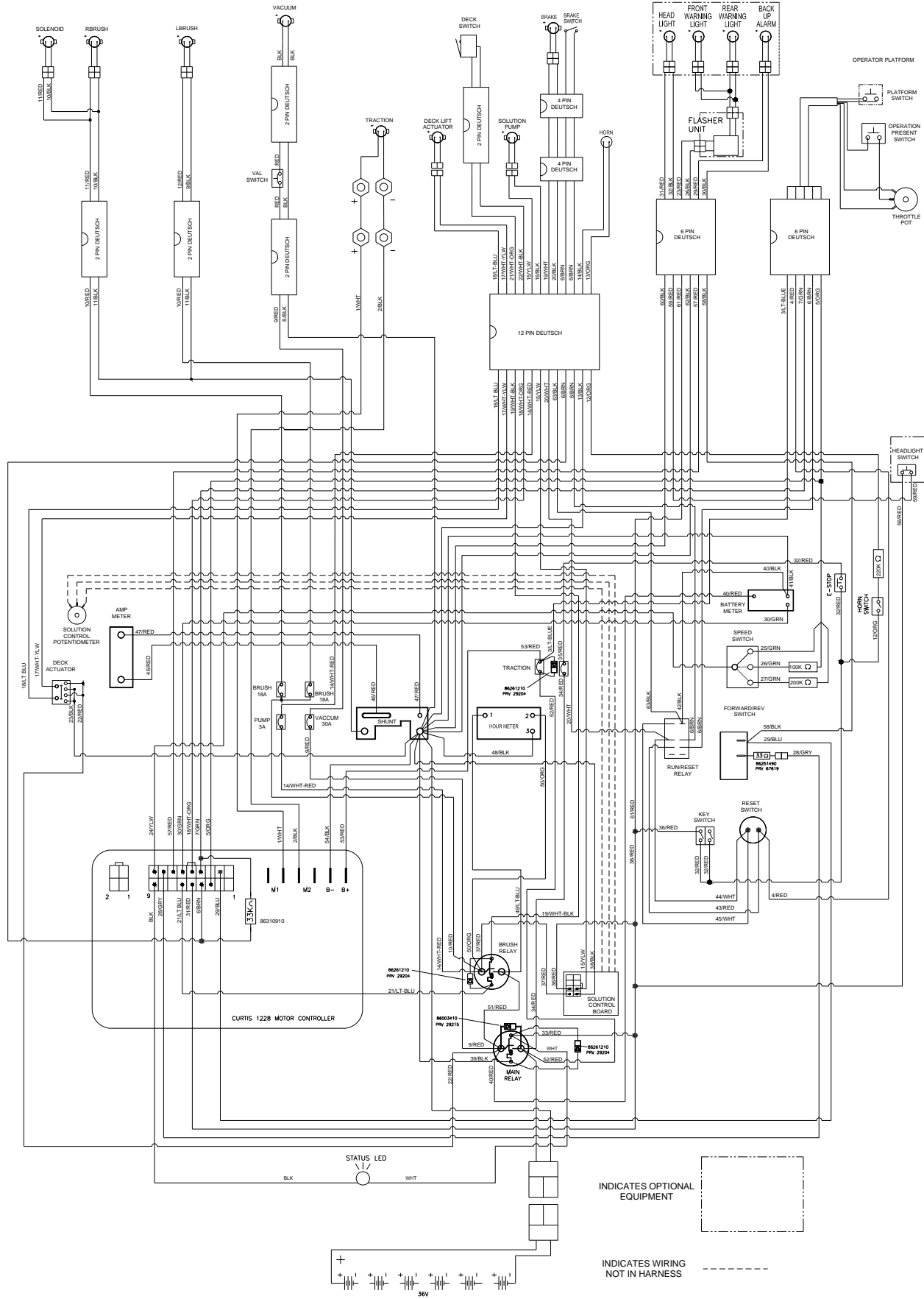

WIRING DIAGRAM-DELUXE

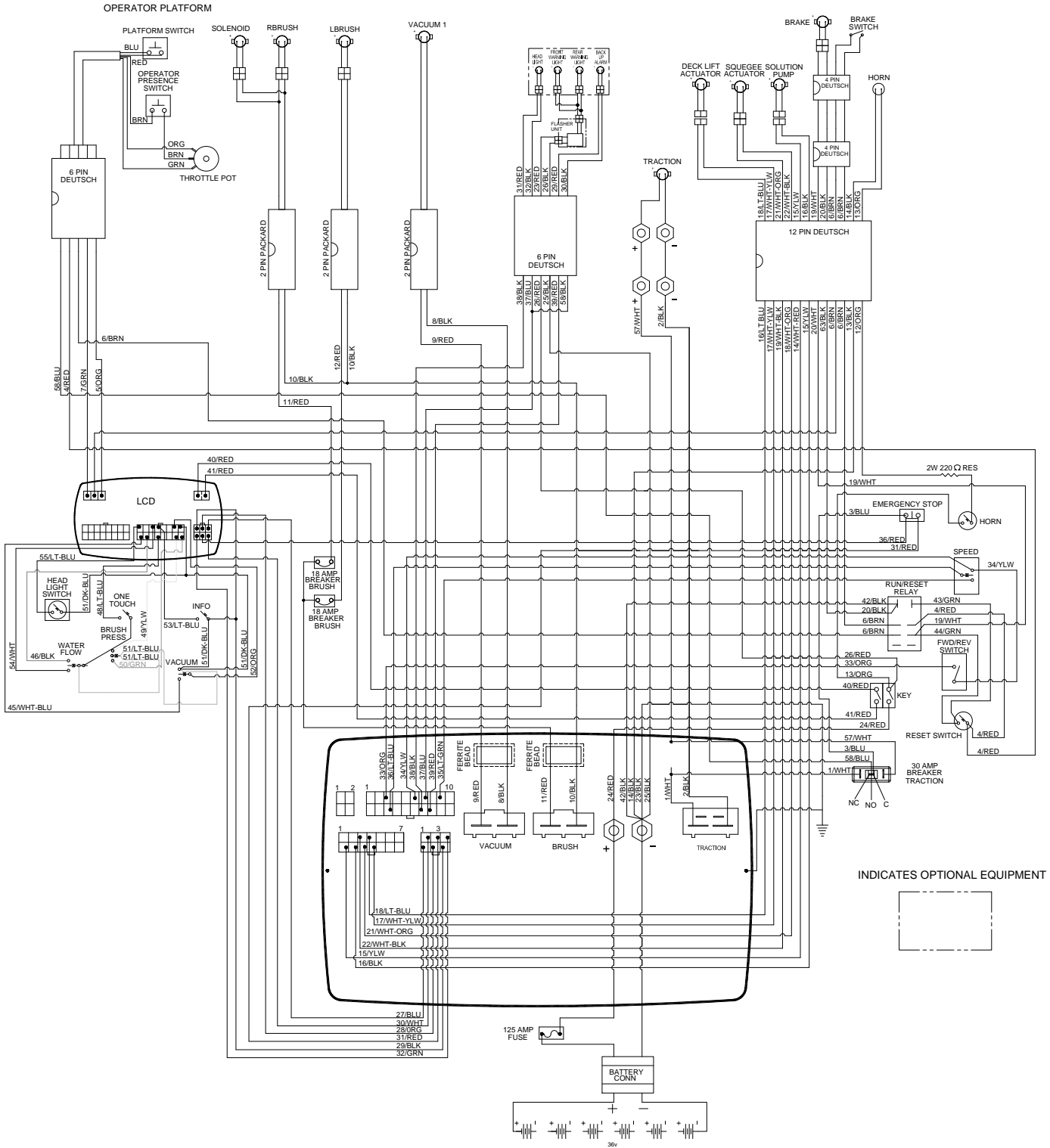

HOSE DIAGRAM - DISK

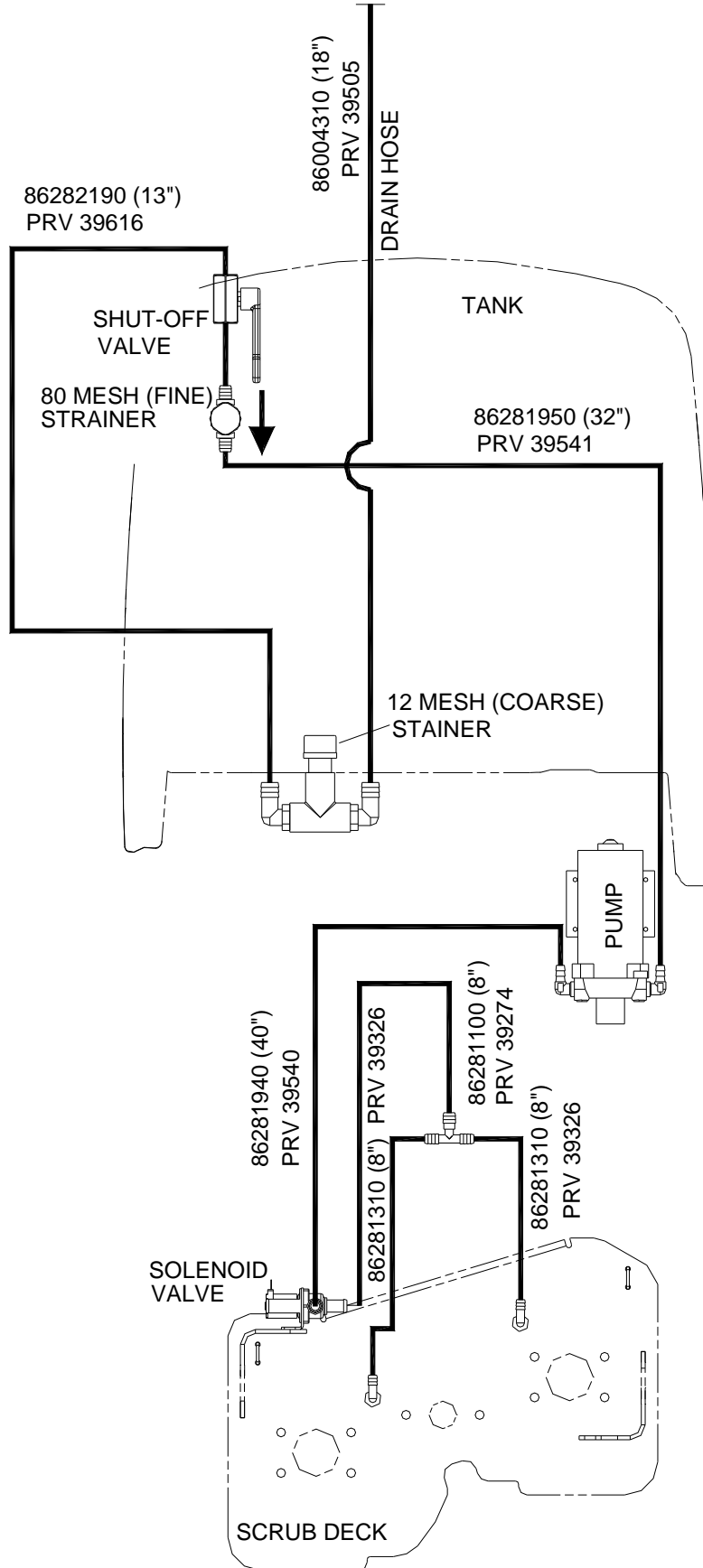

HOSE DIAGRAM - CYLINDRICAL

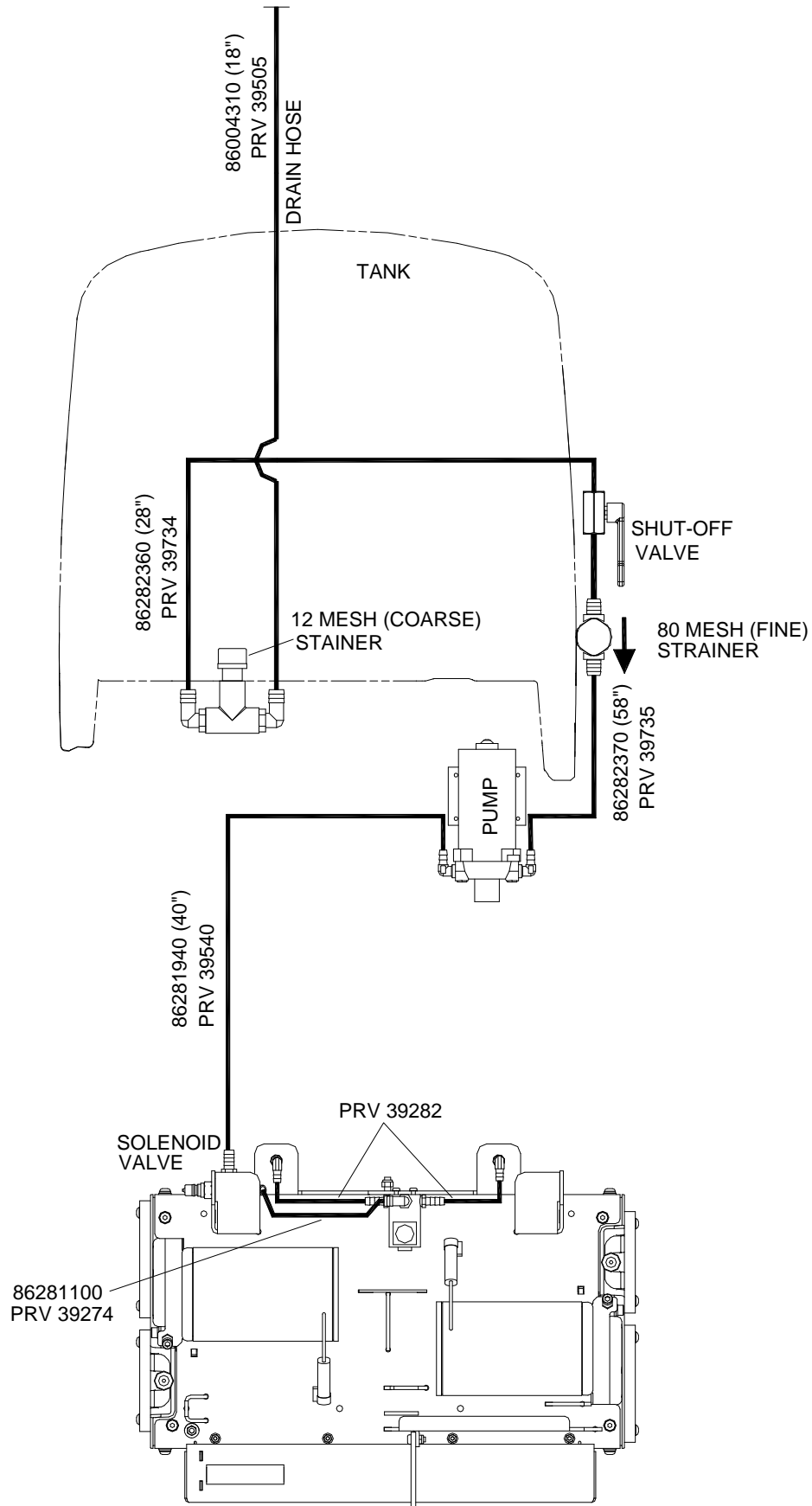

SUGGESTED SPARE PARTS

PART NO.	PRV NO.	DESCRIPTION	SERIAL NO. FROM	NOTES:
86001910	14606	BREAKER, 30A 50VDC CIRCUIT		BASIC ONLY
86001920	14607	BREAKER, 25BA 50VDC CIRCUIT		BASIC ONLY
86002000	14717	BREAKER, 3 AMP 1681-090-300		BASIC ONLY
86002010	14942	BOOT, 3/8 CIRCUIT BREAKER		
86232130	17309	CAP, 2.75 X 1.0L BLACK VINYL		
86003680	34380	FLOAT, SHUT OFF		
86004010	35274	GASKET, DOME EDGE		
86305960	-	HOSE ASM., 1.5" BLK PVC VAC X 67		
86004860	48073	KEY, SWITCH		
86004890	48095	KNOB, ALUM 3/8-16 NYLOCK NUT SS		
86006340	66347	RECOVERY DRAIN PLUG 1-3/4		
86251410	67506	RELAY, 15A 36V MINI		
86007140	72130	SWITCH, SPST 2-POSITION ROCKER		
86007170	72159	SWITCH, 2 POSITION KEY		BASIC ONLY
86007190	72161	SWITCH, DPST KEY		DELUXE ONLY
86007240	72190	SWITCH, SEALED PB ROUND		
86008790	80687	FUSE, 125 AMP		
86009200	81535	KNOB, 3/8-16 4 PRONG ALUM		
86009700	82267	PLUG, 5/8" DRAIN HOSE		
86069880	140534	BRKT, CABLE ATTACH		DELUXE ONLY
86001510	140712	BAG, INNER TANK		
86001520	140752	BLADE, AQUAMIZER, 12IN LEFT		
86001540	140753	BLADE, AQUAMIZER, 12IN RIGHT		
86001560	140754	BLADE, SKIRT, SCRUB DECK, 24 IN LEFT		
86001570	140755	BLADE, SKIRT, SCRUB DECK, 24 IN RIGHT		
86001580	140763	BLADE, SQG REAR 40.6IN LINATEX		
86001630	140764	BLADE, SQG FRONT 36.7IN RED GUM		
86001700	140780	BLADE, SKIRT, SCRUB DECK, FRONT		
86001730	140804	BREAKER, 18A 250VAC, 50VDC		
86001740	140816	BRAKE, 36 VDC W/CONNECTOR		
86002730	270085	CHAIN, ISO 08B 12.7 MM PITCH		
86231560	270097	CABLE, SQUEEGEE LIFT BASIC		
86002780	270098	CABLE, SQUEEGEE LIFT DELUXE		
86007940	73836	STRAINER, DEEP, 100 MESH		DISK ONLY
86256120	730368	STRAINER, 1/2 FPT 100 MESH		CYLINDRICAL ONLY
86313170	-	CAP, STRAINER TALL		

The logo features the word "chariot" in a bold, italicized, sans-serif font. The letter "h" is stylized with horizontal lines passing through it, and the letter "i" is also stylized with horizontal lines. A horizontal line extends from the left side of the "c" across the entire word.

chariot

OPTIONS

BACK-UP ALARM - OPTION

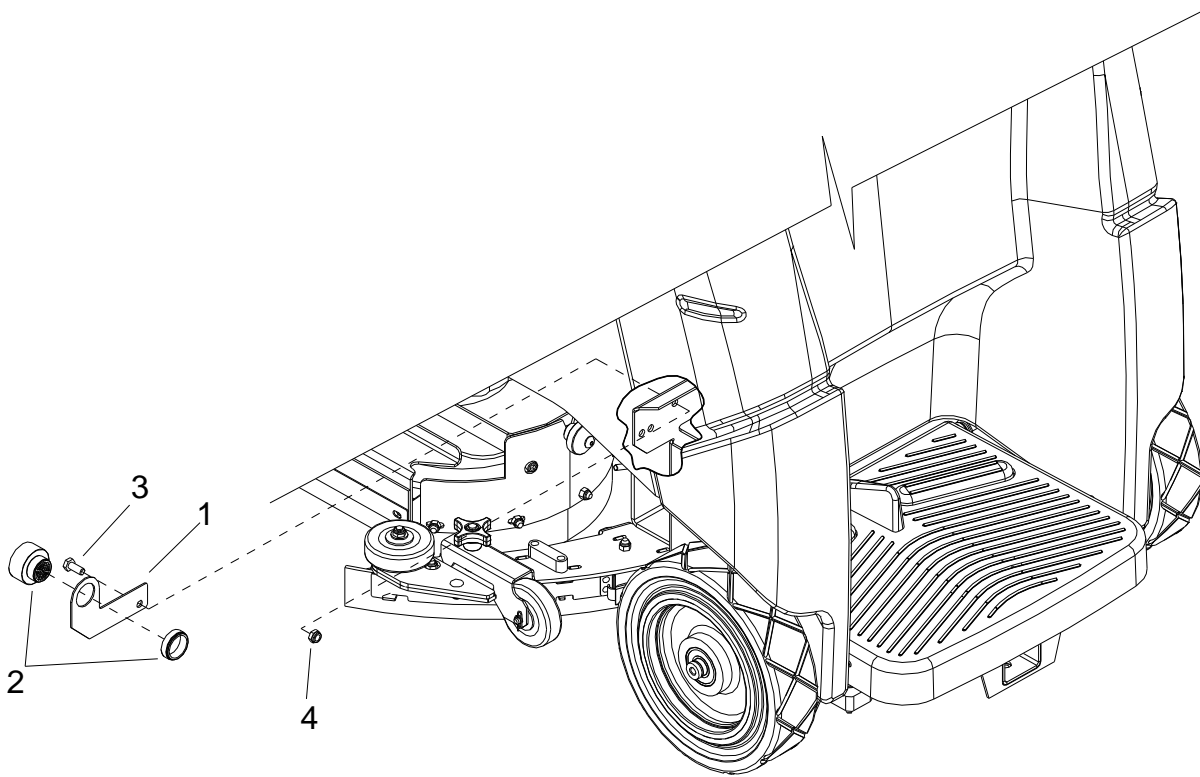

BACK-UP ALARM - OPTION

REF	PART NO.	PRV NO.	QTY	DESCRIPTION	SERIAL NO. FROM	NOTES:
1	86071140	140817	1	BRKT, BACK UP ALARM		
2	86231500	80882	1	BUZZER, PIEZO 6-28VCD		
3	86276780	70728	1	SCR, 5/16-18 X 3/4 HHCS SS		
4	86271840	57285	1	NUT, 5/16-18 HEX NYLOCK THN SS		

BATTERY CART - OPTION

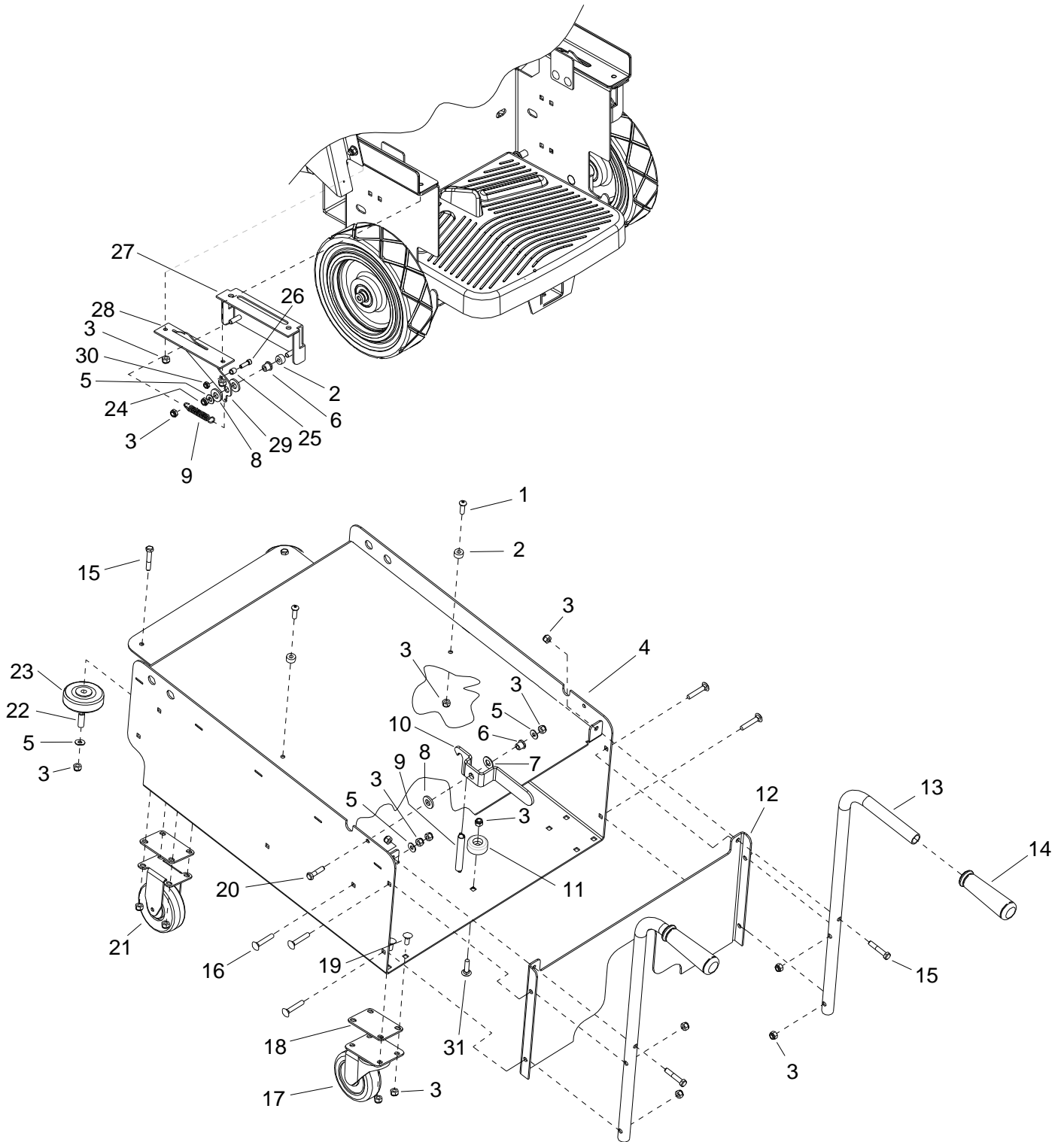

BATTERY CART - OPTION

REF	PART NO.	PRV NO.	QTY	DESCRIPTION	SERIAL NO. FROM	NOTES:
1	86006930	70514	2	SCR, 5/16-18 X 1.00 BSHCS SS		
2	86254290	730338	4	SPACER, 10D X .343ID, .5 LG		
3	86270830	57023	33	NUT, 5/16-18 HEX NYLOCK SS		
4	86077010	41517	1	HOUSING, BATTERY CART		
5	86010670	87029	7	WASHER, 5/16 FLAT SS		
6	86228840	09124	3	BEARING, FLANGED .314D X .502OD		
7	86259410	87206	1	WASHER, THRUST, .51 ID X 1 OD X .063		
8	86259400	730331	4	WASHER, THRUST .51 ID X 1 OD		
9	86254890	730018	3	SPRING, EXT, .50D X 4.0L		
10	86068490	140019	1	BRKT, TRAY CATCH		
11	86231090	80809	1	BUMPER, RUBBER 5/16" ID X 1.50		
12	86083120	66442	1	PLATE, BATTERY CART BACK		
13	86076600	38318	2	HANDLE, BATTERY CART		
14	86004070	36196	2	GRIP, POLISHER HANDLE		
15	86276790	70732	4	SCR, 5/16-18 X 1.75 HHCS SS		
16	86276690	70715	7	SCR, 5/16-18 X 1.75 CARR SS		
17	86199430	040-03	2	CASTER SWIVEL 4" 250# CPCTY		
18	86078890	620020	8	PLATE, CASTER SPACER		
19	86277130	70795	16	SCR, 5/16-18 X 1.00 CARRIAGE SS		
20	86007020	70673	1	SP SCR, 5/16-18 X 1.25 HHCS SS NP		
21	86232590	18032	2	CASTER, 4" HARD RUBBER RIGID		
22	86001350	140390	2	BUSHING, SPANNER .435 X 1.10		
23	86011020	89202	2	WHEEL, 3" DIA CUSHION RUBBER		
24	86271840	57285	2	NUT, 5/16-18 HEX NYLOCK THIN SS		
25	86008130	73958	2	SPACER, 3/8OD X .62W X .312L, AL		
26	86274730	70265	2	SCR, 1/4-20 X 3/4 SHCS PLTD		
27	86070790	140737	2	BRKT, BATTERY LOCK MOUNT		
28	86087340	730339	2	SPACER, LATCH GUIDE		
29	86070800	140738	2	BRKT, BATTERY TRAY LOCK		
30	86271870	57290	2	NUT, 1/4-20 HEX NYLOCK THIN SS		
31	86276070	70593	1	SCR, 5/16-18 X 3/4 CARRIAGE SS		

BATTERY CART - OPTION

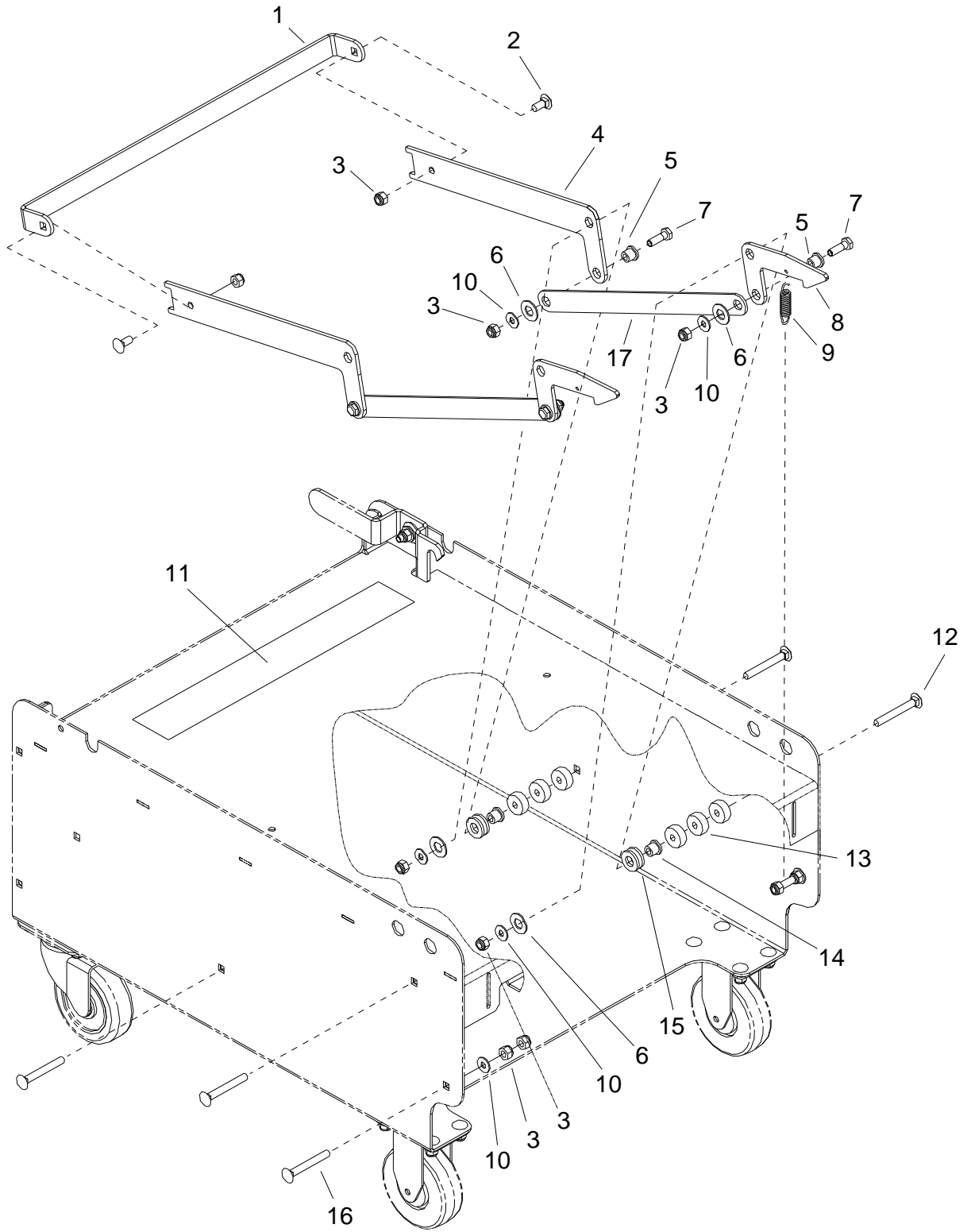

BATTERY CART - OPTION

REF	PART NO.	PRV NO.	QTY	DESCRIPTION	SERIAL NO. FROM	NOTES:
1	86078330	66478	1	PEDAL, BATTERY CART		
2	86276070	70593	2	SCR, 5/16-18 X 3/4 CARRIAGE SS		
3	86270830	57023	12	NUT, 5/16-18 HEX NYLOCK SS		
4	86087800	730307	2	STIFFENER, PEDAL, BATTERY CART		
5	86228840	09124	4	BEARING, FLANGED .314ID X .502OD		
6	86259410	87206	6	WASHER, THRUST .51 ID X 1 OD X .063		
7	86006560	70083	4	SCR, 5/16-18 X 1 HHCS SS		
8	86077140	51404	2	LATCH, BATTERY CART		
9	86226830	73268	2	SPRING, EXT .68D X 3.00L X .098W		
10	86010670	87029	10	WASHER, 5/16 FLAT SS		
11	86244280	500934	1	LABEL, BATTERY CART OPERATION		
12	86276060	70590	4	SCR, 5/16-18 X 2.5 CARR GR5		
13	86254280	730331	12	SPACER, 1.00 ODX .32ID X .375		
14	86231150	09151	4	BUSHING FLANGE, .314 X .502 OD		
15	86259400	87205	8	WASHER, THRUST .51 ID X 1 OD		
16	86276690	70715	16	SCR, 5/16-18 X 1.75 CARR SS		
17	86077530	51403	2	LINKAGE, LATCH, BATT CART		

SEAT - OPTION

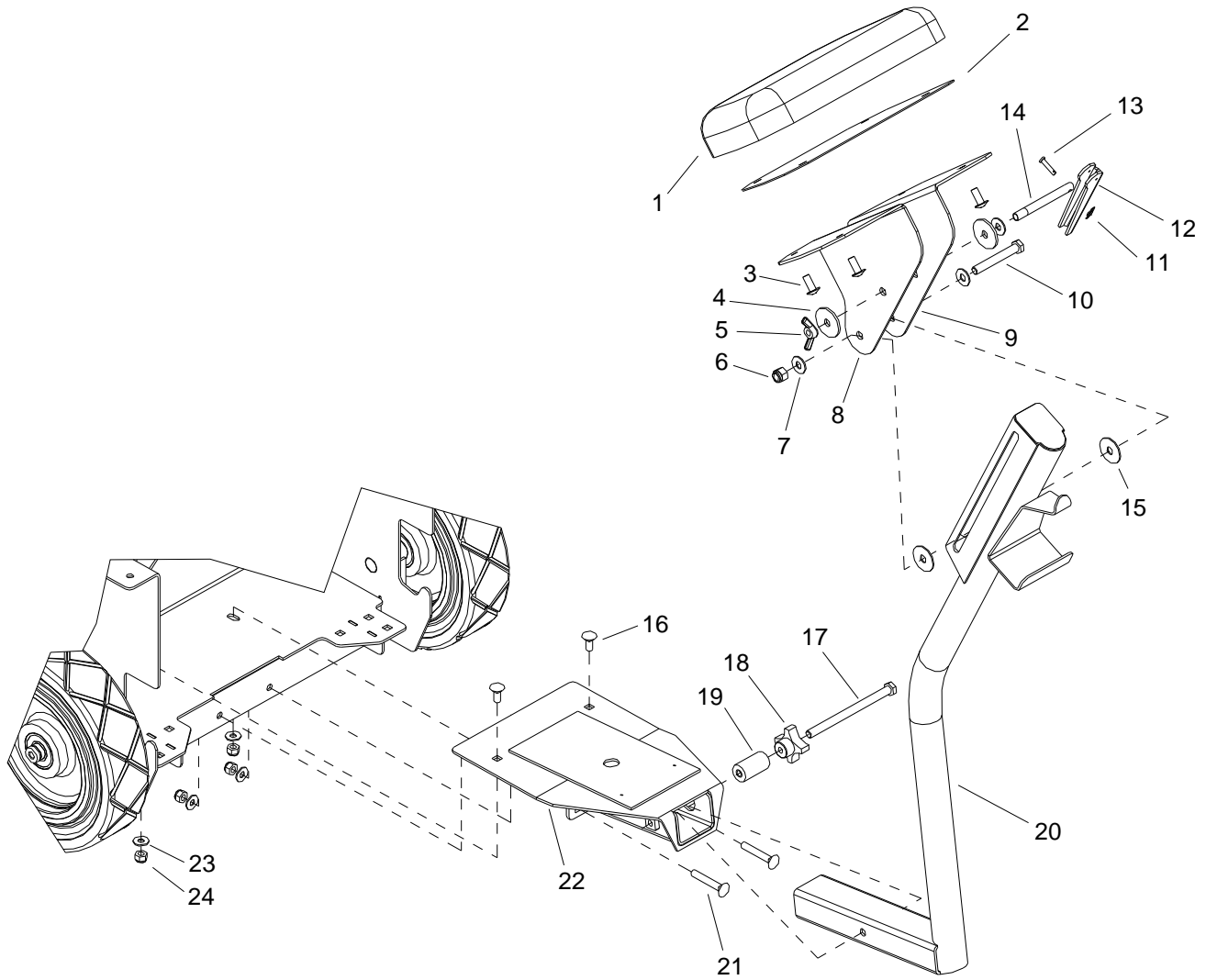

SEAT - OPTION

REF	PART NO.	PRV NO.	QTY	DESCRIPTION	SERIAL NO. FROM	NOTES:
1	86248390	730324	1	PAD, REAR REST		
2	86082640	629995	1	PLATE, SEAT COVER		
3	86276890	70752	4	SCR, 5/16-18 X 3/4 PTHMS SS		
4	86279460	87164	2	WASHER, 1/2 SPLIT LOCK		
5	86270710	01-000277	1	NUT, WING 3/8-16		
6	86271930	57297	1	NUT, 3/8-16 HEX NYLOCK SS		
7	86278910	87003	3	WASHR, 3/8 ID X 7/8 OD SS		
8	86070830	140742	1	BRKT, LEFT REAR SEAT		
9	86070840	140743	1	BRKT, RIGHT REAR SEAT		
10	86277710	730347	1	SCR, 3/8-16 X 2.75 HHCS SS		
11	86008650	80604	1	COTTER, 1/4" RING		
12	86246320	51142	1	LEVER, HANDLE LOCK		
13	86272300	66133	1	PIN, CLEVIS 3/16 X .88 PLTD		
14	86251860	66481	1	ROD, ARM HANDLE LOCK 4" LG		
15	86279620	87200	2	WASHER, .4ID X 1.3OD NYLON		
16	86276070	70593	2	SCR, 5/16-18 X 3/4 CARRIAGE SS		
17	86277510	70857	1	SCR, 3/8-16 X 5.0 HHCS SS FT		
18	86009200	81535	1	KNOB, 3/8-16 4 PRONG ALUM		
19	86254300	730350	1	SPACER, SEAT LOCK		
20	86094000	05246	1	SEAT MOUNT POST		
21	86276710	70717	2	SCR, 5/16-18 X 2.0 CARRIAGE SS		
22	86093790	05247	1	RECEIVER ASSY, SEAT MOUNT		
23	86010670	87029	4	WASHER, 5/16 FLAT SS		
24	86270830	57023	4	NUT, 5/16-18 HEX NYLOCK SS		

WARNING LIGHTS - OPTION

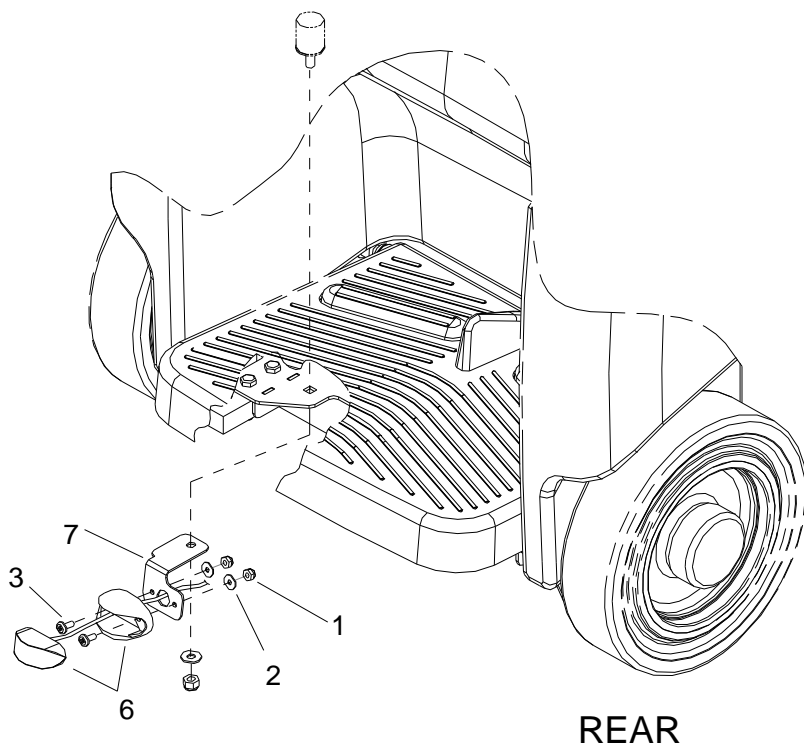
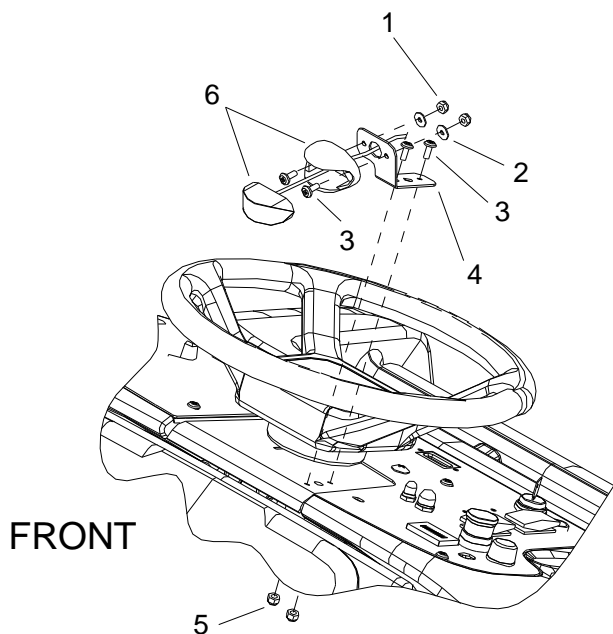

WARNING LIGHTS - OPTION

REF	PART NO.	PRV NO.	QTY	DESCRIPTION	SERIAL NO. FROM	NOTES:
1	86270990	57090	4	NUT, 10-32 HEX NYLOCK SS		
2	86010650	87018	4	WASHER, #10 X 6/16 OD		
3	86276820	70740	4	SCR, 10-32 X 1/2 PTHMS BLK		
4	86071490	140871	1	BRKT, UPPER WARNING LIGHT		
5	86270990	57090	2	NUT, 10-32 HEX NYLOCK SS		
6	86246200	51454	2	LED AMBER LIGHT, 12V		
7	86071500	140872	1	BRKT, LOWER WARNING LIGHT		



Manufacturers of Innovative Building Maintenance Equipment

Windsor Industries, Inc.
1351 West Stanford Avenue
Englewood, CO 80110 USA

Phone: 303.762.1800
FAX: 303.762.0817
<http://www.windsorind.com>

EC Declaration of Conformity

We herewith declare, Windsor Industries, Inc.
1351 W. Stanford Ave.
Englewood, CO 80110-5545 USA

that the following product complies with the appropriate essential health and safety requirements of the relevant EC Directives listed below, based on the relevant sections of the applicable EC standards and other normative documents.

Product: Chariot Scrubber Euro Deluxe 24

Product Identification: Rated 36 VDC 60 A

Trademark:



Model/Type Ref.: CSXE24

Product Description: This product is a battery powered, self-propelled, wet floor scrubber intended for commercial use.

Applicable EC Directives: EC Machinery Directive
(89/392/EEC & 91/368/EEC & 93/44/EEC & 93/68/EEC)
EC Low Voltage Directive
(73/23/EEC & 93/68/EEC)
EC Directive of Electromagnetic Compatibility
(89/336/EEC & 93/68/EEC)

Applicable Harmonized Standards: EN 60335-1: 1991
EN 60335-2-67: 1992
EN 60335-2-72: 1995
EN 55022: 1998-09
EN 55011: 1998-05
EN 61000-6-2: 1999
EN 61000-4-2: 1995
EN 61000-4-3: 1997

 4/18/05
Authorized Signature Date

Title of Signature: Vice President, Windsor Industries, Inc.

QUEST ...for Continuous Improvement.
Windsor's Quality Management System is Certified ISO 9001.



Manufacturers of Innovative Building Maintenance Equipment

Windsor Industries, Inc.
1351 West Stanford Avenue
Englewood, CO 80110 USA

Phone: 303.762.1800
FAX: 303.762.0817
<http://www.windsorind.com>

EC Declaration of Conformity

We herewith declare, Windsor Industries, Inc.
1351 W. Stanford Ave.
Englewood, CO 80110-5545 USA

that the following product complies with the appropriate essential health and safety requirements of the relevant EC Directives listed below, based on the relevant sections of the applicable EC standards and other normative documents.

Product: Chariot Scrubber Euro 24

Product Identification: Rated 36 VDC 60 A

Trademark:



Model/Type Ref.: CSE24

Product Description: This product is a battery powered, self-propelled, wet floor scrubber intended for commercial use.

Applicable EC Directives: EC Machinery Directive
(89/392/EEC & 91/368/EEC & 93/44/EEC & 93/68/EEC)
EC Low Voltage Directive
(73/23/EEC & 93/68/EEC)
EC Directive of Electromagnetic Compatibility
(89/336/EEC & 93/68/EEC)

Applicable Harmonized Standards: EN 60335-1: 1991
EN 60335-2-67: 1992
EN 60335-2-72: 1995
EN 55022: 1998-09
EN 55011: 1998-05
EN 61000-6-2: 1999
EN 61000-4-2: 1995
EN 61000-4-3: 1997

Authorized Signature

3/24/05
Date

Title of Signature: Vice President, Windsor Industries, Inc.

QUEST
...for Continuous Improvement.
Windsor's Quality Management System is Certified ISO 9001.



Manufacturers of Innovative Building Maintenance Equipment

Windsor Industries, Inc.
1351 West Stanford Avenue
Englewood, CO 80110 USA

Phone: 303.762.1800
FAX: 303.762.0817
<http://www.windsorind.com>

EC Declaration of Conformity

We herewith declare, Windsor Industries, Inc.
1351 W. Stanford Ave.
Englewood, CO 80110-5545 USA

that the following product complies with the appropriate essential health and safety requirements of the relevant EC Directives listed below, based on the relevant sections of the applicable EC standards and other normative documents.

Product: Chariot Scrubber Euro 24 Scrub Plus

Product Identification: Rated 36 VDC 60 A

Trademark:



Model/Type Ref.: CSE24SP

Product Description: This product is a battery powered, self-propelled, wet floor scrubber intended for commercial use.

Applicable EC Directives: EC Machinery Directive
(89/392/EEC & 91/368/EEC & 93/44/EEC & 93/68/EEC)
EC Low Voltage Directive
(73/23/EEC & 93/68/EEC)
EC Directive of Electromagnetic Compatibility
(89/336/EEC & 93/68/EEC)

Applicable Harmonized Standards: EN 60335-1: 1991
EN 60335-2-67: 1992
EN 60335-2-72: 1995
EN 55022: 1998-09
EN 55011: 1998-05
EN 61000-6-2: 1999
EN 61000-4-2: 1995
EN 61000-4-3: 1997

Authorized Signature

6-27-05
Date

Title of Signature: Vice President, Windsor Industries, Inc.



SERIAL NUMBERS

REF. NO.	MODEL: SERIAL #
1	CS24, CSE24, CSX24, CSXE24, CSXE024, CSE24SP, CS24SP : 1000170494
2	CS24, CSE24, CSX24, CSXE24, CSXE024, CSE24SP, CS24SP : 1000140332
3	CS24, CSE24, CSX24, CSXE24, CSXE024, CSE24SP, CS24SP : 1000143553
4	CS24, CSE24, CSX24, CSXE24, CSXE024, CSE24SP, CS24SP : 1000143906
5	CS24, CSE24, CSX24, CSXE24, CSXE024, CSE24SP, CS24SP : 1000144785
6	CS24, CSE24, CSX24, CSXE24, CSXE024, CSE24SP, CS24SP : 1000149450
7	CS24, CSE24, CSX24, CSXE24, CSXE024, CSE24SP, CS24SP : 1000149664
8	CS24, CSE24, CSX24, CSXE24, CSXE024, CSE24SP, CS24SP : 1000150256
9	CS24, CSE24, CSX24, CSXE24, CSXE024, CSE24SP, CS24SP : 1000150384
10	CS24, CSE24, CSX24, CSXE24, CSXE024, CSE24SP, CS24SP : 1000151588
11	CS24, CSE24, CSX24, CSXE24, CSXE024, CSE24SP, CS24SP : 1000154281
12	CS24, CSE24, CSX24, CSXE24, CSXE024, CSE24SP, CS24SP : 1000154660
13	CS24, CSE24, CSX24, CSXE24, CSXE024, CSE24SP, CS24SP : 1000155938
14	CS24, CSE24, CSX24, CSXE24, CSXE024, CSE24SP, CS24SP : 1000156273
15	CS24, CSE24, CSX24, CSXE24, CSXE024, CSE24SP, CS24SP : 1000157499
16	CS24, CSE24, CSX24, CSXE24, CSXE024, CSE24SP, CS24SP : 1000157501
17	CS24, CSE24, CSX24, CSXE24, CSXE024, CSE24SP, CS24SP : 1000157685
18	CS24, CSE24, CSX24, CSXE24, CSXE024, CSE24SP, CS24SP : 1000159164
19	CS24, CSE24, CSX24, CSXE24, CSXE024, CSE24SP, CS24SP : 1000159653
20	CS24, CSE24, CSX24, CSXE24, CSXE024, CSE24SP, CS24SP : 1000160355
21	CS24, CSE24, CSX24, CSXE24, CSXE024, CSE24SP, CS24SP : 1000168941
22	CS24, CSE24, CSX24, CSXE24, CSXE024, CSE24SP, CS24SP : 1000170203
23	CS24, CSE24, CSX24, CSXE24, CSXE024, CSE24SP, CS24SP : 10060140000046
24	CS24 : 10060210000104
25	CS24 : 10060210000143
26	CS24 : 10060210000178
27	CSE24 : 10060250000006
28	CSX24 : 10060270000498
29	CSXE24 : 10060290000001
30	CSXE024 : 10060300000001
31	CSE24: 10060250000007 , CSE24SP: 10060260000003 , CSXE024: 10060300000001 , CSX24: 10060270000736 , CSX24X: 10060280000078 , CS24: 1006021000252 , CS24SP: 10060220000080 , CS24SPX: 10060230000003 , CS24X 100602400000018
32	CSX24: 10060270000837 , CSXE24: 10060290000028 , CSXE024: 10060300000001
33	CSE24: 10060250000007 , CSXE024: 10060300000001 , CSX24: 10060270000837 , CSX24X: 10060280000085 , CS24: 1006021000317 , CS24X 100602400000024 , CSXE24 10060290000029
34	CS24: 10060210000315 , CSX24: 10060270000845 , CSXE024: 10030300000001 , CSE24: 10060250000007 , CSXE24: 10060290000029 , CS24SP: 10060220000091 , CSE24SP: 10060260000003