

3 – SPEED AIR MOVER

OWNERS MANUAL

IMPORTANT: READ OWNERS MANUAL CAREFULLY

Please fill out and return your warranty card!

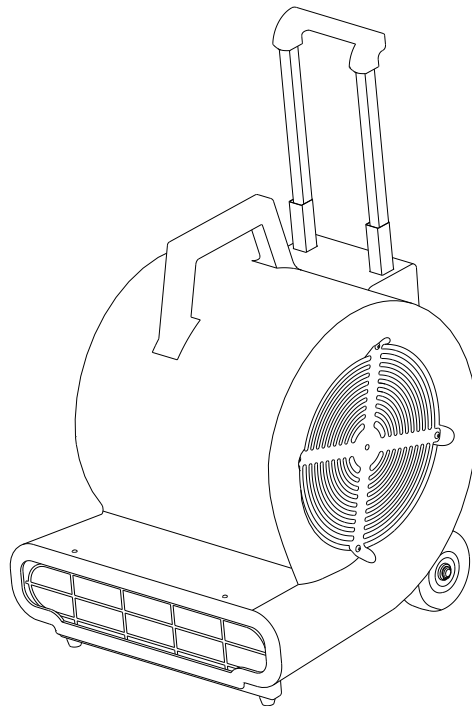

MODEL # STR3SPD.

REV 01 (6-12)

TABLE OF CONTENTS

Safety Precautions	3
Machine Operation	4
Machine Maintenance & Storage	4
Parts List	5-6
Wiring Diagram	7

SAFETY PRECAUTIONS

GROUNDING INSTRUCTIONS

General – This air mover shall be grounded while in use to protect the operator from electrical shock. The machine is provided with a three – conductor cord and a three – contact grounding type attachment plug to fit the proper grounding type receptacle. The green (or green & yellow) conductor in the cord is the grounding wire. Never connect this wire to anything other than the grounding pin of the attachment plug.

This machine is for use on a nominal 120 – volt circuit and has a grounding plug that resembles the plug illustrated in the figure below. Make sure that the machine is connected to an outlet having the same configuration as the plug. No adapter should be used with this machine.

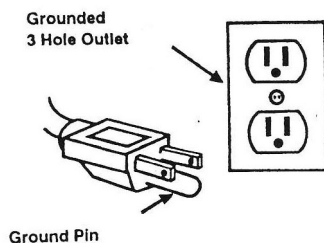

(120V)

This machine is intended for commercial use only. It is constructed for use in an indoor environment and is not intended for any other use.

All operators shall read, understand and exercise the following safety precautions:

- 1) Do not operate machine:
 - Unless trained and authorized.
 - Unless you have read and understand the operators manual.
 - In flammable or explosive areas.
 - With a damaged cord or plug.
 - If not in proper operating condition.
 - In outdoor areas.
 - In standing water.
 - With the use of extension cords.
- 2) Before operating machine:
 - Make sure all safety devices are in place and operate properly.
- 3) When using machine:
 - Do not pull machine by cord or plug.
 - Do not pull cord around sharp edges or corners.
 - Do not unplug machine by pulling on the cord.
 - Do not stretch cord.
 - Do not handle plug with wet hands.
 - Keep cord away from heated surfaces.
 - Report machine damage or faulty operation immediately.
- 4) Before leaving or servicing machine:
 - Turn off machine.
 - Unplug cord from outlet.
- 5) When servicing machine:
 - An experienced technician should only perform service work.
 - Unplug cord from outlet.
 - Use manufacturer supplied or approved replacement parts.

BASIC OPERATION

- 1) Check the machine for any obstructions in fan prior to operation.
 - If an item blocks the intakes of the air mover, this will hurt the performance of the machine, and could cause the motor to overheat.
- 2) Adjust machine to desired position for operation by pulling it back to it's preset height adjustments.
- 3) Plug power cord into a grounded outlet.
 - **Do not use an extension cord in conjunction with the standard power cord.**
- 4) This machine has 3 power settings. Turn the power knob to the desired speed. Low = 1, Med = 2, High = 3.
- 5) To stop the machine at any time, simply turn the power knob to the "off" position.
 - **Never stick any object into the air inlet vents or the air outlet vent.**

MAINTENANCE

To keep this machine performing well for many years, please follow the following maintenance procedures:

- **Always confirm the machine is unplugged from the power source prior to performing any maintenance or repairs!**
- 1) Unplug machine as soon as you are done using it.
 - 2) Wrap the power cord around the carrying handle.
 - 3) Check power cord for any damage. If any damage is detected, replace the cord immediately.
 - 4) Lubricate the handle assembly and wheels with a water resistant lubricant every month.
 - 5) Check machine for loose or missing nuts and bolts, and replace as necessary.
 - 6) Clean the outside of the machine with a mild cleaner.

STORAGE

- 1) Unplug machine from power source.
- 2) Store in upright position in a dry area.

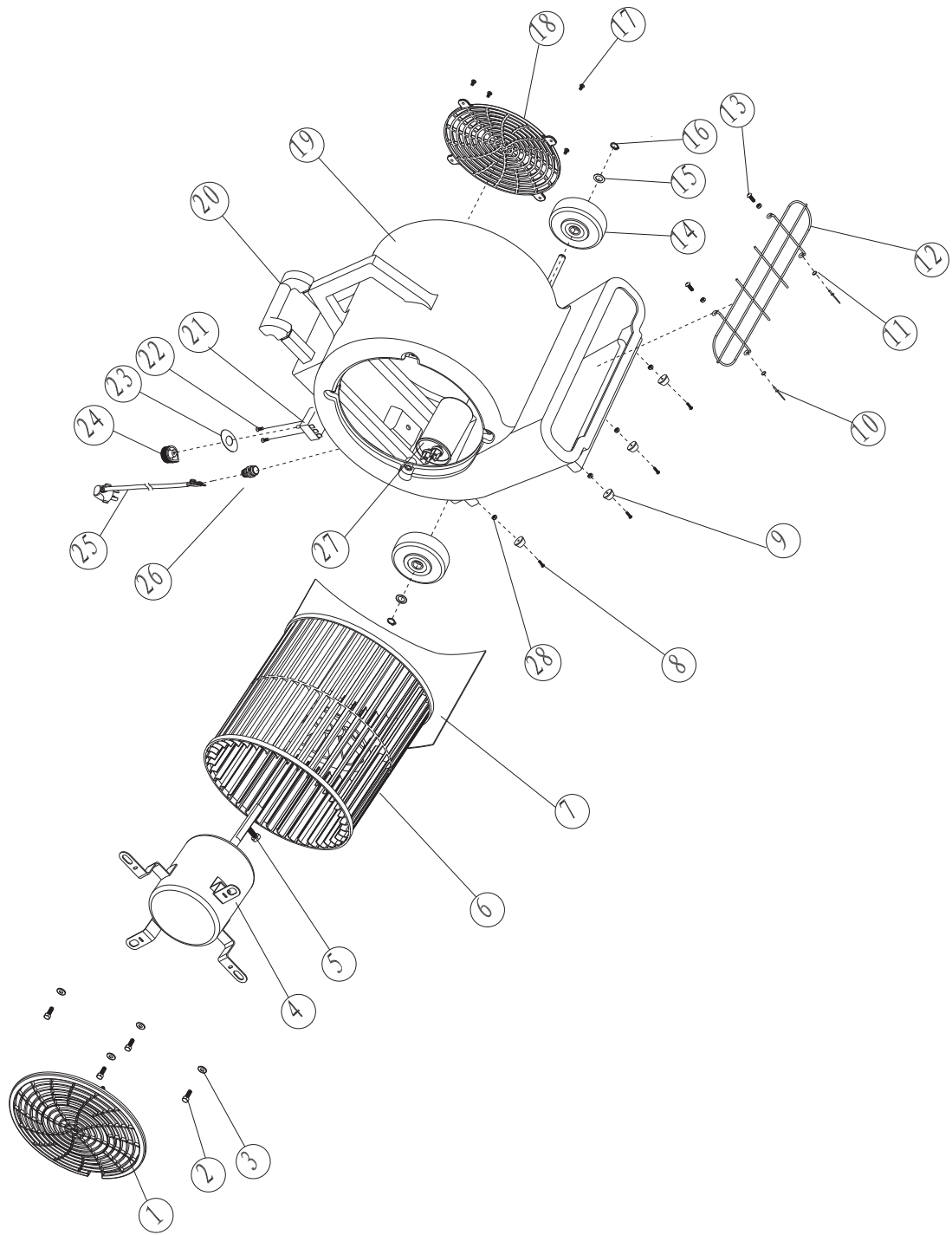

BASE ASSEMBLY - AIR MOVER			
DIAGRAM NUMBER	PART NUMBER	DESCRIPTION	NUMBER REQUIRED
1	BF534-1	INTAKE, VENT, LEFT	1
2	BF534-2	SCREW, M6 X 20MM	6
3	BF534-3	WASHER, 1.5MM	4
4	BF534-4	MOTOR, 120V / 60HZ	1
5	BF534-5	SCREW, M8 X 20MM	1
6	BF534-6	FAN WHEEL	1
7	BF534-7	AIR BAFFLE	1
8	BF534-8	SCREW, M5 X 16	6
9	BF534-9	FOOT	4
10	BF534-10	SCREW, M4 X 25MM	5
11	BF534-11	WASHER, 1.5MM	5
12	BF534-12	OUTLET VENT, FRONT	1
13	BF534-13	SCREW, M5 X 15	2
14	BF534-14	WHEEL, 38MM, RUBBER	2
15	BF534-15	WASHER, 1.5MM	2
16	BF534-16	RETAINER	2
17	BF534-17	SCREW, M4 X 12MM	4
18	BF534-18	INTAKE, VENT, RIGHT	1
19	BF534-19	HOUSING	1
20	BF534-20	HANDLE ASSEMBLY	1
21	BF534-21	SWITCH ASSEMBLY	1
22	BF534-22	SCREW, M4 X 12MM	2
23	BF534-23	LABEL, SPEED INDICATOR	1
24	BF534-24	KNOB, SWITCH	1
25	BF534-25	POWER CABLE	1
26	BF534-26	CABLE CLAMP	1
27	BF534-27	CAPACITOR	1

WIRING DIAGRAM

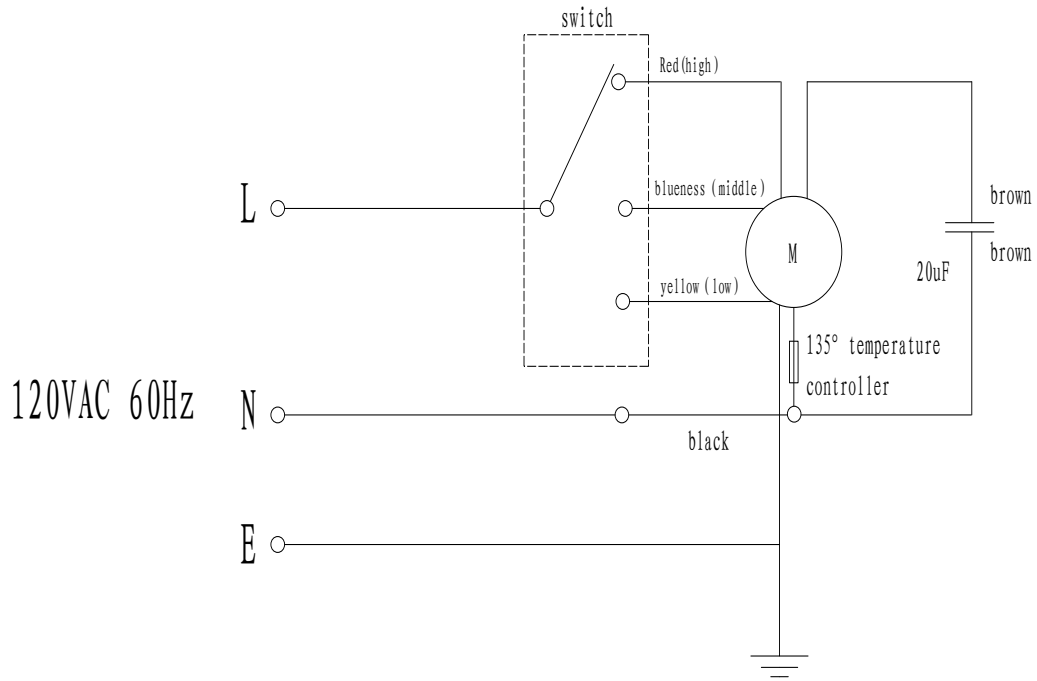

BF533/534/535 (ETL)

