



www.usviper.com

BARRACUDA DUAL MOTOR VACUUM

OWNERS MANUAL

IMPORTANT: READ OWNERS MANUAL CAREFULLY
Please fill out & return your warranty card!

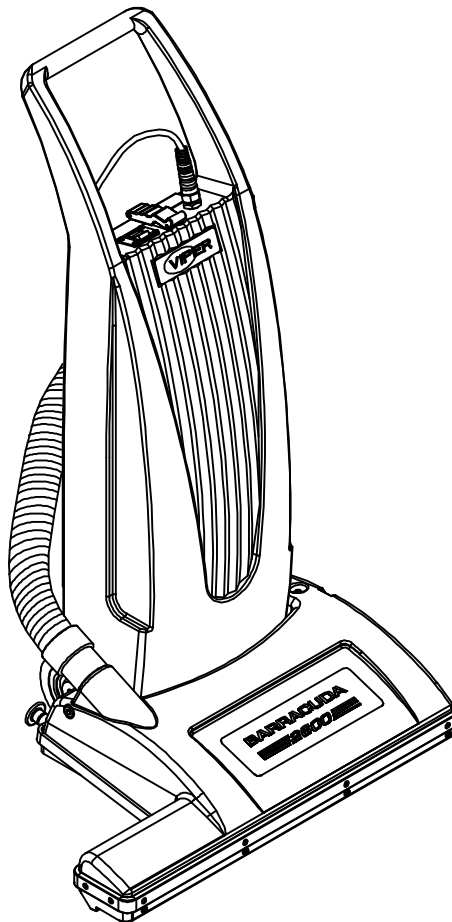

MODEL# CUDA26

SERIAL#

VIPER ...exceptional
value

REV.03(14-09)
VA51063



TABLE OF CONTENTS

Safety Precautions	1
Machine Components	2
Machine Operation	3-4
Machine Maintenance & Storage	4
Troubleshooting	5
Parts Breakdown	6
Parts Lists	7-8
Accessories	9
Wiring Diagram	10



SAFETY PRECAUTIONS

GROUNDING INSTRUCTIONS

General – This carpet vacuum shall be grounded while in use to protect the operator from electric shock. The machine is provided with a three-contact grounding type attachment plug to fit the proper grounding type receptacle. The green (or green & yellow) conductor in the cord is the grounding wire. Never connect this wire to other than the grounding pin of the attachment plug.

This machine is for use on a nominal 120-volt circuit and has a grounding plug that resembles the plug illustrated in figure below. Make sure that the machine is connected to an outlet having the same configuration as the plug. No adapter should be used with this machine.

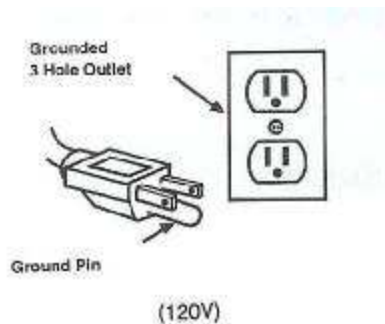

This machine is intended for commercial use. It is constructed for use in an indoor environment and is not intended for any other use. Use only recommended accessories.

All operators shall read, understand and exercise the following safety precautions:

- 1) Do not operate machine:
 - Unless trained and authorized
 - Unless you have read and understand operators manual
 - In flammable or explosive areas.
 - With damaged or modified cord or plug.
 - If not in proper operating condition.
 - In outdoor areas.
 - In standing water.
 - Without bag / filters in place.
 - With the use of unapproved extension cords.
- 2) Before operating machine:
 - Make sure all safety devices are in place and operate properly.
- 3) When using machine:
 - Do not run machine over cord.
 - Do not pull machine by cord or plug.
 - Do not pull cord around sharp edges or corners.
 - Do not unplug by pulling on the cord.
 - Do not stretch cord.
 - Do not handle plug with wet hands.
 - Keep cord away from heated surfaces.
 - Do not pick up flammable materials or reactive metals.
 - Report machine damage or faulty operation immediately.
 - Do not allow children to operate machine.
- 4) Before leaving or servicing machine:
 - Turn off machine.
 - Unplug power cord from outlet.
- 5) When servicing machine:
 - Unplug cord from outlet.
 - Use manufacturer supplied or approved replacement parts.
 - Avoid moving parts. Do not wear loose clothing.

MACHINE COMPONENTS

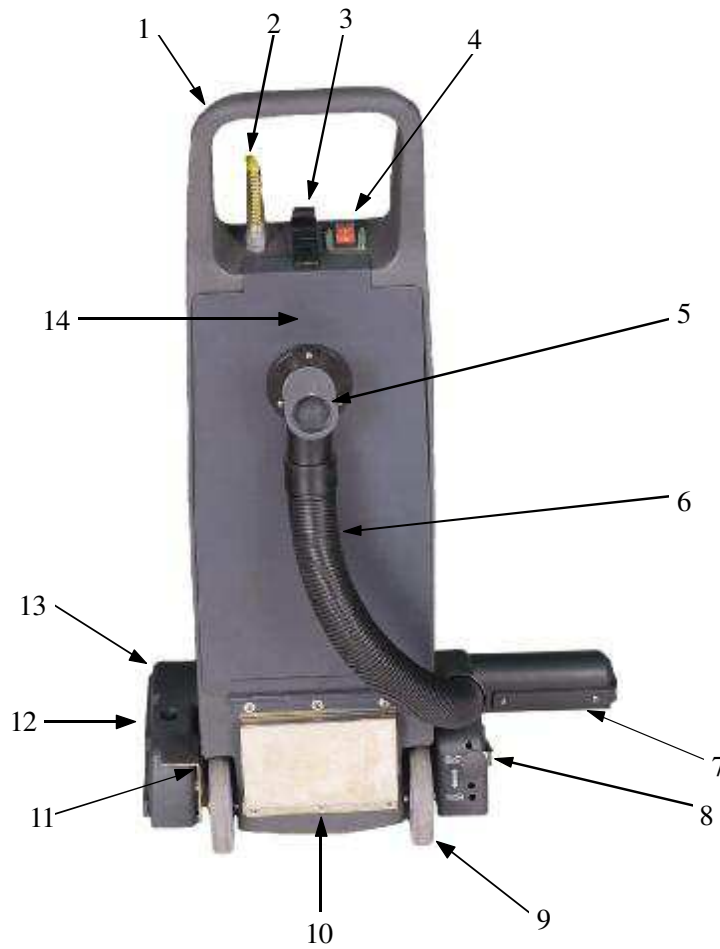

- 1) Handle
- 2) Power cord
- 3) Door latch
- 4) Power switch
- 5) Attachment tool intake & cord wrap
- 6) Vacuum hose
- 7) Brush housing
- 8) Brush height adjustment
- 9) Rear wheels
- 10) Exhaust vent
- 11) Handle height adjustment
- 12) Brush circuit breaker (bottom side)
- 13) Brush assembly (bottom side)
- 14) Rear door

MACHINE OPERATION

PRIOR TO VACUUMING CARPETS

- 1) Inspect power cable and extension cable for damage. Replace cable if damage is found.
- 2) Ensure filter bag is properly installed
NOTE: Never operate machine without filter bag installed. This could cause damage to the vacuum motor.
- 3) Set proper height adjustment for carpet being cleaned.

CARPET VACUUMING

- 1) Depress foot pedal and lower vacuum head to floor.
- 2) Turn on power switch.



- 3) Operate by using standard vacuuming procedures.
- 4) Check bag periodically to see if it is full. Replace if necessary.
- 5) To clean under desks or other tight areas, depress the foot pedal an additional time to lower the handle even further.

OPERATING HINTS

- 1) Overlap cleaning path by approx. 2 inches
- 2) Work away from power outlet and power cable in order to avoid damage to the power cable.

- 3) Occasionally check the bag for fullness & replace as necessary.
- 4) If brush stops spinning, there may be an obstruction in the brush. Unplug the power cable, raise the brush off the floor and check for an obstruction. Check & reset the brush circuit breaker located on the bottom of the brush housing.

USE OF ACCESSORY TOOLS

NOTE: Accessory tools are available as an option. Kit VA51061 includes: Dusting brush, crevice tool, upholstery tool, 8' vacuum hose, etc.

- 1) Machine must be in upright position whenever using attachment tools.
- 2) Remove vacuum hose on the vacuum intake port on rear of machine.
- 3) Connect (optional) 8' vacuum hoses to intake port & connect desired accessory tool to end of hose.
- 4) Turn on vacuum switch and operate tool using normal vacuuming procedures.



VACUUM BAG INSTALLATION & REMOVAL

- 1) Unlock rear door latch, and allow door to hinge open.
- 2) Place paper bag / filter into tank opening.
- 3) On paper bag / filter, slide rubber vacuum collar onto vacuum intake spout.
- 4) Close rear door and lock into place.
NOTE: Be sure the bag / filter is properly placed in bag housing to ensure proper air flow.
- 5) To remove bag, simply reverse steps 1-4 above.
- 6) Do not re-use paper bag / filter. When full, dispose of it and replace with a new one.
- 5) Check paper bag / filter for fullness. If it is full, replace with a new one.
- 6) Check vacuum motor filter and exhaust filter for debris and clean as needed.
NOTE: Do not clean filters with water or a cleaning solution. Clean by tapping of debris or blowing with air.
- 7) Inspect brush for strands of carpet and debris and remove as needed.
- 8) Inspect brush bristles for wear and damage. Replace brush as needed.
- 9) Inspect gaskets and seals for air leaks and replace as needed.
- 10) Check vacuum hose for clogs and holes and replace as needed.
- 11) Check vacuum motor carbon brushes every 250 hours. Replace brushes when they are 3/8" or less in length.
NOTE: Vacuum motor damage caused by worn brushes is not covered by warranty.

MACHINE MAINTENANCE

To keep the machine performing well for many years, please follow the following maintenance procedures.

!!! Always confirm that the machine is unplugged prior to performing any maintenance or repairs!!!

- 1) Unplug machine as soon as you are done using it.
NOTE: When unplugging machine, do not pull cord around sharp edges or corners & do not unplug by pulling on the cord.
- 2) Clean outside of machine with a mild cleaner.
- 3) Check power cord for any damage. If any damage is detected, replace the cord immediately.
- 4) Check machine for any loose or missing nuts and bolts and replace as necessary.

MACHINE STORAGE

- 1) Prior to storing the machine, wrap up power cord, check paper bag / filter for fullness and replace if necessary.
- 2) Clean and / or replace filters.
- 3) Store machine in upright position in a dry area, with the brush head off the floor.

BASIC TROUBLESHOOTING

PROBLEM	CAUSE	SOLUTION
Machine does not work	Power switch not in "on" position	Turn power switch "on"
	Power cord not plugged into outlet	Plug power cord into outlet
	Power cord is faulty	Replace with approved power cord
	Building circuit breaker tripped	Reset circuit breaker
	Faulty wiring	Contact Viper Distributor
	Faulty on / off switch	Contact Viper Distributor
Brush does not work	Brush circuit breaker tripped	Check brush and belt for obstructions and remove as needed
		Reset circuit breaker
Poor brush pickup	Incorrect brush height adjustment	Adjust brush height
	Clogged brush	Remove debris from brush
	Brush is worn	Contact Viper Distributor
	Loose brush drive belt	Inspect belt and replace as needed
Low suction	Vacuum hose clogged	Remove vacuum hose and check for obstructions
	Vacuum hose faulty	Check vacuum hose for loose cuffs or holes and replace as needed
	Filters clogged	Remove vacuum filter and exhaust filter and clean
	Vacuum bag full	Check vacuum bag / filter and relplace as needed

PARTS LIST

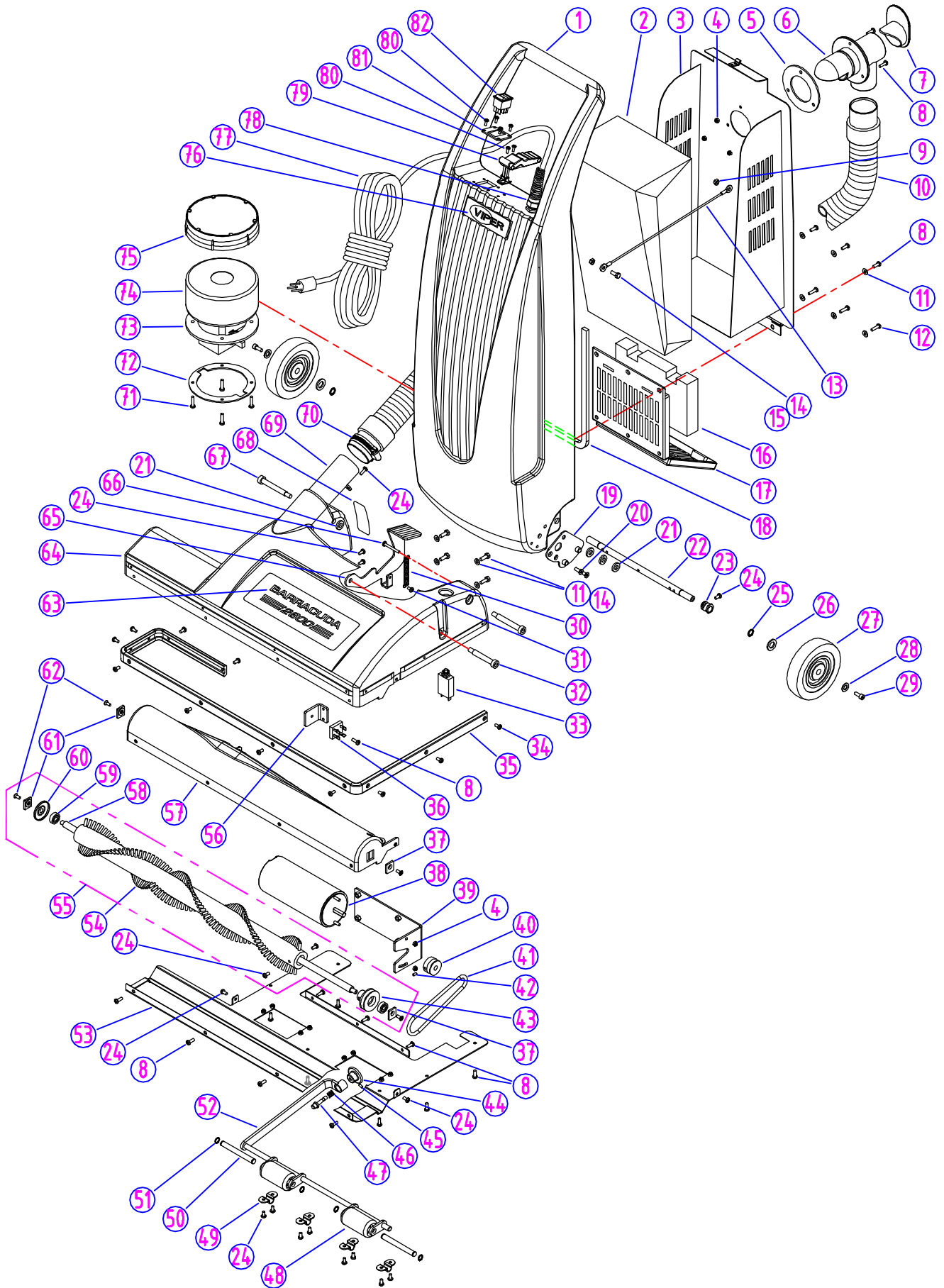

PARTS LIST

DIA NO	PART NUMBER	DESCRIPTION	NO REQ'D
1	VA51009	HANDLE HOUSING	1
2	VA51025	PAPER BAG, DUST, 10.5qt.	1
	VA51067	CLOTH BAG, DUST(OPTIONAL)	
3	VA51007	REAR COVER AND BAG HOLDER	1
4	GT13022	NUT, M5, NYLON INSERT	5
5	VA51034	GASKET, ADAPTER	1
6	VA51008	ELBOW ADAPTER, HOSE	1
7	VA51022	PLUG AND CORD HOOK	1
8	VV20501	SCREW, M5x14	20
9	VA13489	NUT, ACORN, M6	1
10	VA51023	HOSE, 2"	1
11	VF13533	WASHER, PLAIN, ϕ 6	10
12	VV13635	SCREW, M5x20	3
13	VF82028	WIRE ROPE, STAY, REAR COVER	1
14	VF13495	SCREW, HEX, M6x16	5
15	VF13502	NUT, M6, NYLON INSERT	1
16	VA51065	FILTER, EXHAUST	1
17	VA51064	HOUSING, EXHAUST FILTER	1
18	VA51050	GASKET, HANDLE HOUSING, 8x13mm, SBR	1
19	VA51073	LATCH PLATE	1
20	VV13605	SCREW, FLAT, M6x16	2
21	VA51041	NYLON WASHER	4
22	VA51027	AXLE	1
23	VA51059	ECCENTRIC BUSHING	2
24	VV20509	SCREW, M5x10	17
25	VF13520	RETAINING RING, EXTERNAL, ϕ 12	2
26	VF13538	WASHER, PLAIN, ϕ 12x ϕ 24x2	2
27	VF48202	WHEEL, 5"	2
28	VF13666	WASHER, PLAIN, ϕ 12	2
29	VF44012	SCREW, M5x12.7	2
30	VA51038	SPRING, LATCH	1
31	VF14214	SCREW, M5x8	1
32	VA51039	SHOULDER BOLT, LATCH	1
33	VV67504	CIRCUIT BREAKER, 2AMP	1
34	GT13057	SCREW, SELF-TAPPING, ST5x10	14
35	VA51002	BUMPER, 26"	1
36	VF99926-1	RECTIFIER	1
37	VA51066	BLOCK, BRUSH SHAFT, LEFT	1
38	ZD57000	MOTOR, BRUSH, 115V	1
39	VA51011	MOUNT PLATE, MOTOR	1
40	VA51019	PULLEY, MOTOR	1

PARTS LIST

DIA NO	PART NUMBER	DESCRIPTION	NO REQ'D
41	VA51021	DRIVE BELT	1
42	VF14254	SCREW, HOLDING, M5x8	1
43	VA51018	PULLEY, BRUSH	1
44	VA51035	KNOB, ROLLER ADJUST	1
45	VF13508	SCREW, HOLDING, M4x8	1
46	VA51037	SPRING, ROLLER ADJUST	1
47	VA51036	LOCK PIN, ROLLER ADJUST	1
48	VA51042	ROLLER, 1.5"	2
49	VA51013	CLAMP, ROLLER BRACKET	4
50	VA51043	AXLE, ROLLER	2
51	VA14001	RETAINING RING, EXTERNAL, ϕ 10	4
52	VA51014	ROLLER BRACKET	1
53	VA51004	BOTTOM SHOE PLATE, 26"	1
54	VA51005	BRUSH, 26"	1
55	VA51005A	BRUSH, ASSEMBLY, 26"	1
56	VA51047	BRACKET, RECTIFIER	1
57	VA51003	BRUSH HOUSING, 26"	1
58	VA51006	SHAFT, BRUSH, 26"	1
59	VA51015	BEARING	2
60	VA51017	STRING GUARD, BRUSH	1
61	VA51016	BLOCK, BRUSH SHAFT, RIGHT	1
62	VV20502	SCREW, FLAT, M5x16	2
63	VA51048	LABEL, "BARRACUDA"	1
64	VA51001	BASE HOUSING, 26"	1
65	VA51071	LATCH, HANDLE	1
66	VA13476	SCREW, M5x40	1
67	VA51040	SHOULDER BOLT, PIVOT	2
68	VA51052	LABEL	1
69	VA51012	TUBE, BASE HOUSING	1
70	VV10120	CLAMP	1
71	GT13070	SCREW, SELF-TAPPING, ST4.8x25	4
72	VA51032	RETAINER RING, VACUUM MOTOR	1
73	VA51033	GASKET, VACUUM MOTOR	1
74	ZD52000A	VACUUM MOTOR, 115V	1
75	VA51049	FILTER, VACUUM MOTOR	1
76	VF82082	LOGO, "VIPER"	1
77	VA65001	POWER CORD, 14/3C, SJTW, 50FT	1
78	VA51044	STRAIN RELIEF, CORD	1
79	VF83109	CATCH	1
80	VV13650	SCREW, M4x10	6
81	VA51026	PLATE, SWITCH	1
82	VF91346	SWITCH, ROCKER	1

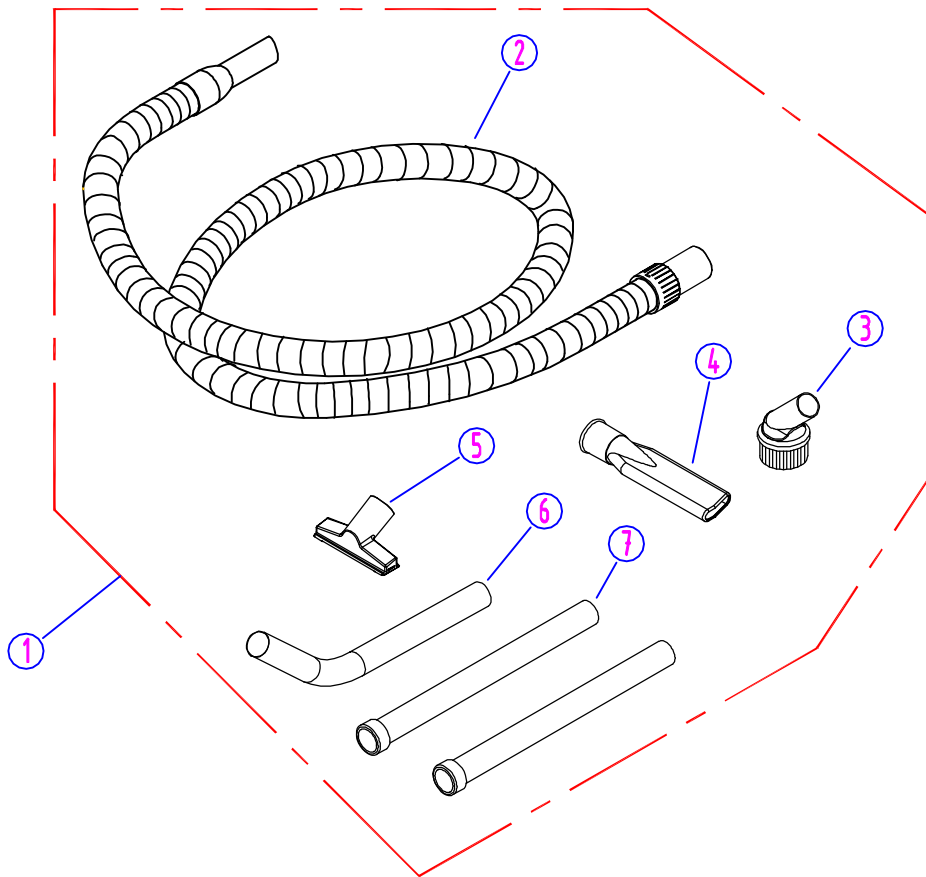

ACCESSORIES PARTS LIST(OPTIONAL)

DIA NO	PART NUMBER	DESCRIPTION	NO REQ'D
1	VA51061	KIT TOOLS (OPTIONAL)	1
2	VA51060	HOSE ASSY	1
3	VA20803	DUSTING TOOL	1
4	VA20806	CREVICE TOOL	1
5	VA20807	UPHOLSTERY TOOL	1
6	VA20209	WAND	1
7	VA20248	TUBE	2

Wiring Diagram

CUDA26

