

LOW SPEED FLOOR MACHINES

OWNERS MANUAL

IMPORTANT: READ OWNERS MANUAL CAREFULLY
Please fill out & return your warranty card !

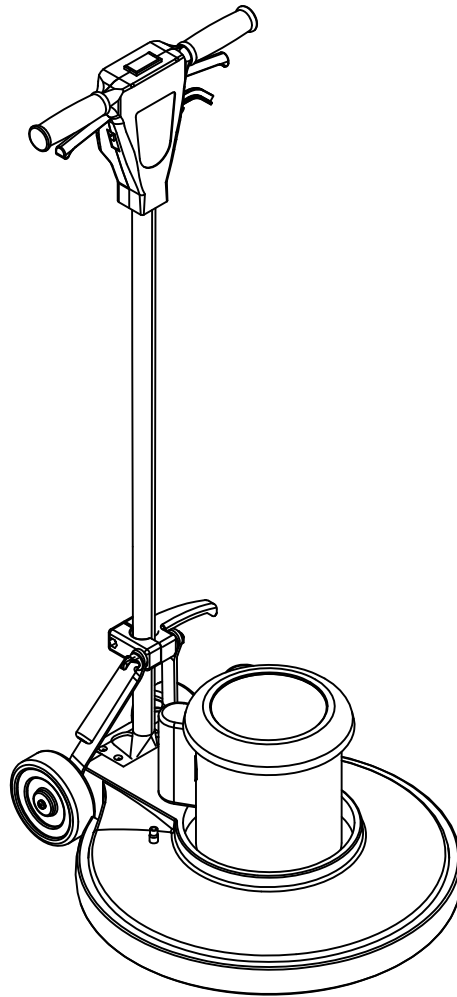

MODEL #

TP2015HD

REV.01(12-07)

41055TP

TABLE OF CONTENTS

Safety Precautions	3
Machine Operation	4
Machine Maintenance & Storage	4
Handle Release Assembly Instructions	5
Parts List	6--9
Wiring Diagram	10

SAFETY PRECAUTIONS

GROUNDING INSTRUCTIONS

This floor machine shall be grounded while in use to protect the operator from electric shock. The machine is provided with a three-conductor cord and a three contact grounding type attachment plug to fit the proper grounding type receptacle. The green [or green and yellow] conductor in the cord is the grounding wire. Never connect this wire to anything other than the grounding pin of the attachment plug.

This machine is for use on a nominal 120-Volt circuit and has a grounding plug that resembles the plug illustrated in figure below. Make sure that the machine is connected to an outlet having the same configuration as the plug. No adapter should be used with this machine.

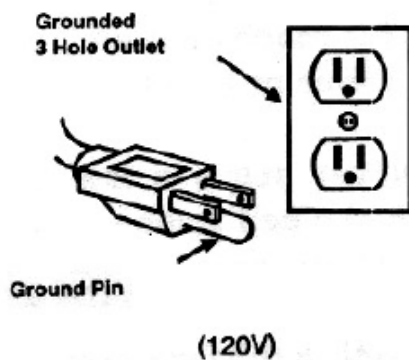

This machine is intended for commercial use. It is constructed for use in an indoor environment and is not intended for any other use. Use only with recommended accessories.

All operators shall read, understand and exercise the following safety precautions:

- 1] Do not operate machine:
 - Unless trained and authorized.
 - Unless you have read and understand operators manual.
 - In flammable or explosive areas.
 - With a damaged cord or plug.
 - If not in proper operating condition.
 - In outdoor areas.
 - In standing water.
 - With the use of extension cords.
- 2] Before operating machine:
 - Make sure all safety devices are in place and operate properly.
- 3] When using machine:
 - Do not run machine over cord.
 - Do not pull machine by cord or plug.
 - Do not pull cord around sharp edges or corners.
 - Do not unplug by pulling on the cord.
 - Do not stretch cord.
 - Do not handle plug with wet hands.
 - Keep cord away from heated surfaces.
 - Report machine damage or faulty operation immediately.
- 4] Before leaving or servicing machine:
 - Turn off machine.
 - Unplug cord from outlet.
- 5] When servicing machine:
 - Unplug cord from outlet.
 - Use manufacturer supplied or approved replacements parts.

Operation of Floor Machine

- * Read operators manual thoroughly prior to operating or servicing this machine.

GENERAL USE

- 1] Remove any obstructions or other obstacles in the area which is to be cleaned.
- 2] Place the handle in the upright position and tilt machine back until handle rests on the floor.

- **Be sure the machine is not plugged into an outlet.**

- 3] Attach the pad driver or brush to the machine by placing the clutch plate over the gearbox hub and turning the driver / brush 1/4 turn.
- 4] Place machine back into its upright position.
- 5] Plug power cord into grounded outlet.

* Never use an extension cord in conjunction with the standard power cord.

- 6] The handle height may be adjusted by lifting up the compression handle which is located on the right side of the handle tube about 1 foot above floor level. Release the compression handle and adjust handle to safe operating height, then push back down on the compression handle to lock the handle in operating position.
- 7] To start the machine, press the red safety button on the top of the upper switch housing, and then squeeze either of the operating triggers. [the safety button must be depressed prior to squeezing the operating triggers].
- 8] When the machine is in operation, both hands should be placed on the switch housing [upper handle].
- 9] During operation, to make the machine go right, gently raise the handle. To make the machine to left, gently lower the handle.

- 10] To stop the machine at any time, simply release the operating trigger [s] and the machine will stop automatically.

MAINTENANCE

To keep the machine performing well for many years, please follow the following maintenance procedures.

*** Always confirm that the machine is unplugged prior to performing any maintenance or repairs.**

- 1] Unplug machine as soon as you are done using it.
- 2] Tilt machine back and remove pad driver or brush.

***Never store a low speed machine with the pad driver or brush mounted to the machine**

- 3] Clean the outside of the machine with a mild cleaner.
- 4] Check power cord for any damage. If damage is detected, replace the cord immediately.
- 5] Lubricate wheels with a water resistant lubricant once a month.
- 6] Check machine for loose or missing nuts and bolts, and replace as necessary.
- 7] If the machine is used in a dusty environment, you may remove the motor cover and blow the motor clean with compressed air. This will ensure proper ventilation, and allow the motor to run cooler.

STORAGE

- 1] Unplug machine from power source and wrap cord on handle.
- 2] Tilt machine back and remove pad driver or brush.
- 3] Store machine in upright position and in a dry area.

Handle Release Assembly Instructions

STEP #3

- 1) Place cord wrap assembly (2 pieces) in place, and snug them together with 6mm hex bolt. (actual cord wrap faces to the left of the machine when you are standing behind it)
- 2) Assemble hardware in the following order: spacer, left handle bracket, nylock nut. (do not over tighten nylock nut, Only tighten it enough to hold handle in place when compression lever is in down position)

STEP #4

- 1) Connect power cords together.
- 2) Connect power cord covers together.

STEP #2

- 1) Remove handle clamp blocks with 5mm hex head
- 2) Place handle assembly into handle clamp blocks
- 3) Re-attach the blocks to the base with 5mm hex head

STEP #1

- 1) Remove nut and spacer from handle bracket assembly.
- 2) Push the two handle brackets forward so they lean against the motor.

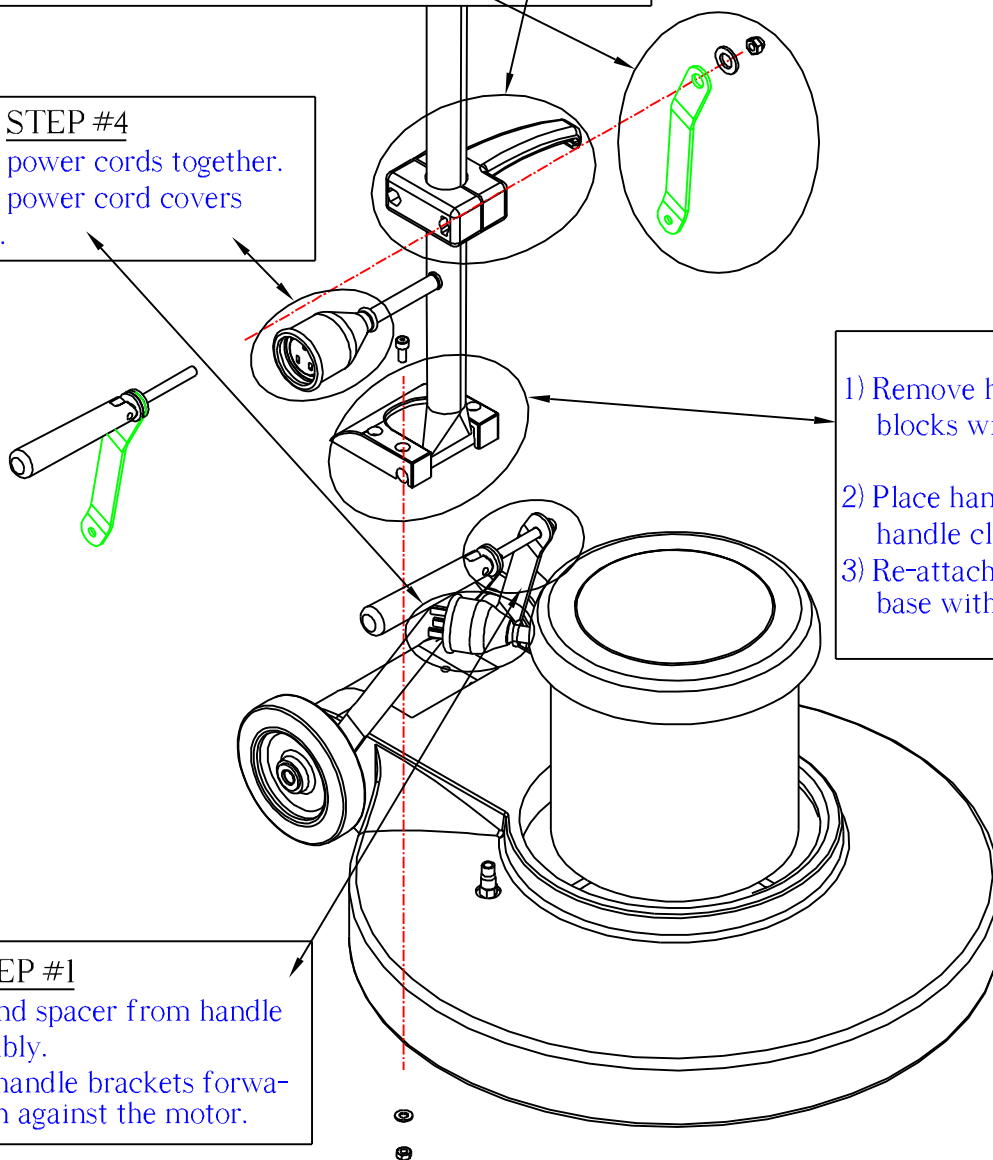

HANDLE ASSEMBLY

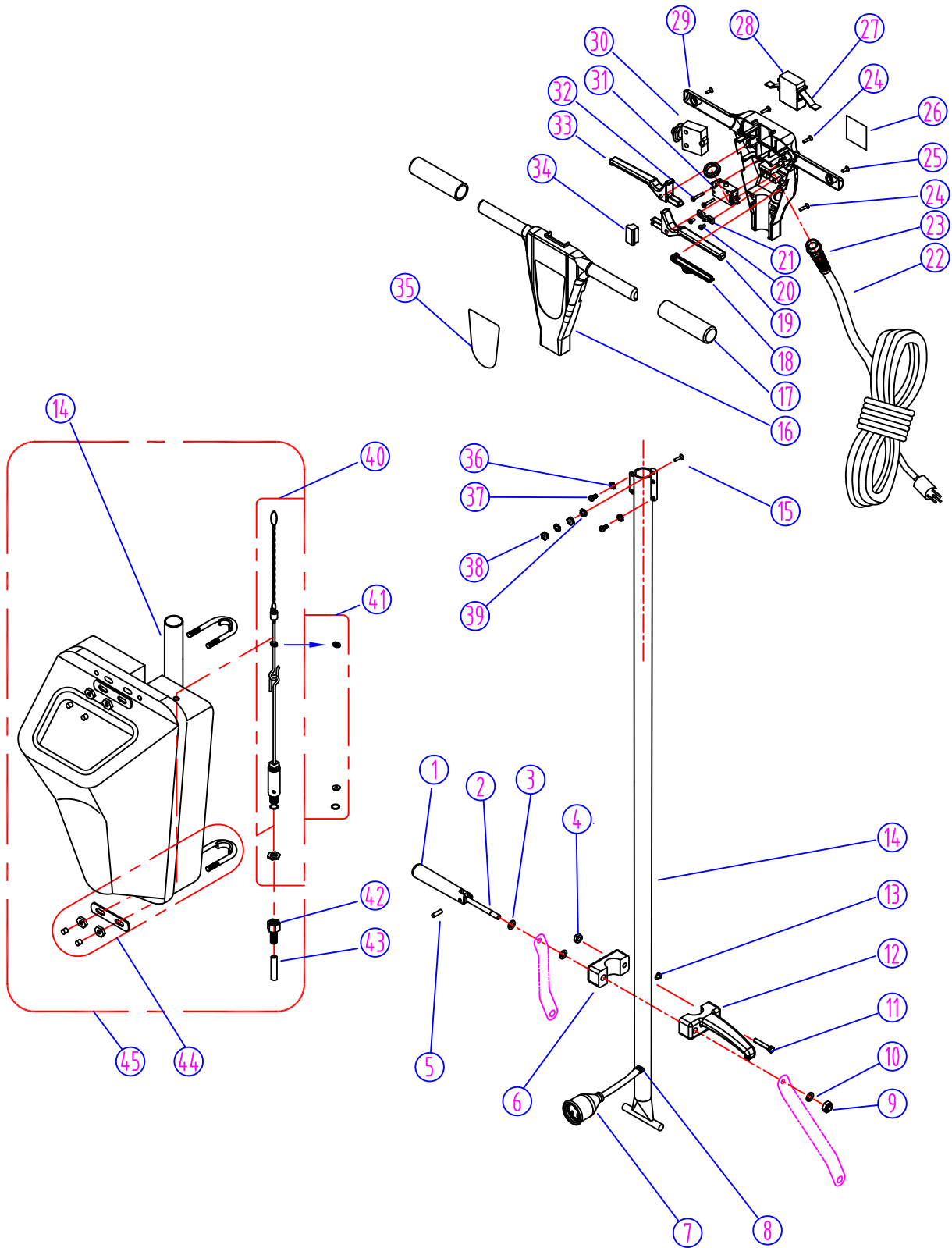

HANDLE ASSEMBLY

DIA NO	PART NUMBER	DESCRIPTION	NO REQ'D
1	VF30016	HANDLE RELEASE	1
2	VF30015	BOLT, HANDLE RELEASE	1
3	VF30018	WASHER, PLAIN	2
4	VF13503	NUT, LOCK, M8 X 5.7	1
5	VF30017	SCREW	1
6	VF30014	COVER, HOOK	1
7	VF45125	CORD, HANDLE	1
	AS41901	PLUG PROTECTOR, SMALL MALE	1
8	VF50120	GROMMET	1
9	VF13504	NUT, LOCK, M10	1
10	VF13517	WASHER, PLAIN	1
11	VF14114	SCREW, M8 X 55	1
12	VF30013	HOOK	1
13	VF13493	SCREW, M6 X 10	1
14	AS312206	TUBE	1
15	AS22002	SCREW, M5 X 16	1
16	AS312209	FRONT COVER	1
17	VF48310	HANDLE GRIP	2
18	AS22006S	LEVER, SOLUTION	1
19	AS22004S	LEVER, LEFT, SWITCH	1
20	VV13661	SCREW, M4 X 12	2
21	VF48309	CLAMP BLOCK	1
22	VF45119	CORD, POWER SUPPLY	1
23	AS22009	STRAIN RELIEF, CORD	1
24	GT13009	SCREW, M5 X 30	5
25	GT13008	SCREW, M5 X 20	2
26	VF41004TP	SERIAL TAG	1
27	GV40218	SAFETY BUTTON	1
28	GV40209	SAFETY BUTTON	1
29	AS312209	REAR COVER	1
30	VF99010C	BREAKER, CIRCUIT, 17A	1
31	VF99023	SWITCH ASSY	1
32	VF14212	SCREW, M3 X 25	2
33	AS22005S	LEVER, RIGHT, SWITCH	1
34	AS312203	COVER	1
35	GV40226B	LABEL, FRONT COVER	1
36	VF13604	TOOTH WASHER, M5	4
37	VF14222	SCREW, M5 X 12	4
38	VV13633	NUT, M5	2
39	AS22003	TOOTH WASHER, M5	2
40	VF40200	VALVE ASSY KIT	1
41	VF40001	TANK SEAL KIT	1
42	VF40132	HOSE BARB	1
43	VF40139	HOSE, SOLUTION	1
44	VF40000	TANK MOUNTING KIT	1
45	VF001U	SOLUTION TANK	1

AS17HD & AS20HD - BASE ASSEMBLY

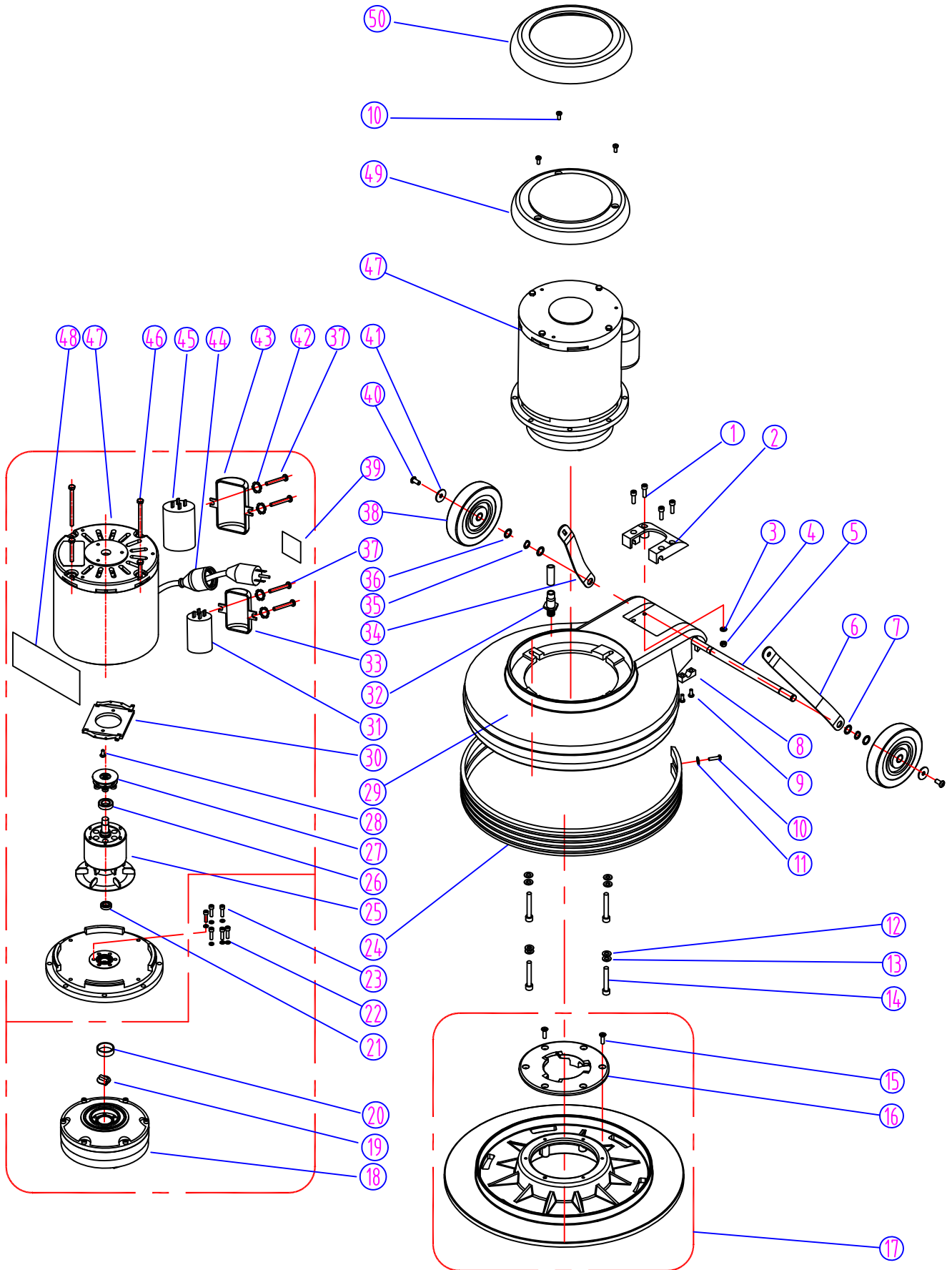

BASE ASSEMBLY

DIA NO	PART NUMBER	DESCRIPTION	NO REQ'D
1	GT13080	SCREW, M6 X 30	4
2	AS312201TP	PLATE,HANDLE GUIDE	1
3	GT13030	WASHER, PLAIN, M6	4
4	VF13502	NUT, LOCK, M6	4
5	VF30026	AXLE	1
6	VF30020	BRACKET, LEFT HANDLE	1
7	VV20274	WASHER, PLAIN, M13	4
8	GV40235	CLAMP BLOCK, AXLE	2
9	VV13621	SCREW, SELF-TAPPING, ST, M5 X 20	4
10	VA13474	SCREW, M5 X 16	5
11	VF13474A	WASHER, PLAIN, M5	4
12	VF13524	WASHER, PLAIN, M8	4
13	VF13519	WASHER, LOCK, M8	4
14	GT13016	SCREW, M8 X 55	4
15	MF-VF002-4A	SCREW, SELF-TAPPING, 1/4"-1"	6
16	MF-VF002-2	CLUTCH PLATE	1
17	MF-VF022	PAD HOLDER, 19"	1
18	VF999802B	GEAR BOX	1
19	VF99021	COUPLER	1
20	MT01102	SLEEVE	1
21	VF999821	BEARING,6002 LLU	1
22	VV13601	WASHER, LOCK, M5	6
23	VV13636	SCREW, M5 X 30	6
24	GV40233A	BUMPER, 20"	1
25	YCQ11200	ROTOR WITH FAN ASSY	1
26	YCQ10501	BEARING ,6203 RZ	1
27	YCQ10300A	CENTRIFUGAL SWITCH	1
28	VV20509	SCREW, M5 X 10	2
29	VF40100TP	FRAME,20"	1
30	YCQ10300B	STATIONARY SWITCH	1
31	VF999854	RUN CAPACITOR, 50uF / 370V	1
32	VF40152	HOSE BARB	1
33	YLQ14601	MOUNTING FRAME (SMALL), CAPACITOR	1
34	VF30019	BRACKET, HANDLE, RIGHT	1
35	VF13520	WASHER, LOCK	2
36	VF50119	WASHER, PLAIN, M12	2
37	VF14214	SCREW, M5 X 8	4
38	VF48202	WHEEL, 5"	2
39	VF40994	LABEL, READ MANUAL	1
40	VF44012	SCREW, M6 X 12.7	2
41	VF13666	WASHER, M6	2
42	VF13604	WASHER, LOCK, EXTERNAL TOOTH	4
43	YCQ10615	MOUNTING FRAME (BIG), CAPACITOR	1
44	AS41902	PLUG PROTECTOR, LARGE FEMALE	1
45	VF999805	START CAPACITOR (BIG), 400-450UF/150V	1
46	YLQ17507	BOLT ASSEMBLY	4
47	VF999787	MOTOR, 110V, 1.5HP	1
48	VF44003	LABEL, MOTOR	1
49	VF44001TP	TOP COVER, MOTOR	1
50	VF47023	BUMPER	1

Wiring Diagram

