

BOX EXTRACTORS

PRO SERIES

Pro 7R, Pro 10R and Pro 15R

SUPER SERIES

Super 7R and Super 10R

INTRODUCTION

OPERATING & MAINTENANCE INSTRUCTIONS

READ THIS BOOK

This operator's book has important information for the use and safe operation of this machine. Read this book carefully before starting the machine. Keep this book and tell all operators to read the book. If you do not follow the instructions, you can cause an injury or damage equipment, furniture or buildings.

For new books write to:

Pacific
2259 S. Sheridan
Muskegon, MI 49442-6252

Carefully inspect all components to ensure that there is no concealed freight damage. If such damage is discovered, file a "CONCEALED DAMAGE REPORT" immediately with the delivering carrier.

The contents of this manual are based on the latest product information available at the time of publication. Pacific Steamex reserves the right to make changes or improvements to its machines without notice.

**FOR YOUR CONVENIENCE, RECORD THE MACHINE
MODEL AND SERIAL NUMBER:**

MODEL _____

SERIAL NUMBER _____

PART NUMBER _____

DATE PURCHASED _____

IMPORTANT SAFETY INSTRUCTIONS

When using an electrical appliance, basic precautions should always be followed, including the following:

READ ALL INSTRUCTIONS BEFORE USING THIS MACHINE

WARNING: To reduce the risk of fire, electric shock, or injury:

1. You must have training in the operation of this machine before using it.
2. Machines can cause an explosion when near flammable materials and vapors. Do not use this machine with or near fuels, grain dust, solvents, thinners, or other flammable materials.
3. Do not operate this machine unless it is completely assembled.
4. Do not use this unit for dry pick-up of dust or debris. Do not pick up anything that is burning or smoking.
5. To prevent electric shock, always remove the electrical plug from the electrical outlet before doing any repairs or maintenance to this machine. Do not unplug by pulling on cord. To unplug, grasp the plug, not the cord.
6. To prevent injury, always remove the electrical plug from the electrical outlet before leaving the machine.
7. Maintenance and repairs must be done by authorized personnel only.
8. Do not immerse. To reduce the risk of electrical shock, use only on carpet moistened by the cleaning process. Protect the machine from rain. Keep the machine in a dry building. Always clean the machine with a clean dry cloth.
9. Always use a three-wire electrical system connected to the electrical ground. For maximum protection against electrical shock, use a circuit that is protected by a ground fault circuit interrupter. Consult your electrical contractor.
10. To prevent damage to the power cord, do not move this machine over the power cord. Always lift the power cord over the machine. Do not pull or carry cord, use cord as a handle, close a door on cord, or pull cord around sharp edges or corners. Keep cord away from heated surfaces.
11. Make sure all switches are turned off before plugging or unplugging it power cord into/from a wall receptacle.
12. Do not use water that is hotter than 60°C (140°F).
13. To prevent damage to the solution system components do not store in freezing temperatures without proper maintenance.
14. Do not use with damaged cord or plug. If the machine is not working as it should, has been dropped, damaged, left outdoors, or dropped into water, return it to a service center.
15. Do not handle the plug or machine with wet hands.
16. Do not put any object into openings. Do not use with any opening blocked. Keep free of dust, lint, hair and anything that may reduce the airflow.

Grounding Instructions

This machine must be grounded. If it should malfunction or break down, grounding provides a path of least resistance for electric current to reduce the risk of electric shock. This machine is equipped with a cord having an equipment-grounding conductor and grounding plug. The plug must be inserted into an appropriate outlet that is properly installed and grounded in accordance with all local codes and ordinances.

WARNING - Improper connection of the equipment-grounding conductor can result in a risk of electric shock. Check with a qualified electrician or service person if you are in doubt as to whether the outlet is properly grounded. Do not modify the plug provided with the machine - if it will not fit the outlet, have a proper outlet installed by a qualified electrician.

This machine is for use on a nominal 120-volt circuit, and has a grounded plug that looks like the plug illustrated in figure A. A temporary adapter that looks like the adapter illustrated in figures B and C may be used to connect this plug to a 2-pole receptacle as shown in figure B if a properly grounded outlet is not available. The temporary adapter should be used only until a properly grounded outlet (figure A) can be installed by a qualified electrician. The green colored rigid ear, lug, or the like extending from the adapter must be connected to a permanent ground such as a properly grounded outlet box cover. Whenever the adapter is used, it must be held in place by a metal screw.

NOTE: In Canada, the use of a temporary adapter is not permitted by the Canadian Electrical Code

EXTENSION CORDS

Use only three-wire 14/3 or larger gauge approved extension cords that have three-prong grounding type plugs and three-pole receptacles that accept the appliance's plug. Replace or repair any damaged cords or plugs.

When servicing, refer to authorized person only. Use only identical replacement parts.

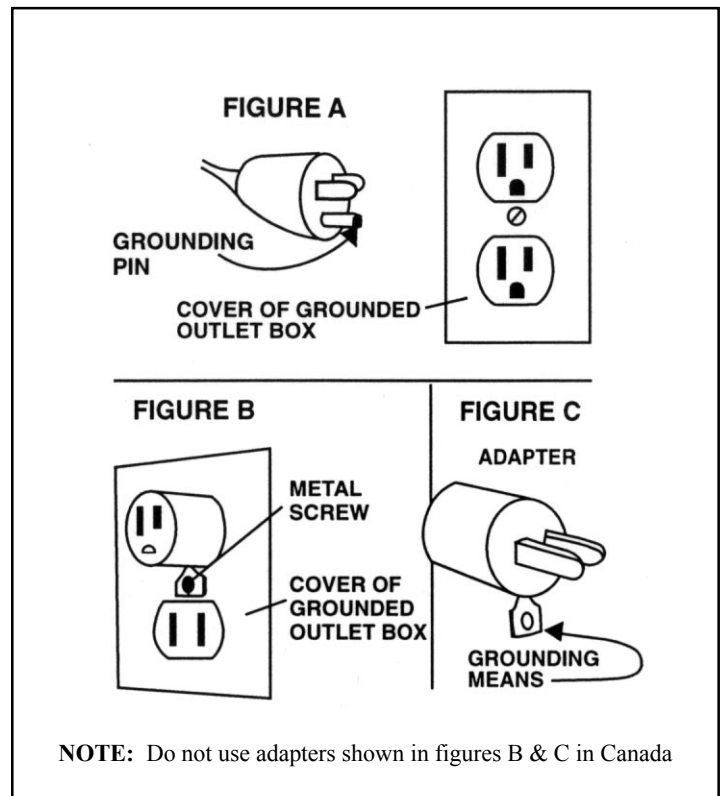

OPERATING AND MAINTENANCE PROCEDURES

PRESTART-UP CHECKS

This machine is simple and easy to operate. Very little maintenance and service is required to keep your machine in top operating condition.

The following procedures are recommended to maintain the high level of performance expected from your machine. They are also intended to identify potential safety hazards and problems which could reduce the service life of the machine.

READ BEFORE OPERATING YOUR MACHINE:

1. Check **power cord, plug** and **strain relief** for worn or damaged insulation. Repair or replace if necessary.
2. Make sure the plug is in the **drain hose** and placed in its storage position on the back of the tank.
3. Inspect the **vacuum head** on the wand for any damage. Burrs on the contact surface may snag carpet fibers. Gouges, scratches and chipped areas can reduce vacuum performance.
4. Check the **inlet strainer** located at the bottom of the solution tank for damage or debris. Holes in the screen can allow contaminants to enter the pump resulting in costly repairs. A clogged strainer will reduce pump performance and may cause permanent damage.
5. Unscrew the clear round **plastic cover** on top of the recovery (vacuum) tank.
 - a) Inspect the **cover** and **gasket** for damage. Dirt or debris on the gasket or sealing surface of the tank can cause a vacuum leak and reduce vacuum performance.
 - b) The **float assembly** consists of a screen and ball shut off to protect the vacuum motor. To remove it twist the assembly from the white vacuum tube. Then clean the screen of debris. It should be checked periodically for any damage and replaced when necessary.
 - c) **Replace the cover**, making sure it is securely in place.

OPERATION & MAINTENANCE

The following procedures are intended to describe and detail proper operation of your machine. Failure to follow these recommended procedures can reduce the machine's performance and may result in damage to the machine.

1. **Vacuum the area to be cleaned.** Your machine will do a more thorough job if the loose dirt and debris are removed before the extraction process begins.
2. **Fill the fresh water tank** (lower tank) with hot water and cleaning chemical. Do not use water hotter than 60°C (140°F). Mix in chemicals according to the chemical manufacturer's recommendations. Powdered chemical must be premixed with water before pouring into the solution tank.
3. Use of an extension cord is not recommended. However, if one is necessary, use only a 14 gauge or larger cord.
4. **Connect the wand assembly and hoses to the machine.** The solution hose simply inserts into the quick connect located on the front of the machine. The vacuum hose slides over the tube located on the front of the recovery (upper) tank.
5. Plug the power cord into a **grounded outlet** of the correct voltage. See Grounding Instructions.
6. The control panel contains the following:
 - a) **The pump switch should be turned on first.** The solution pump is self-priming and completely fills the system. The pump is a demand pump and operates when the valve trigger is activated or when the pressure is below the pump's pressure switch limit.
 - b) **Turn ON the vacuum switch.** You may now begin the cleaning process.
7. Depress the **valve trigger** on the wand to allow the solution water to flow.
8. Foaming may occur as dirty solution is recovered. Excessive foaming must be counteracted with liquid defoamer (follow the chemical manufacturers directions). **Do not allow foam to rise into or near the float assembly in the recovery tank.** Use defoamer or empty and flush the recovery tank.
9. When finished turn off the vacuum and pump switches, then unplug the power cord from the electrical outlet before doing any cleanup.
10. Always drain and clean the **recovery tank** after each use. Simply pull the plug from the drain hose on the back of the tank and drain. Dispose of the recovered water properly. Then flush out the tank with clean water making sure all deposits and debris are removed. Replace the plug and return the hose to its storage position on the back of the tank.
11. After each use **clean the cover, float assembly and gasket.** Do not reinstall the cover until the next use, this will allow the recovery tank to dry out.
12. Periodically check and clean the **inlet strainer** in the solution tank. Make sure the strainer is properly in place to protect the pump.
13. Wipe the machine down with a damp cloth.

PRO & SUPER

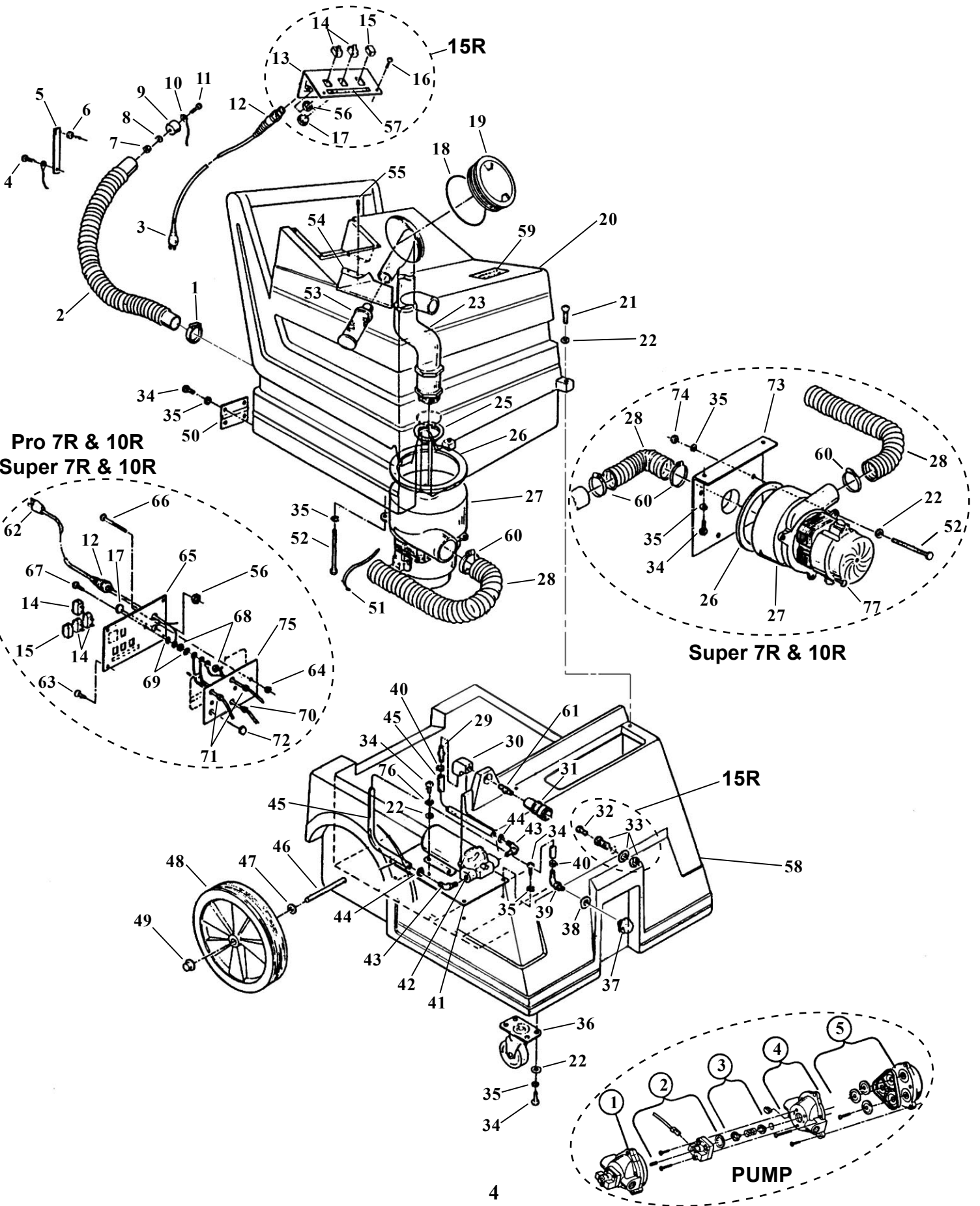

PRO & SUPER PARTS LIST

ITEM	PART NO.	DESCRIPTION	QTY.	ITEM	PART NO.	DESCRIPTION	QTY.
1	602012	Clamp - Hose	1	39	3771	Elbow - Male 1/4 to 3/8, 15R	1
2	604107	Hose - Drain Polyvac	1		211310	Body - 90 Jet, 7/10R	1
3	S266P1	Power Cord - 25', 15R only, (see item 62 for 7/10R cord)	1	40	202050	Clamp - Solution Hose	2
4	962015	Screw - 10-32 x 3/8	1	41	S303P	Plate-Pump Mounting, 7/10R	1
5	608508	Velcro Strap-Vac Hose Retainer	1		226670	Plate - Pump Mounting, 15R	1
	203473	Gasket - Strap , 15R only	1	42	3785V	Pump - 115 volt	1
6	603313	Fastener - 95707A685	1		3821V	Pump - 230 volt	1
7	920017	Nut - 10-24	1	43	3765	Elbow - Male 3/8 to 3/8	2
8	W107D	Washer - 3/16 Flat	1	44	S453P	Clamp - Hose	2
9	608504	Stopper - Drain	1	45	S250P	Hose - 3/8 Push Loc	3 ft.
10	602408	Cord - Stopper Stretch	1	46	227750	Shaft-Wheel, 7/10R	1
11	962113	Screw 10-24 x 1-1/4 S/S PHP	1		227770	Shaft - Wheel, 15R	1
12	A13020	Relief - Strain	1	47	W120D	Washer - 7/16 Flat	2
13	227050	Panel - Control, 15R	1	48	229750	Wheel - 10 x 1.75 Grey	2
14	911089	Switch - Rocker 16 amp	2	49	S482P	Snap Axle Cap 1/2	2
15	S519PB	Switch Blanks Black	1	50	204552	Hinge - Vac Tank	2
16	W351D	Screw 10-24 x 1/2, 15R only	4	51	911104	Tie - Cable	1
17	S799NP1	Plug - Nickel Plated 7/8	1	52	962122	Bolt-Tap 1/4-20x3 1/4 , 7/10R	3
18	223403	Gasket Cover	1		W196D	Screw 1/4 -20 x 4, 15R	3
19	222302	Cover - Cleanout	1	53	223370	Float Assembly	1
20	228651	Tank Vacuum - 7R	1		980630	Washer-Float Restrictor, Super	1
	228652	Tank Vacuum - 10R	1	54	221372	Baffle, 7/10R	1
	228673	Tank Vacuum - 15R	1		221371	Baffle, 15R	1
21	962083	Screw-1/4-20 x 1PHP, 7/10R	2		221360	Extra Baffle, Super 7/10R only	1
	962117	Screw-1/4-20x1-1/2PHP, 15R	2		W213D	Screw, 8-32x3/4FHP (for 221360)	2
22	W104D	Washer - 1/4 Flat	14	55	930006	Rivet - Pop 1/8 x 1/2, 15R	2
23	228550	Standpipe Assembly, 7R	1		930005	Rivet Alum Pop, 7/10R	2
	228551	Standpipe Assembly, 10R	1	56	920616	Nut - 1/2 NPT	1
	228571	Standpipe Assembly, 15R	1	57	225173	Label - Switch	1
25	A13012	Sealing Nut - 1-1/4	1	58	228653	Tank Solution, 7/10R	1
26	S446P1	Gasket - Blower Ring 3/8	1		228675	Tank Solution , 15R	1
27	A13504	Vac Motor - 115V, 15R	1	59	D161C	Decal - Defoamer	1
	3738	Vac Motor - 230V, 15R	1	60	S216P	Clamp - Hose	1
	S322P	Vac Motor-115V, Pro 7/10R	1	61	S906A	Brass-Long Nipple, 7/10R	1
	S589P	Vac Motor-230V, Pro 7/10R	1		205752	Nipple-Close 1/4 NPT	1
	S591P	Vac Motor-115V, Super 7/10R	2	62	908076	Cord ASM 14/3x25', 7/10R	1
	S589P	Vac Motor-230V Super 7/10R	2	63	962015	Screw 10-32x 3/8 Pan Hd	5
	210901	Carbon Brush for A13504	2	64	920017	Nut 10-24 ESNA	2
	200951	Carbon Brush for S322P	2	65	227051	Panel-Control, 7/10R	1
	210904	Carb.Brush for S589P&3738	2	66	962121	Screw 10-24x2 1/2 Pan Hd	2
	S591P1	Carbon Brush for S591P	2	67	W343D	Screw 10-24x1 PHP	1
28	224160	Hose	1.4 ft.	68	W106D	Nut 10-24 Hex	2
29	203359	Fitting - Hose Barb 3/8 Hose	1	69	980015	Washer-#10 Ext Tooth	2
30	S905A	Brass - 90 Degree	1	70	508519	Strain Relief	1
31	203308	Quick Connect - 1/4 Female	1	71	708502	Strain Relief	1
32	S804N1	Brass - Hex Head Plug 1/4, 15R	1	72	221350	Plug Button	1
33	T4056	Brass-cplg 1/4 w/nut/washer, 15R	2	73	225660	Mount-Vac Motor, Super	1
34	962006	Screw - 1/4-20 x 1/2	24	74	920004	Nut 1/4 -20 Hex, Super	3
35	980002	Washer - 1/4 Lock	15	75	226650	Plate-Switch Encl. Back, 7/10R	1
36	S130P	Caster	2	76	980022	Washer #10 Spring Lock, 7/10R	4
37	S626P	Strainer - 3/8 NPT	1		980002	Washer - 1/4 Lock, 15R	4
38	S479P	Brass-Reducer 3/8x1/4, 15R	1	77	962030	Screw 10-32x1/2 Type F PHP	1
	S372P	Washer:Nylon, 7/10R	1				

REPLACEMENT PARTS FOR PUMP

ITEM	PART NO.	DESCRIPTION	QTY.
1	204557	Pump Head	1
2	3788	Switch Kit	1
3	3787	Valve Kit	1
4	3786	Nylon Upper Housing	1
5	3789	Diaphragm Kit	1

ACCESSORIES

ITEM	PART NO.	DESCRIPTION	QTY.
	219804	Wand, 12" 2 Jet - See Page 6	1
	F213W2	Solution Hose, 15' - See Page 6	1
	F215W	Vacuum Hose, 15'	1

2 JET WAND

219804

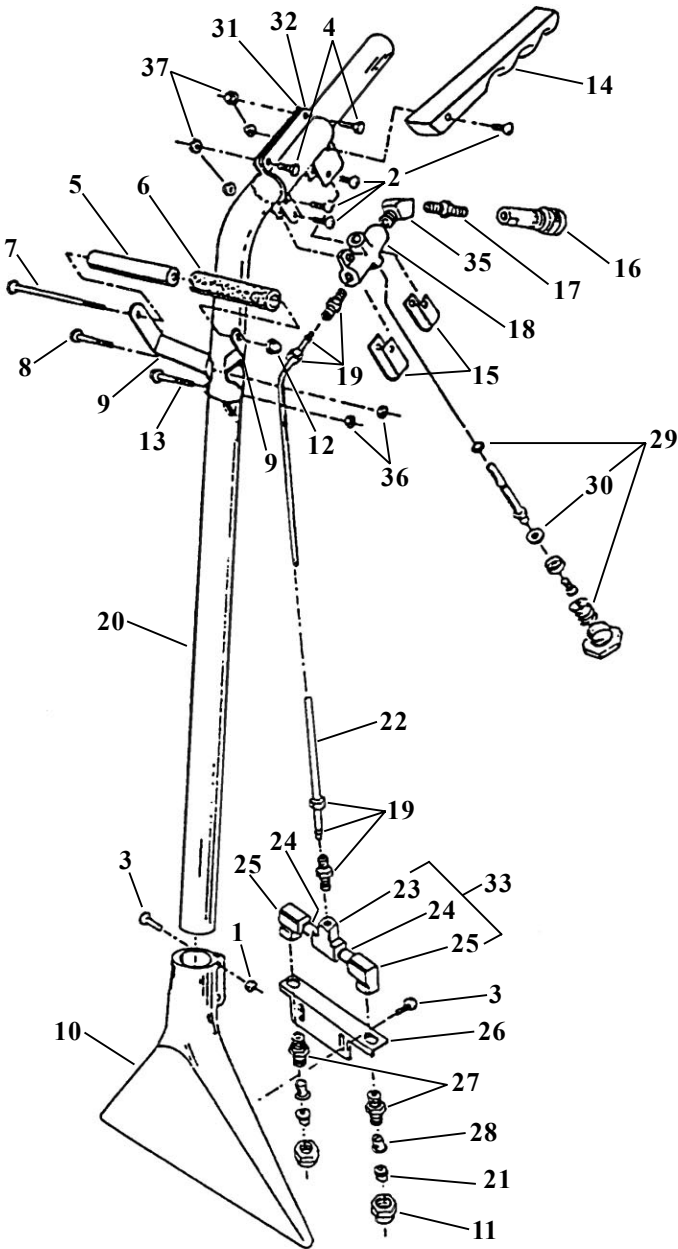

ITEM	PART NO.	DESCRIPTION	QTY.
1	W148D	Nut 1/4-20 Hex SS	2
2	W354D	Screw 10-24 x 1 PHP MS	4
3	W102D	Screw 1/4-20 x 5/8 PHP MS	4
4	W153D2	Screw 10-24 x 3/4 PHP	2
5	S399P	Poly Rod	1
6	S124R	Grip	1
7	W131D	Screw 1/4-20 x 5" HHCS	1
8	962010	Screw 1/4-20 x 1" HHCS	1
9	213904	Handle Bracket - Half	2
10	214502	Vac Head - Wheelabrated	1
11	S973P	Cap - Jet	2
12	W162D	Nut 1/4-20 Acorn Zinc	1
13	962068	Screw 1/4-20 x 5/8 HHCS	1
14	505120	Handle - Lever	1
15	218508	Bracket Valve Support	2
16	203308	Quick Connect 1/4" Female	1
17	S222N	Fitting - 1/4 to 1/4 Union	1
18	219403	Valve	1
19	S117P	Brass Compression Fitting	2
20	S601P	Wand Tube - Trogamented	1
21	S877P2	Jet 11003 Brass	2
22	S848P	Tube - Aluminum	1
23	S904A	Brass - Union Tee	1
24	S222N	Fitting - 1/4 to 1/4 Hex	2
25	S905A	Brass - 90° Elbow	2
26	S902A	Bracket	1
27	S980P	Body - Jet	2
28	S280P	Strainer - Check Valve	2
31	210806	Valve Bracket - Right	1
32	210807	Valve Bracket - Left	1
35	T4055	Brass 45° Street Elbow	1
36	920011	Nut 1/4-20 Hex w/Nyloc	2
37	W236D	Nut 10-24 Hex w/Nyloc	6
SERVICE KITS:			
29	215007	Valve Repair Kit, Includes: Spring, O-Ring & Washer (212707)	
30	212707	Valve Washer - Teflon	
33	215624	Manifold-2 Jet: Includes Items 23,24&25	

SOLUTION HOSE 15'

F213W2

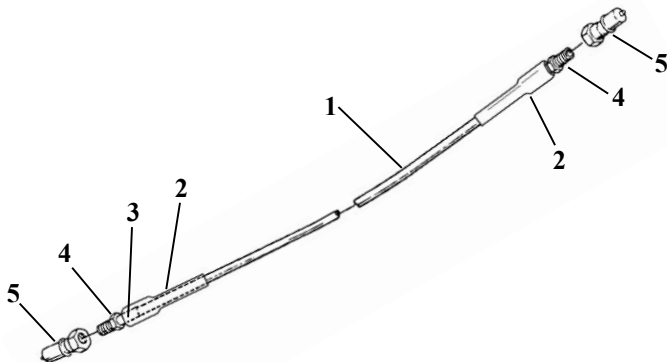

ITEM	PART NO.	DESCRIPTION	QTY.
1	S344P1	Hose 1/4 Gray	15'
2	217501	Relief - Pressure	2
3	S226P	Ferrule	2
4	S223P	Brass Barb 1/4 to 1/4 MPT	2
5	203302	Quick Connect 1/4" Male	2

WIRING DIAGRAMS

PRO 7R, 10R and 15R

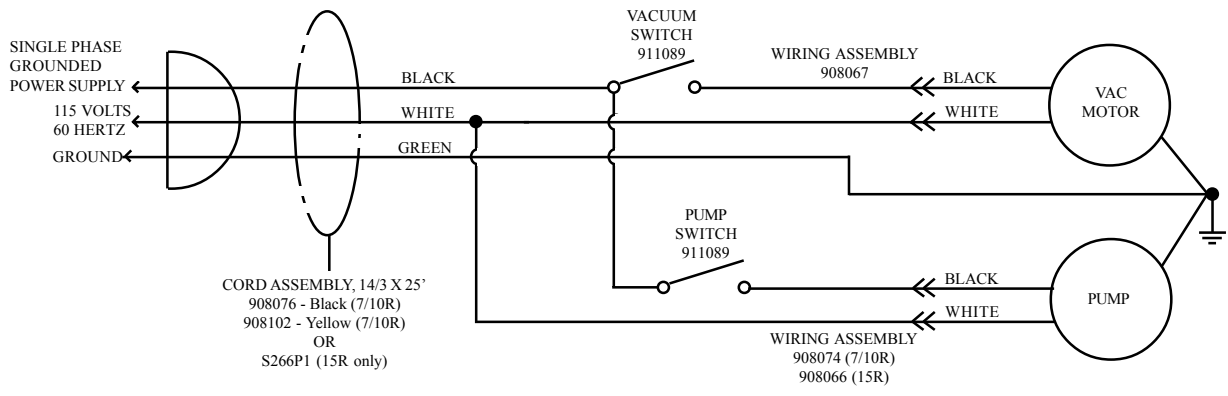

SUPER 7R and 10R

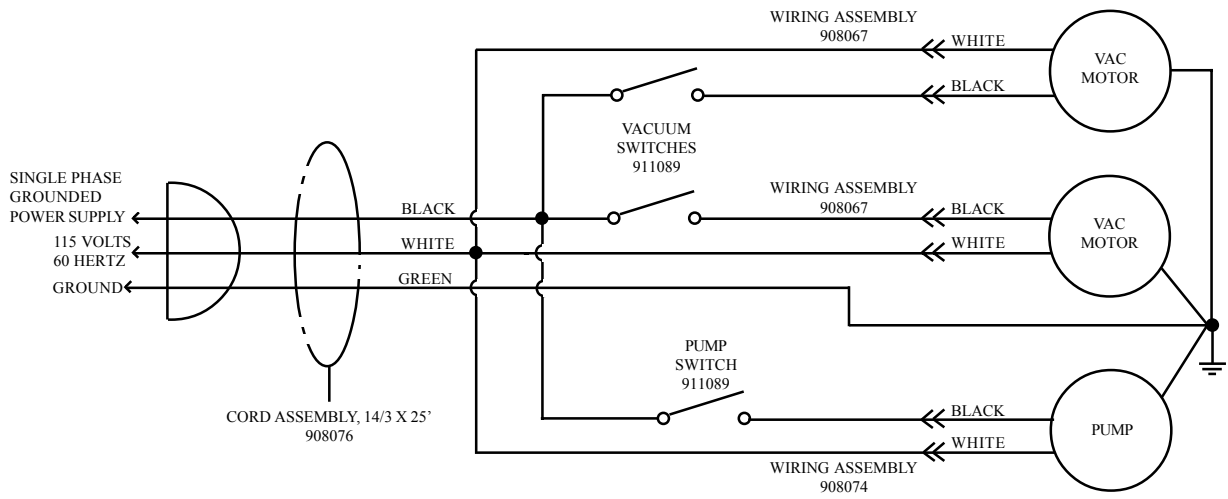

WARRANTY POLICY PACIFIC LIMITED WARRANTY

The **Pacific** Pro/Super Carpet Extractor has been manufactured, tested and inspected in accordance with specific engineering requirements and is **WARRANTED** to be free from defects in workmanship and materials as follows:

Five (5) years parts, One (1) year labor – Polyethylene components.
One (1) year parts & labor – All other components unless excluded below.

This warranty extends to the original user/purchaser and only when used, operated and maintained in accordance with **Pacific** Operating and Maintenance instructions.

This warranty does not apply to the following wear parts and accessories of the machine including:

Part Number	Part Name
908076	Cord Assembly, Black (7/10R)
908102	Cord Assembly, Yellow (7/10R)
S266P1	Cord Assembly, Black (15R) Cord Assembly, Yellow (15R)
229750	Wheel
S130P	Caster
S626P	Strainer
210901	Carbon Brush for A13504
200951	Carbon Brush for S322P
210904	Carbon Brush for S589P & 3738
S591P1	Carbon Brush for S591P
S877P2	Jet 11003
S280P	Strainer-Check Valve

Nor does it apply to damage or failure caused by improper use, abuse or neglect. Warranty credit or replacement of return parts including motors, pumps, etc., is subject to incoming inspection of those items.

To secure repair under this warranty, the following procedure should be taken:

- The inoperative machine or warranted parts must be delivered to the authorized dealer with shipping and delivery charges prepaid. If unable to locate the Dealer, you may contact **Pacific** at the address listed herein for the location of the nearest **Pacific** repair center or agent or for other instructions pertaining to your warranty difficulty.
- Upon compliance with the above warranty procedure, all warranted repairs would be completed at no additional charge or cost to the user.
- Only **Pacific** or its authorized dealers and agents may make no charge warranty repairs on this product. All others do so at their own risk.

This warranty limits **Pacific** liability to the repair of the product and/or warranted parts replacement and does not include incidental or consequential damages arising from the use of a **Pacific** machine whether defective or not.

This warranty is in lieu of all other expressed or implied warranties and is extended to the original purchaser/user.

PACIFIC

2259 Sheridan

Muskegon, Michigan 49442

Ph: (800) 968-1332 Fax: (231) 773-1642

www.nextwaveofclean.com