

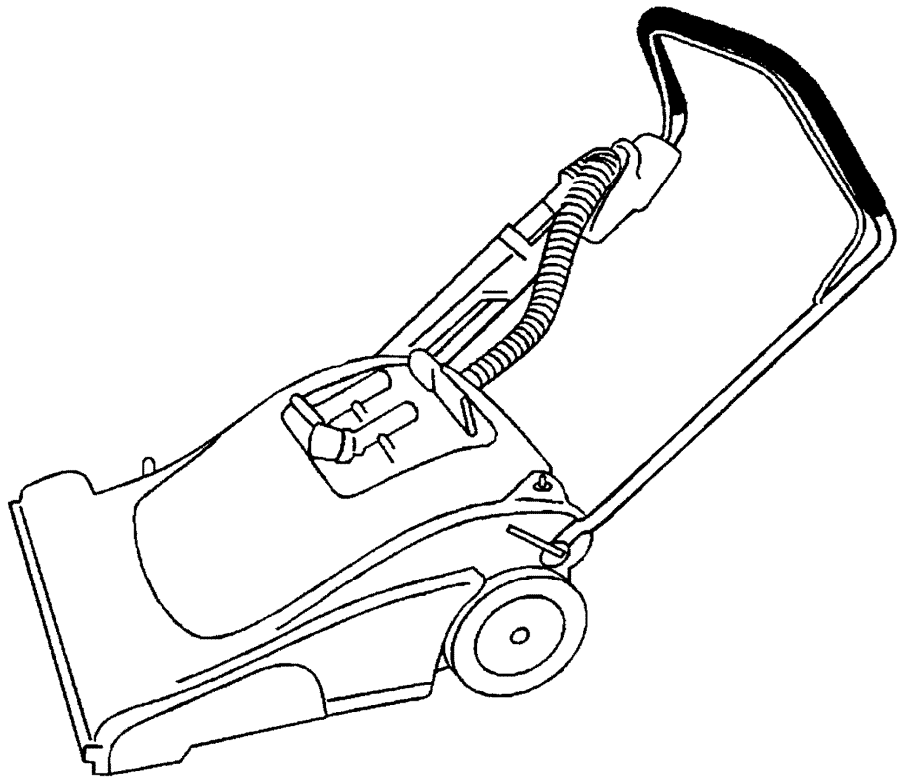

# KÄRCHER

**Model:** CV71/2  
1.012-564.0



---

Operating Instructions (ENG)



86343460-A  
05/21/10



**CLICK TO ORDER PARTS**

## **MACHINE DATA LOG/OVERVIEW**

Model:	_____
Date of Purchase:	_____
Serial Number:	_____
Sales Representative:	_____
Address:	_____
Phone Number:	_____

### **OVERVIEW**

The **CV71/2** is a electric motor powered, wide area vacuum intended for commercial use. The **CV71/2** brushes and vacuums debris from carpeted surfaces and stores the collected debris in vacuum bags.

# TABLE OF CONTENTS

*Machine Data Log/Overview*..... 1  
*Table of Contents*.....3

## HOW TO USE THIS MANUAL

*How to use this Manual*..... 1-1

## SAFETY

*Important Safety Instructions* .....2-1  
*Hazard Intensity Level*. ....2-2  
*Grounding Instructions*.....2-3

## OPERATIONS

*Controls*.....3-1  
*Machine Operation*.....3-2  
    *Set Up*.....3-2  
    *Operation*. ....3-2  
    *Cleaning*.....3-2

## MAINTENANCE

*Belt/Brush Access*.....4-1  
*Vac Motor Access & Filters*.....4-1  
*Vac Motor Brush Removal*.....4-1  
*Brush Motor*. ....4-1  
*Carbon Brush*.....4-1  
*Daily Maintenance*. ....4-2  
*Regular/Periodic Maintenance*.....4-2  
*Wiring Diagram*. ....4-3  
*Service Schedule*.....4-4

## GROUP PARTS LIST

*Brush and Drive Group*. ....5-1  
*Brush Height and Wheel Group*.....5-3  
*Vacuum Group*.....5-5  
*Handle Group*.....5-7  
*Lid/Decal Group*.....5-9  
*Electrical Panel and Cover Group*.....5-11  
*Suggested Spare Parts*.....5-13

## HOW TO USE THIS MANUAL

This manual contains the following sections:

- HOW TO USE THIS MANUAL
- SAFETY
- OPERATIONS
- MAINTENANCE
- PARTS LIST

The HOW TO USE THIS MANUAL section will tell you how to find important information for ordering correct repair parts.

Parts may be ordered from an authorized dealers. When placing an order for parts, the machine model and machine serial number are important. Refer to the MACHINE DATA box which is filled out during the installation of your machine. The MACHINE DATA box is located on the inside of the front cover of this manual.

Model: _____
Date of Purchase: _____
Serial Number: _____
Sales Representative: _____
Address: _____
Phone Number: _____

The model and serial number of your machine is on the bottom back-end of the machine.

The SAFETY section contains important information regarding hazard or unsafe practices of the machine. Levels of hazards is identified that could result in product or personal injury, or severe injury resulting in death.

The OPERATIONS section is to familiarize the operator with the operation and function of the machine.

The MAINTENANCE section contains preventive maintenance to keep the machine and its components in good working condition. They are listed in this general order:

- Belt/Brush Motor
- Vac Motor and Filters
- Vac Motor Carbon Brushes
- Brush Motor
- Carbon Brush
- Daily Maintenance
- Regular/Periodic Maintenance

The PARTS LIST section contains assembled parts illustrations and corresponding parts list. The parts lists include a number of columns of information:

- **REF** – column refers to the reference number on the parts illustration.
- **PART NO.** – column lists the part number for the part.
- **PRV NO.** – reference number.
- **QTY** – column lists the quantity of the part used in that area of the machine.
- **DESCRIPTION** – column is a brief description of the part.
- **SERIAL NO. FROM** – column indicates the first machine the part number is applicable to. When the machine design has changed, this column will indicate serial number of applicable machine. The main illustration shows the most current design of the machine. The boxed illustrations show older designs. If column has an asterisk (\*), call manufacturer for serial number.
- **NOTES** – column for information not noted by the other columns.

*NOTE: If a service or option kit is installed on your machine, be sure to keep the KIT INSTRUCTIONS which came with the kit. It contains replacement parts numbers needed for ordering future parts.*

# IMPORTANT SAFETY INSTRUCTIONS

When using an electrical appliance, basic precaution must always be followed, including the following:

READ ALL INSTRUCTIONS BEFORE USING THIS MACHINE.

**⚠ WARNING:** To reduce the risk of fire, electric shock, or injury:

**Use only** indoors. Do not use outdoors or expose to rain.

**Use only** as described in this manual. Use only manufacturer's recommended components and attachments.

If the machine is **not working properly**, has been dropped, damaged, left outdoors, or dropped into water, return it to an authorized service center.

**Do not** operate the machine with any openings blocked. Keep openings free of debris that may reduce airflow.

This machine **is not** suitable for picking up hazardous dust.

**Machine can cause a fire** when operating near flammable vapors or materials. Do not operate this machine near flammable fluids, dust or vapors.

**This machine is suitable for commercial use, for example in hotels, schools, hospitals, factories, shops and offices for more than normal housekeeping purposes.**

Maintenance and repairs **must be done** by qualified personnel.

**During operation**, attention shall be paid to other persons, especially children.

**When leaving unattended**, secure against unintentional movement.

**The machine shall only** be operated by instructed and authorized persons.

**When leaving unattended**, switch off or lock the main power switch to prevent unauthorized use.

**Do not** handle the plug or machine with wet hands.

**Do not** unplug machine by pulling on cord. To unplug, grasp the plug, not the cord.

**Do not** use with damaged cord or plug. Follow all instructions in this manual concerning grounding the machine.

**Do not** pull or carry by cord, use cord as a handle, close a door on cord, or pull cord around sharp edges or corners.

**Do not** pull/run machine over cord. **Keep** cord away from heated surfaces.

Connect to a **properly** grounded outlet. See Grounding Instructions.

## SAVE THESE INSTRUCTIONS

## **HAZARD INTENSITY LEVEL**

The following symbols are used throughout this guide as indicated in their descriptions:

### **HAZARD INTENSITY LEVEL**

There are three levels of hazard intensity identified by signal words -**WARNING** and **CAUTION** and **FOR SAFETY**. The level of hazard intensity is determined by the following definitions:

#### **! WARNING:**

**WARNING** - Hazards or unsafe practices which COULD result in severe personal injury or death.

#### **! CAUTION:**

**CAUTION** - Hazards or unsafe practices which could result in minor personal injury or product or property damage.

#### ***FOR SAFETY: To Identify actions which must be followed for safe operation of equipment.***

Report machine damage or faulty operation immediately. Do not use the machine if it is not in proper operating condition. Following is information that signals some potentially dangerous conditions to the operator or the equipment. Read this information carefully. Know when these conditions can exist. Locate all safety devices on the machine. Please take the necessary steps to train the machine operating personnel.

#### ***FOR SAFETY:***

**DO NOT OPERATE MACHINE:**

Unless Trained and Authorized.

Unless Operation Guide is Read and understood.

In Flammable or Explosive areas.

In areas with possible falling objects.

#### ***WHEN SERVICING MACHINE:***

**Avoid moving parts. Do not wear loose clothing; jackets, shirts, or sleeves when working on the machine. Use approved replacement parts.**

## GROUNDING INSTRUCTIONS

**THIS PRODUCT IS FOR COMMERCIAL USE ONLY.**

### ELECTRICAL:

In the USA this machine operates on a standard 15 amp 115V, 60 hz, A.C. power circuit . The amp, hertz, and voltage are listed on the data label found on each machine. Using voltages above or below those indicated on the data label will cause serious damage to the motors.

### EXTENSION CORDS:

If an extension cord is used, the wire size must be at least one size larger than the power cord on the machine, and must be limited to 50 feet (15.5m) in length.

### GROUNDING INSTRUCTIONS:

This appliance must be grounded. If it should malfunction or break down, grounding provides a path of least resistance for electric current to reduce the risk of electric shock. This appliance is equipped with a cord having an equipment-grounding conductor and grounding plug. The plug must be inserted into an appropriate outlet that is properly installed and grounded in accordance with all local codes and ordinances.

This appliance is for use on a nominal 120-volt circuit, and has a grounded plug that looks like the plug in "Fig. A". A temporary adaptor that looks like the adaptor in "Fig . C" may be used to connect this plug to a 2-pole receptacle as shown in "Fig. B", if a properly grounded outlet is not available. The temporary adaptor should be used only until a properly grounded outlet (Fig. A) can be installed by a qualified electrician. The green colored rigid ear, lug, or wire extending from the adaptor must be connected to a permanent ground such as a properly grounded outlet box cover. Whenever the adaptor is used, it must be held in place by a metal screw.

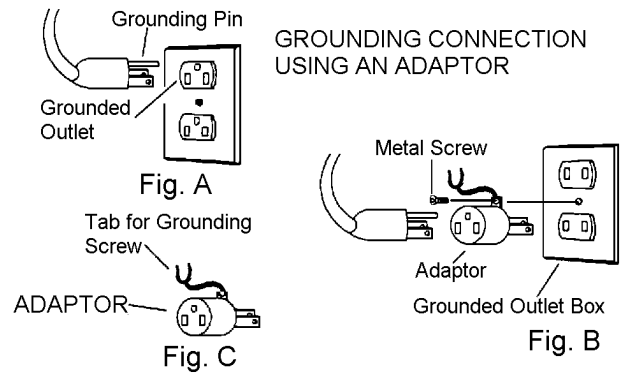

Note: Adaptors are not allowed in Canada.

Improper connection of the equipment-grounding conductor can result in a risk of electric shock. Check with a qualified electrician or service person if you are in doubt as to whether the outlet is properly grounded. Do not modify the plug provided with the appliance - if it will not fit the outlet, have a proper outlet installed by a qualified electrician.

## CONTROLS

1. **Main Handle.** Adjusts for operator comfort and storage.
2. **Brush on/off lever.** Activates brush when depressed.
3. **Accessory vacuum hose and wand.** Allows operator to clean edges, recessed, ledges, upholstery, etc.
4. **Detail tools** Dusting brush, crevice and upholstery tools for above the floor cleaning. Dusting brush comes with adapter for attachment directly to hose. Upholstery and crevice tool connect directly to both the hose and the wand. The crevice tool fits loosely on the wand.
5. **Handle Adjustment Lever.** Located on the left side of handle. Pull away from handle to loosen, adjust handle and press parallel to handle.
6. **Vac on/off switch.** Turns on and off vac motor.
7. **Brush motor circuit breaker.** Provides overcurrent protection for the brush motor.
8. **Vac motor circuit breaker.** Provides overcurrent protection for the vacuum motors.
9. **Exhaust filter.** Filters exhaust air for safe and quiet operation.
10. **Accessory hose activation pedal.** Press pedal down to use the accessory hose. Lift up with toe for normal use.
11. **Brush adjustment lever.** Allows operator to adjust brush to proper height for the carpet. (1) for low nap carpet, (5) for thick nap. Position (6) is storage.
12. **Dust bag cover.** Raise to allow access to dust bag and vac motors.
13. **Cloth dust bag.** High filtration cloth bag with zipper opening to access paper bag.
14. **Paper bag.** Fits within cloth bag for clean and easy dust removal.

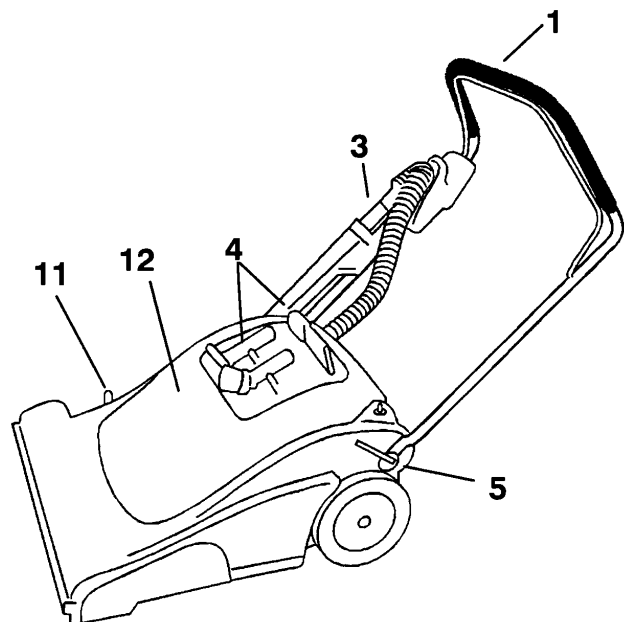
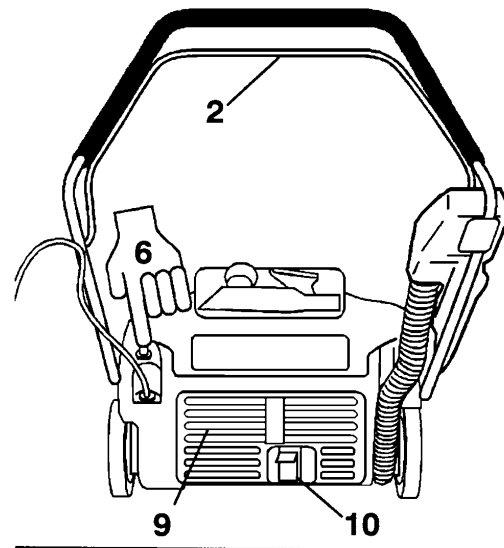
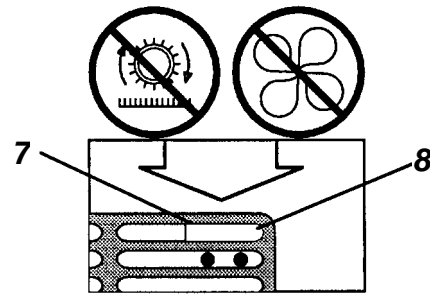

## STORAGE POSITION

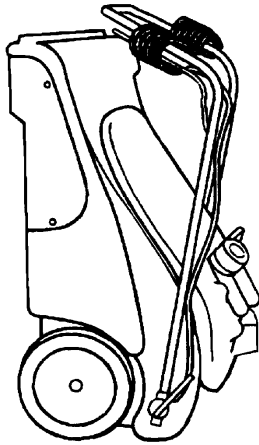

## FILTER/BAG COMPARTMENT

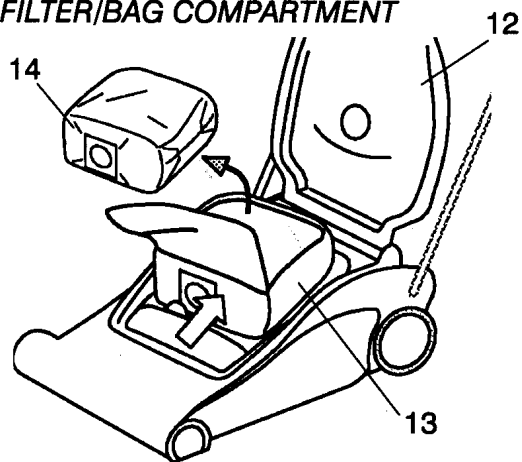

## STRAIN RELIEF

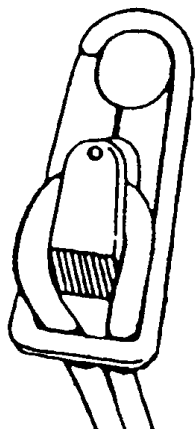

## MACHINE SET UP

1. Take machine out of storage position by lowering onto all four wheels.
2. Adjust handle to comfortable position at waist level by opening adjustment lever on left side of machine and moving handle. Lock back into position by closing adjustment lever.
3. Install cloth filter bag inside the main body by pushing the rubber collar over the chute.
4. Unzip the cloth bag and place the paper bag inside. Push the rubber gasket seal over the chute. Zip cloth bag closed taking care not to damage the paper bag and close lid.
5. Attach the detail tools to the top of the dust bag cover by pressing the appropriate tool into the clips.
6. Take the accessory wand and attach to the hose and insert wand into the wand holster.
7. Strain relief.

*NOTE: Attach strain relief/cord retainer to the power cord.*

1. Make a loop in power cord approximately 12" from receptacle end.
2. Slide cord loop through slot in retainer arm. Pull slack cord back through slot to secure. Attach retainer to handle.

## OPERATION

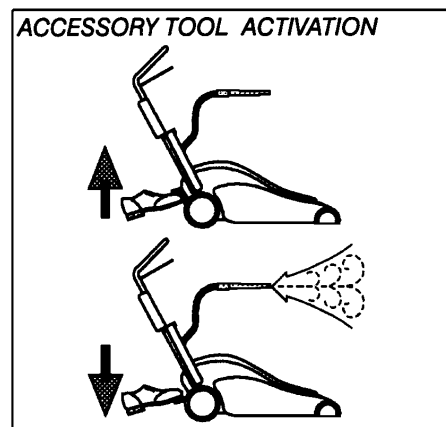
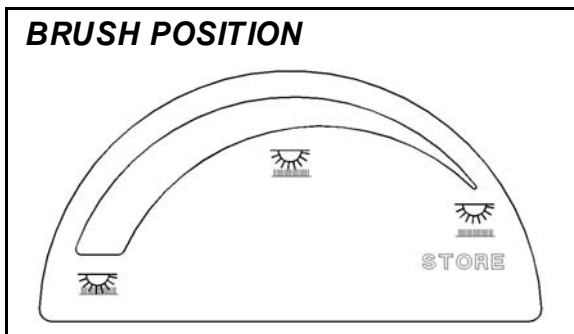
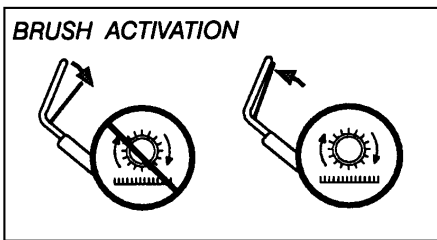
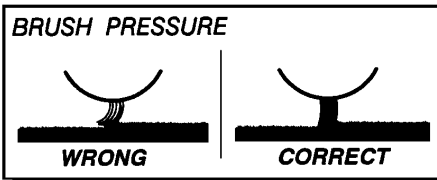
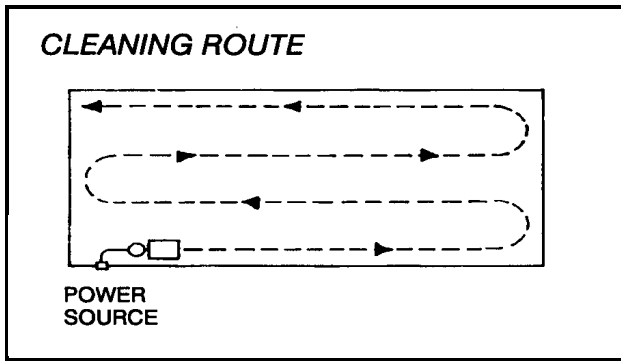

### HOW IT OPERATES

This machine is a portable, easy to use wide area vacuum designed for use indoors, in a commercial or light industrial environment.

When operating as a carpet vacuum, soil is lifted from the carpet surface by a rotating brush and carried into a removable bag by the vacuum motors.

1. Large debris such as paper cups, plates, etc., should be picked up before starting the cleaning process.
2. Plan your cleaning route to work away from the electrical source. Move machine forward at a steady pace.

### CLEANING

1. Adjust handle to comfortable position at waist level or higher.
2. Use your finger to depress the Vacuum switch at the base of the handle to activate the vacuum.
3. To adjust brush height, move the Brush Adjustment lever on the right side to the correct setting for the carpet being vacuumed. Lower brush gradually until firm brush contact is heard.

### **! WARNING:**

**KEEP MACHINE MOVING WHILE BRUSH ENGAGED. DAMAGE TO CARPET COULD OCCUR IF NOT MOVING.**

*NOTE: Always return brush to storage position after using machine.*

4. Depress the brush lever at the handle to start the brush.
5. Move forward at a steady pace for through cleaning. Run machine more slowly over extremely soiled areas.
6. Use the right side of the machine for edge cleaning.
7. To use the accessory wand and detail tools, depress the foot lever in the back of the machine.
8. To keep the vacuum operating at maximum efficiency, check the dust bag regularly. Empty when 1/2 to 3/4 full. Always use with disposable paper bag for best results.
9. When finished vacuuming, coil the cable by hand by looping into about a 3 foot diameter, Hang coiled cable over handle. Wrap the end around the cable loop to secure.
10. Return brush to storage position.

Note: The following service items should be performed by an authorized service facility or authorized service personnel. All parts preferred to in these instructions can be identified by using the parts lists and illustrations on the following pages.

## **WARNING:**

**Remove machine power cord from electrical source before making any repairs or adjustments to the machine.**

### ***TO ACCESS BELT/BRUSH MOTOR***

1. Place machine in the upright storage position.
2. Remove (3) screws holding belt cover to chassis.
3. Loosen brush motor and roll belt off brush pulley.
4. Remove (5) screws holding brush housing to chassis- (3) Located on front of housing, (2) Located rear of housing.
5. Remove (2) screws from each end of brush housing and remove brush assembly.
6. Inspect/replace brush and bearings as required. The brush is equipped with a yellow wear indicator bristles. The brush should be replaced when it wears down to the height of the yellow bristles.
7. When installing belt push down on motor for proper tension.
8. When reinstalling brush, check belt for proper tension.

### ***TO ACCESS AND REMOVE VAC MOTOR AND FILTERS.***

1. Open lid cover.
2. Remove (2) screws from each/both vacuum motor brackets.

## MAINTENANCE

### Vacuum Motor Carbon Brushes Replacement

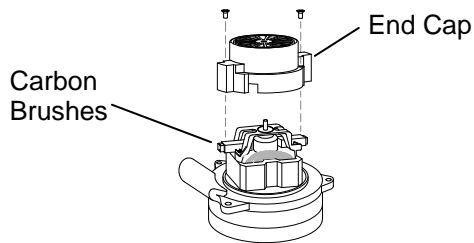

If armature commutator is grooved, extremely pitted or not concentric, the motor will need to be replaced or sent to a qualified service center.

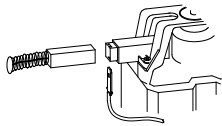

#### Important:

These brushes wear quicker as the length shortens due to increased heat. Spring inside brush housing will damage motor if brushes are allowed to wear away completely.

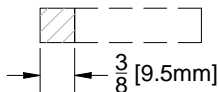

Periodically check the length of the carbon brushes. Replace both carbon brushes when either is less than  $\frac{3}{8}$ " (9.5mm) long.

*Note: Before reinstalling brush motor bracket assembly it's recommended that the rear spring be reconnected to the flapper assembly.*

*Note: part no. 86001250 – prv no. 140212 if you have a motor marked "leeson." Part no. 86135360 – prv no. 14340 if you have a motor marked "86247470 – prv no. 53617."*

### DAILY MAINTENANCE

1. Shake down bag daily.
2. Check power cord for damaged or frayed insulation.
3. Return brush adjustment lever to "STORE" position when the machine is not in use.
4. Check for and remove any lint or debris around brush and brush housing.

### REGULAR/PERIODIC MAINTENANCE

1. Every 4 to 6 months remove wheels, clean axles, and apply a thin coat of silicone lubricant to axles.
2. The filter bag can be washed twice before losing the filtering capability. This should be done using a mild detergent in cool water and hung up to drip-dry.
3. Inspect and clean vac motor filters.
4. Periodically inspect all hoses, electrical cables, filters, gaskets and connections on your machine. Frayed or cracked hoses should be repaired or replaced to eliminate vacuum loss.
5. The electrical cable must be well insulated, if the cable insulation is broken or frayed, repair or replace it immediately. Don't take chances with electrical fire or shock.

## ⚠ WARNING:

**The green ground wire must attach the motor to the power cord for safe operation. See the wiring diagram.**

*Note: When replacing electrical component parts refer to wiring diagram for proper connection.*

*Note: The vac motor is protected by a circuit breaker located in the switch panel. The breaker will only trip under conditions of abuse.*

### BRUSH MOTOR

1. Access belt and brush as described above.
2. Disconnect spring holding frame to brush motor housing.
3. Remove (4) bolts holding motor housing to the chassis and lift out motor asm.
4. Remove brush motor pulley and (2) bolts holding motor to bracket, lift out brush motor.

### CARBON BRUSH

1. Access belt and brush as described above.
2. Remove brush caps. *Note: Brushes should be replaced when worn to  $\frac{3}{8}$ " or less.*

# WIRING DIAGRAM

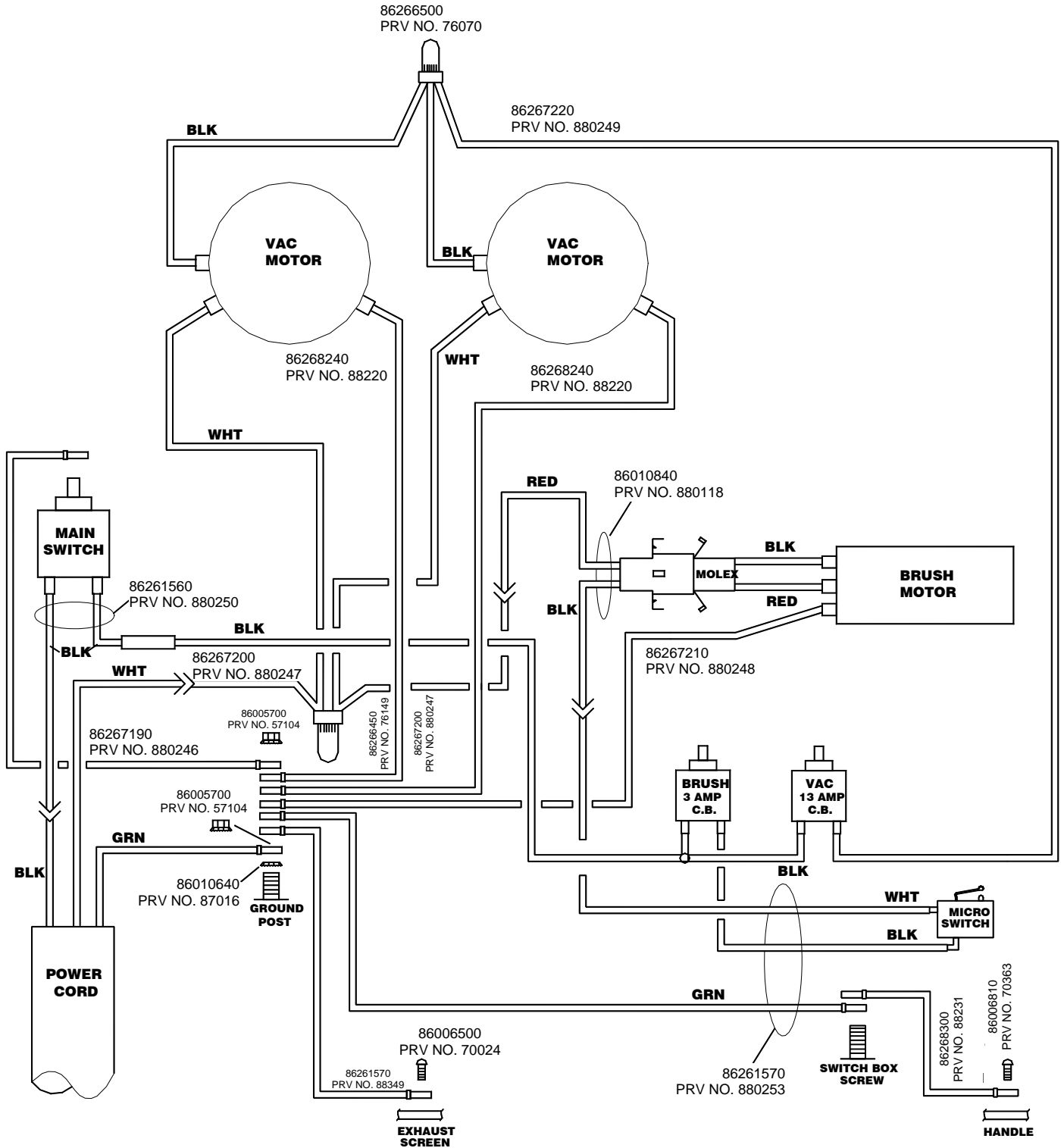

# MAINTENANCE

## SERVICE SCHEDULE

MAINTENANCE	DAILY	WEEKLY	MONTHLY	QUARTERLY
Check bag and replace if necessary	*			
Check filters and replace if necessary	*			
Check hoses for wear, blockages, or damage	*			
Inspect base for clogs	*			
Check swivel neck for clogs; remove clogs with fingers (if appropriate)	*			
Check major gaskets for leakage	*			
Check brush-should be clean with no lint or strings attached	*			
Wind cord and store in upright position	*			
Check hoses for cracks or holes		*		
Check all cords and handles for damage or cracks; replace as necessary		*		
Check brushes for wear; replace if necessary		*		
Check brush strip for wear; replace if necessary		*		
Inspect and replace all filters including exhaust, intake, and microfilters			*	
Inspect, clean, and repair power head – including brush housing			*	
Check all bearings for fiber build-up and noise			*	
Check all gaskets for wear and leakage			*	
Check belts for wear; replace if necessary			*	
Check vac motor carbon brushes				*
Check for arcing and pitting on any electrical contacts; replace if found				*
Inspect and clean vac shoe; check for dents and damage which would detrimentally effect vacuum and brush movement				*
Check overall performance of machine				*

***THIS PAGE LEFT BLANK INTENTIONALLY***

# BRUSH AND DRIVE GROUP

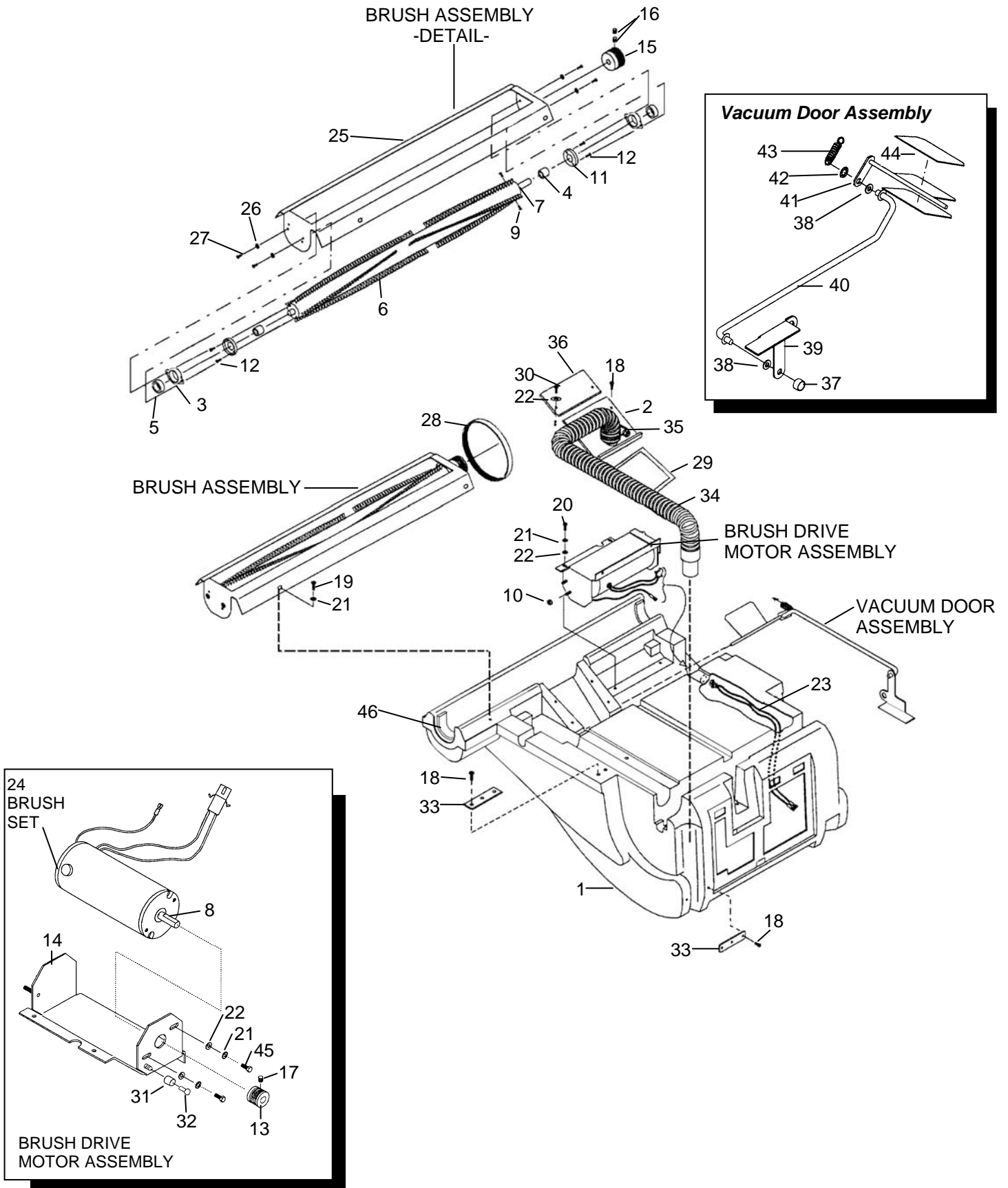

## BRUSH AND DRIVE GROUP PARTS LIST

REF	PART NO.	PRV NO.	QTY	DESCRIPTION	SERIAL NO. FROM	NOTES:
1	86341860	-	1	BODY, CV 71/2		
2	86011010	89199	1	WELDMENT, HOSE CONNECT		
3	86229050	14342	2	BEARING BLOCK		
4	86008210	73998	2	SPACER, .75OD X .5ID X .5L		
5	86000900	09019	2	BEARING, 1.125OD X .50ID X .375		
6	86001130	12039	1	BRUSH		
7	86000740	03112	1	AXLE, .5OD X 29.94L		
8	86026100	53623	1	MOTOR ASM, BRUSH DRIVE		
9	86006510	70043	2	SCR, 10-32 X 5/8 PFHMS		
10	86005710	57105	1	NUT, 1/4-20 HEX W/ STAR WASHER		
11	86004080	36197	2	GUARD, THREAD		
12	86007060	70710	4	SCR, 8-18 X 1/2 PFHST H-L		
13	86250420	64022	1	PULLEY, POLY V-BELT MOTOR		
14	86081840	62841	1	PLATE, MOTOR MOUNTING		
15	86006040	64104	1	PULLEY, BRUSH		
16	86277930	70119	2	SET SCR, 1/4-20 X 3/8		
17	86006550	70074	2	SET SCR, 10-32 X 1/4 KCP		
18	86006600	70114	6	SCR, #10 X 3/4 POLYFAST		
19	86276700	70716	5	SCR, 1/4-20 X 1/2 PPHMS PLTD		
20	86275570	70505	4	SCR, 1/4-20 X 1.0 HHCS PLTD.		
21	86010660	87025	11	WASHER, 1/4 LCK EXT STAR SS		
22	86010740	87090	8	WASHER, 1/4ID X 3/4OD		
23	86010840	880118	1	WIRE ASM, BRUSH MOTOR		
24	86135360	14340	1	BRUSH SET, BRUSH MTR		
25	86087030	73992	1	SHOE, VAC		
26	86010640	87016	4	WASHER, #10 LOCK EXT STAR SS		
27	86000680	70361	4	SCR, 10-32 X 1/2 PHTR PLTD		
28	86001090	11041	1	BELT, 220 J-6 POLY-V		
29	86198530	99809	3.42'	FOAM TAPE, 1/8T X 3/4 1SDA		
30	86276040	70586	2	SCR, 1/4-20 X 3/4 BLK PPHTC		
31	86008200	73996	1	SPACER, .50OD X .37ID X .44L SS		
32	86005860	57273	1	NUT, 1/4-20 X 12MM HEX BARREL		
33	86080950	62650	2	PLATE, VAC HOSE RETAINER		
34	86004270	39480	1	HOSE ASM, 1.5 X 30.0 BLK VAC		
35	86002380	20046	1	CLAMP, 2.25" WORM GEAR		
36	86006300	66329	1	PLATE, ACCESS		
37	86002810	27063	1	COLLAR, 3/8 SHAFT		
38	86010680	87030	2	WASHER, 3/8ID X 3/4OD X 1.25		
39	86006280	66281	1	PEDAL, WAND ACTIVATOR		
40	86005060	51277	1	LINKAGE, WAND ACTIVATOR		
41	86003380	29202	1	DOOR, FLAPPER		
42	86270910	57042	1	NUT, 3/8 PUSHLOCK		
43	86007690	73240	1	SPRING, EXT. 0.5OD X 2.25L X .063W		
44	86305040	-	-	GASKET, FLAPPER		
45	86274750	70270	2	SCR, 1/4-20 X 3/4 HHCS		
46	86133710	99862	6"	TAPE, 5/8W X 1/4T PORON 4701-01		

# BRUSH HEIGHT AND WHEEL GROUP

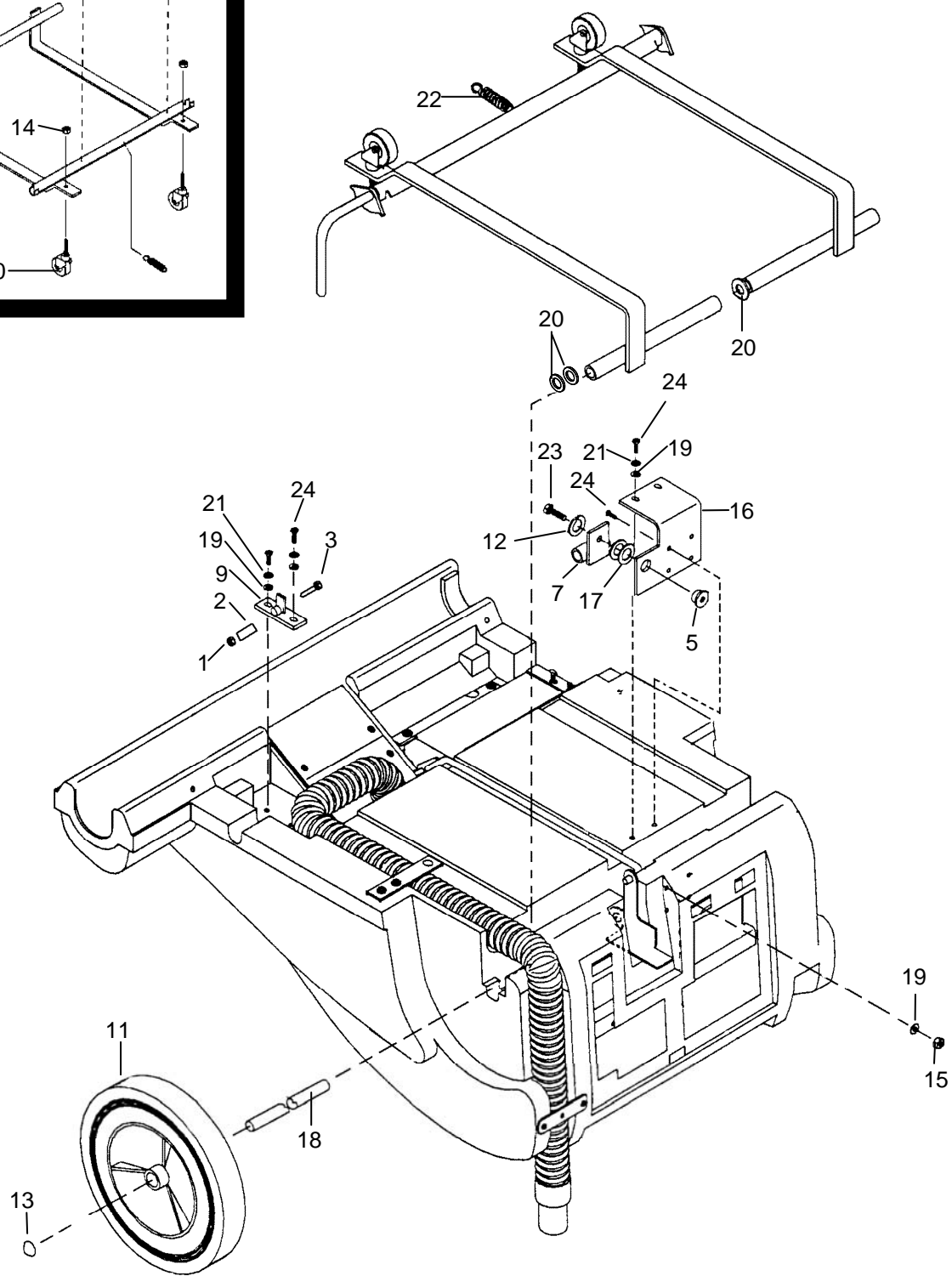
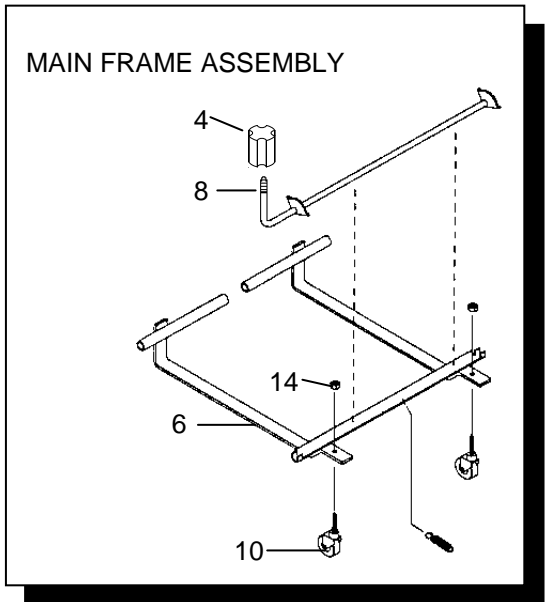

## **BRUSH HEIGHT AND WHEEL GROUP PARTS LIST**

REF	PART NO.	PRV NO.	QTY	DESCRIPTION	SERIAL NO. FROM	NOTES:
1	86005860	57273	1	NUT, 1/4-20 X 12MM HEX BARREL		
2	86008200	73996	1	SPACER, .50OD X .37ID X .44L SS		
3	86006660	70190	1	SCR, 1/4-20 X 1/2 BHCS DL		
4	86008750	80673	1	KNOB, WITH 1/2-13 F-INSERT		
5	86001170	140054	1	BUSHING, BRZ 3/8-16 X .74 X .50		
6	86279290	89131	1	WELDMENT, FRAME		
7	86001220	140177	1	BRACKET, AXLE HANGER		
8	86091480	14351	1	BAR, HEIGHT ADJUSTMENT		
9	86092030	14353	1	BRKT, HEIGHT ADJ RIGHT		
10	86010910	89094	2	WHEEL, 1-5/8D CUSHION		
11	86259960	89506	2	WHEEL, 1 15/16" x 10" HOOSIER		
12	86010790	87163	1	WASHER, 3/8 SPLIT LOCK PLTD.		
13	86001660	41236	2	HUBCAP, 5/8" SHAFT		
14	86270880	57032	2	NUT, 3/8-16 SERRATED FLG.		
15	86005680	57047	4	NUT, 1/4-20 NYLOCK PLTD.		
16	86080800	62623	1	PLATE, AXLE MOUNTING		
17	86279420	87156	2	WASHER, .75ID X 1.25OD X .125		
18	86000390	67376	1	ROD, .625 X 25.30 CRS		
19	86010740	87090	8	WASHER, 1/4ID X 3/4OD		
20	86010730	87088	3	WASHER, 3/4ID X 1.00 PLTD.		
21	86010660	87025	4	WASHER, 1/4 LOCK EXT. STAR SS		
22	86007740	73362	1	SPRING, EXT .50D X 1.75L X .06W		
23	86006920	70507	1	SCR, 3/8-16 X 3/4 HHCS GR5 PLTD.		
24	86275570	70505	8	SCR, 1/4-20 X 1.0 HHCS PLTD.		

# VACUUM GROUP

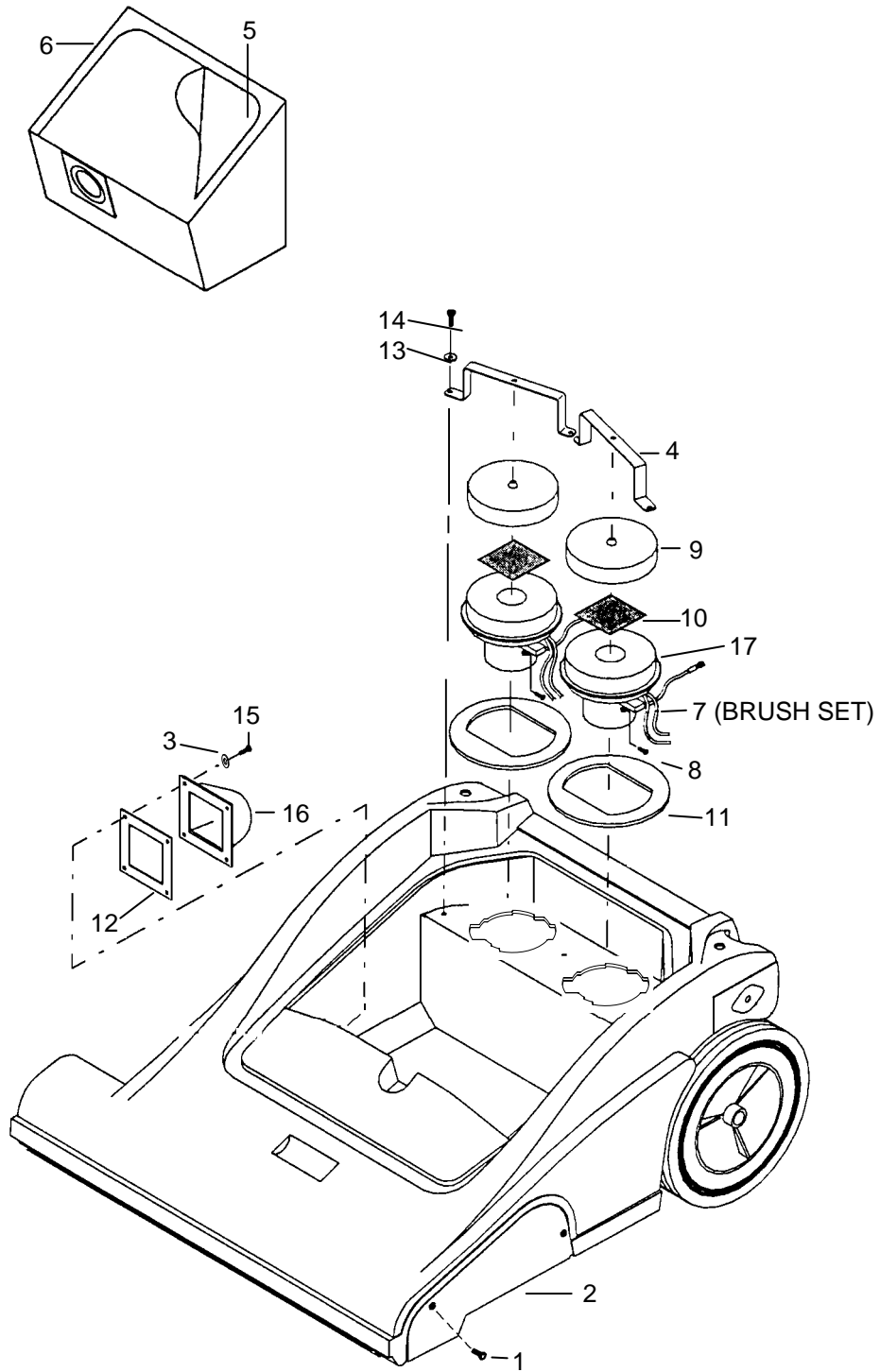

## VACUUM GROUP PARTS LIST

REF	PART NO.	PRV NO.	QTY	DESCRIPTION	SERIAL NO. FROM	NOTES:
1	86276040	70586	5	SCR, 1/4-20 X 3/4 BLK PPHTC		
2	86064180	36185	1	GUARD, BELT		
3	86010650	87018	4	WASHER, #10 X 9/16 OD		
4	86068760	140196	2	BRKT, VAC MOTOR MOUNTING		
5	86215090	140949	2	BAG, PAPER WIDE AREA VAC		
6	86001200	140164	1	BAG, CLOTH U19855		
7	86135320	140687	-	BRUSH SET, 120V VAC		
8	86006770	70323	2	SCR, 10-32 X 1/4 PHTR PLTD.		
9	86003510	34012	2	FILTER, VAC MOTOR		
10	86086800	73461	2	SCREEN, 5/32 .032T 20GA AL 3X3		
11	86237580	35204	2	GASKET, 4.0ID X 5.5OD X .38THK PRN		
12	86006820	35200	1	GASKET, FILTER BAG NECK		
13	86010660	87025	2	WASHER, 1/4 LOCK EXT STAR SS		
14	86275570	70505	2	SCR, 1/4-20 X 1.0 HHCS PLTD.		
15	86006600	70114	4	SCR, #10 X 3/4 POLYFAST		
16	86309510	-	1	DEBRIS CHUTE, CV 71/2		
17	86026850	53783	2	VAC MOTOR, 120V 5.7 1ST		



## HANDLE GROUP PARTS LIST

REF	PART NO.	PRV NO.	QTY	DESCRIPTION	SERIAL NO. FROM	NOTES:
1	86274640	70253	1	SCR, 10-32 X 1.25 PPHMS		
2	86076510	38272	1	HANDLE, MAIN		
3	86268300	88231	1	WIRE, 6" GRN/18 76008 X 76011		
4	86091470	140309	1	BAR ASM, BRUSH SWITCH		
5	86069190	140310	1	BRKT, SWITCH MOUNTING		
6	86198480	27371	4	CLIP, POWER CORD		
7	86309530	-	1	HOLSTER, CV 71/2		
8	86246320	51142	1	LEVER, HANDLE LOCK		
9	86238290	36104	2	GRIP, HANDLE ADJUSTMENT		
10	86005630	57022	1	NUT, 3/8-16 THIN NYLOCK SS		
11	86005710	57105	1	NUT, 1/4-20 HEX W/ STAR WASHER		
12	86008650	80604	1	RING, RUE COLLAR 1/4 PLTD.		
13	86272300	66133	1	PIN, CLEVIS 3/16 X 7/8L		
14	86005020	51184	2	LOCK, HANDLE ADJUSTMENT		
15	86006380	67374	1	ROD, HANDLE ADJ.		
16	86256170	73169	1	STRAIN RELIEF, CORD HOOK		
17	86005050	51254	2	LOCK, HANDLE		
18	86010710	87080	2	WASHER, .5 X 1.25 FLAT PLTD.		
19	86271240	57154	2	NUT, CAP 1/4 DIA RETAINING PLTD.		
20	86007050	70683	4	SCR, 10-32 X 3/8 PHMS SS DL		
21	86006720	70245	2	SCR, 4-40 X 3/4 PHMS PLTD.		
22	86006800	70361	2	SCR, 10-32 X 1/2 PHTR PLTD.		
23	86007100	72093	1	SWITCH, 125VDC SPST N.O.		
24	86007820	73698	2	SPACER, .50D X .28ID X .38L		
25	86255250	73843	1	SPRING, TORSION		
26	86089370	78365	1	TUBE, HANDLE ADJUSTMENT		
27	86010640	87016	5	WASHER, #10 LOCK EXT. STAR SS		
28	86010650	87018	6	WASHER, #10 X 9/16OD		
29	86010690	87068	4	WASHER, 1/8 RIVET BACKUP		
30	86006510	70043	4	SCR, 10-32 X 5/8 PFHMS SS		
31	86271280	57163	2	NUT, 4-40 W/ STAR WASHER		
32	86249500	62839	1	PLATE, SWITCH BOX INSLTR		
33	86146430	51299	1	LEVER, SPRING STEEL		
34	86006810	70363	1	SCR, 10-32 X 3/8 PHTR PLTD.		
35	86007010	70663	1	SCR, 1/4-20 X 3-1/4 HHCS PLTD.		
36	86010660	87025	1	WASHER, 1/4 LOCK EXT STAR SS		
37	86279220	57104	1	NUT, 10-32 W/ STAR WASHER PLTD		

# LID/DECAL GROUP

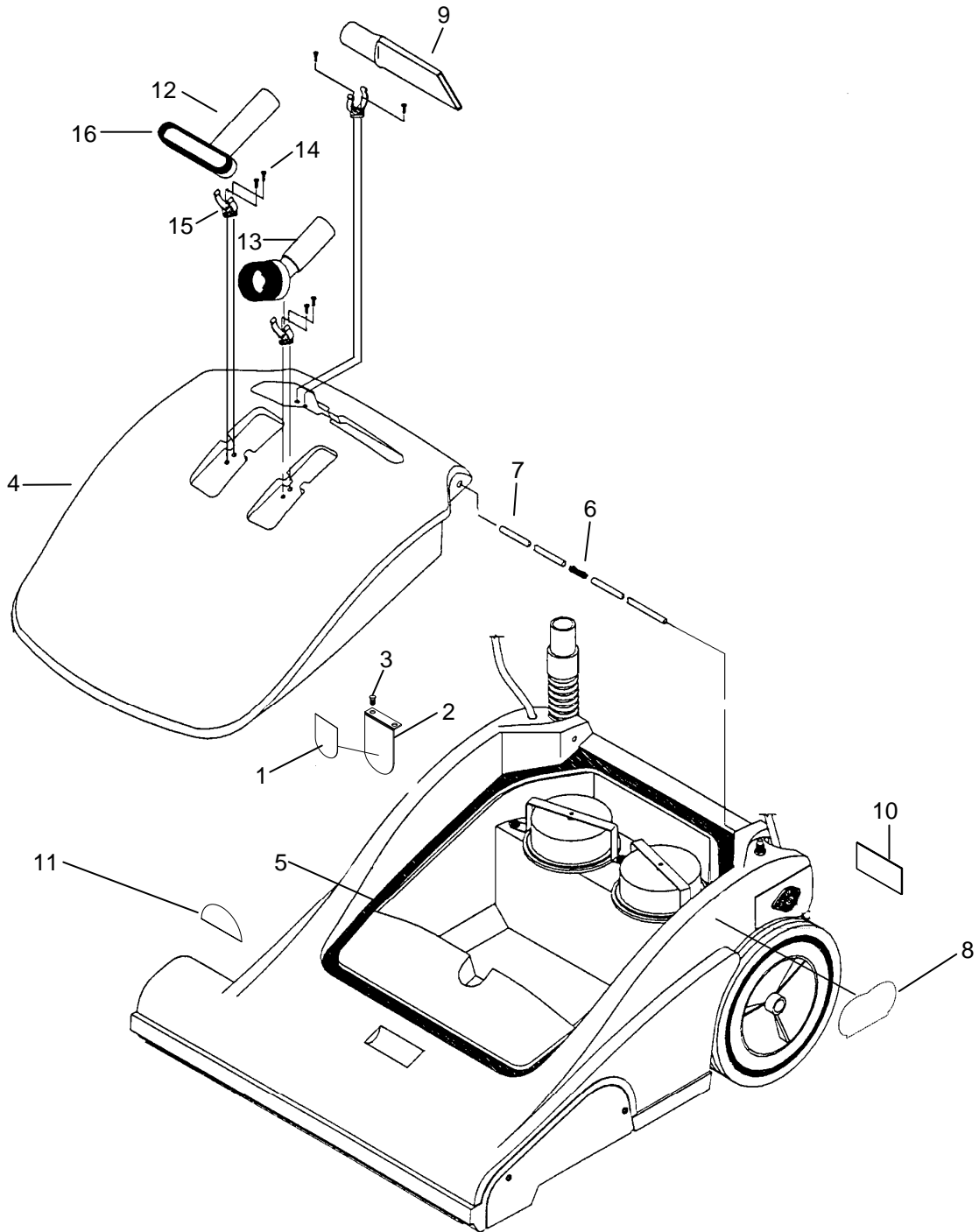

## LID/DECAL GROUP PARTS LIST

REF	PART NO.	PRV NO.	QTY	DESCRIPTION	SERIAL NO. FROM	NOTES:
1	86003780	35171	1	GASKET, ACCESSORY PORT		
2	86234760	27674	1	COVER, ACCESSORY PORT		
3	86006500	70024	2	SCR, #8 X 1/2 SHT METAL SS		
4	86309550	-	1	LID, CV 71/2		
5	86237590	35207	2	GASKET, FOAM 1/2 X 10		
6	86255240	73838	1	SPRING, .24OD X 2.0 COMP		
7	86006290	66285	2	PIN, .250 X .75 CRS		
8	86343430	-	2	LABEL, CV 71/2		
9	86000160	02292	1	TOOL, 11" PLASTIC CREVICE		
10	86246560	50776	1	LABEL, WARNING		
11	86245620	50762	1	LABEL, BRUSH HEIGHT ADJ.		
12	86000080	02084	1	TOOL, 5" UPHOLSTERY		
13	86000070	02083	1	BRUSH, 3" DUST		
14	86274520	70233	6	SCR, #10 X 3/8 PH HI-LO PLTD		
15	86002990	27744	3	CLIP, C 1-1/2 PLASTIC		
16	86283600	02085	2	BRUSH, UPHOLSTERY		

# ELECTRICAL PANEL AND COVER GROUP

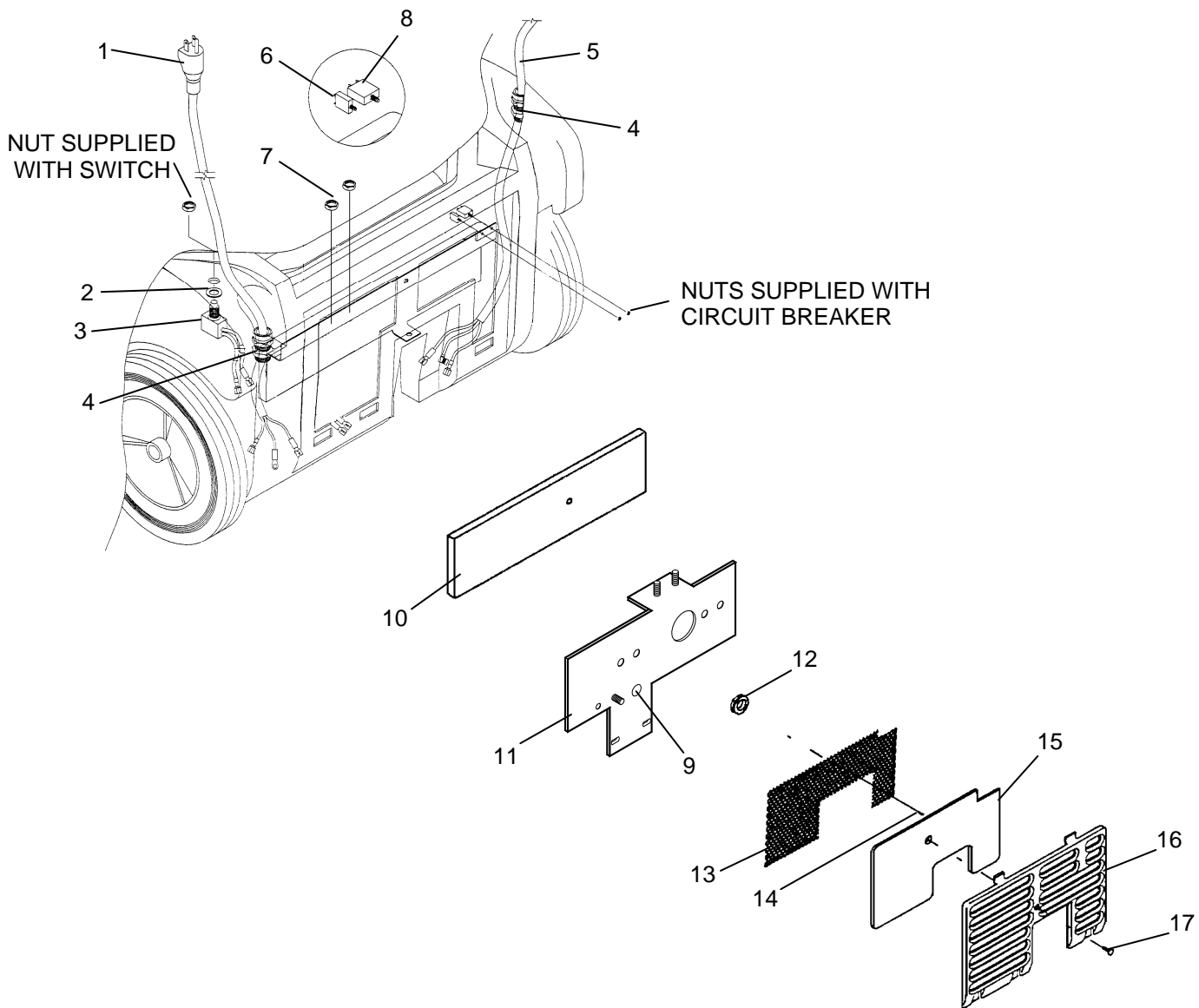

## **ELECTRICAL PANEL & COVER GROUP PARTS LIST**

REF	PART NO.	PRV NO.	QTY	DESCRIPTION	SERIAL NO. FROM	NOTES:
1	86234300	23672	1	CORD ASM, 115V		
2	86279220	87104	1	WASHER, 1/2 EXT. STAR		
3	86261560	880250	1	WIRE ASM, MAIN SWITCH/BREAKER		
4	86005670	57040	2	NUT, 1/2 NPT CONDUIT		
5	86261570	880253	1	WIRE ASM, BRUSH/HANDLE SWITCH		
6	86230120	14313	1	BREAKER, 13A CIRCUIT		
7	86005680	57047	2	NUT, 1/4-20 HEX NYLOCK		
8	86230050	140239	1	BREAKER, 3.0A THERMAL CIR.		
9	86245040	50279	1	LABEL, GROUND SYMBOL		
10	86003550	34310	1	FOAM, SOUND INSULATION		
11	86082750	66323	1	PLATE, ELECTRICAL PANEL		
12	86238400	36125	1	GROMMET, 3/4ID X 1.38OD		
13	86086830	73863	1	SCREEN, EXHAUST		
14	86006500	70024	8	SCR, #8 X 1/2 SHT METAL SS		
15	86236080	34326	1	FILTER, EXHAUST		
16	86063720	27738	1	COVER, REAR		
17	86172770	70610	1	SCR, 1/4-20 X 1.0 BLK THUMB		

## **SUGGESTED SPARE PARTS**

PART NO.	PRV NO.	DESCRIPTION	SERIAL NO. FROM	NOTES:
86001090	11041	BELT, 220 J-6 POLY-V		
86215090	140949	BAGS, PAPER (PKG. OF 10)		
86003510	34012	FILTER, VAC MOTOR		
86236040	34309	FILTER, EXHAUST		
86001200	140164	BAG, CLOTH		
86135260	140211	BRUSH SET, VAC MOTOR		
86135360	14340	BRUSH SET, 53616/53617		