

KNA-S

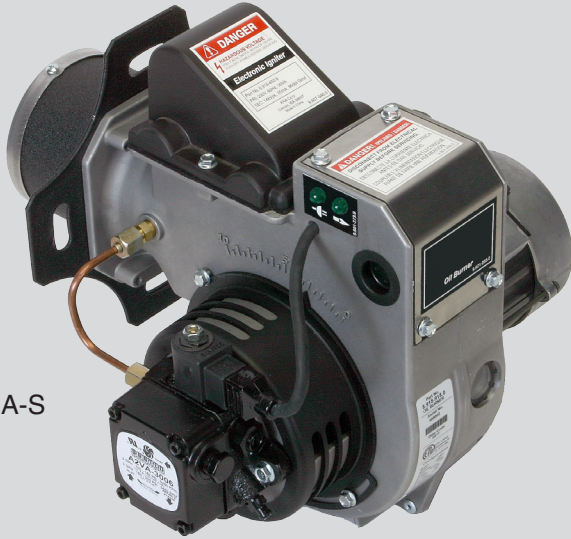

Patent No. D665, 901

KNA Oil Fired Burner



KNA-M / L

KNA
CORPORATION

Operator's Manual



9.801-300.0 rev. 3/14 D

To the Owner:

Thank you for purchasing a KNA burner. Please pay attention to the Safety Warnings contained within this instruction manual. Keep this manual for your records and provide it to your qualified service agency for use in professionally setting up and maintaining your oil burner.

Your KNA burner will provide years of efficient operation, if it is professionally installed and maintained by a qualified service technician. If at any time the burner does not appear to be operating properly, **immediately contact your qualified service agency** for consultation.

We recommend annual inspection/service of your oil heating system by a qualified service agency,

Daily — Check the area in which your burner/equipment is installed. Make sure:

- Air ventilation openings are clean and unobstructed
- Nothing is blocking burner inlet air openings
- No combustible materials are stored near the heating equipment
- There are no signs of oil or water leaking around the burner or equipment.

Weekly

- Check your oil tank level. Always keep your oil tank full, especially during the summer, in order to prevent condensation of moisture on the inside surface of the tank.

Contents

General Information.....	4
Hazard Definitions	4

**Remainder of manual to be used
ONLY BY QUALIFIED SERVICE TECHNICIANS**

Special Requirements	5
General Specifications	5
Inspect/Prepare Installation Site.....	6
Inspect Chimney or Direct Vent System	6
Combustion Air Supply Information	7
Prepare the Burner.....	8
General	8
Mount Burner on Equipment	8
Connect Fuel Lines	9
Fuel Line Installation	9
Fuel Line Valves and Filter	9
Wiring the Burner	10
Burner Packaged with Equipment	10
Burner Installed at Job Site	10
Wiring Connection Diagrams	11-13
Start the Burner and Set Combustion	14
Start-up and Initial Settings	14
Burner Tube, Static Disk, Air Cone, Set-up	15
Set Combustion with Test Instruments	16
Perform Regular Maintenance.....	17
Trained Service Technician's Regular Maintenance	17
Removing Nozzle Line for Service	18
Nozzle Installation	18
Nozzle Replacement	18-19
Check/Adjust Electrodes	19
Blower Wheel Replacement	19
Honeywell R7284U Electronic Oil Primary ...	20-23
Replacement Parts	24-27
Warranty	28

General Information

Hazard Definitions

DANGER Indicates a hazardous situation which, if not avoided, will result in serious injury or death.

WARNING Indicates a hazardous situation which, if not avoided, could result in serious injury or death.

CAUTION Indicates a hazardous situation which, if not avoided, could result in minor or moderate injury.

Within the boundaries of the hazard warning, there will be information presented describing consequences if the warning is not heeded and instructions on how to avoid the hazard.

NOTICE Intended to bring special attention to information, but not related to personal injury or damage.

WARNING Owner's Responsibility

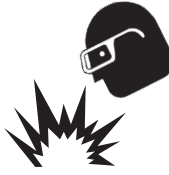

Incorrect installation, adjustment and use of this burner could result in severe personal injury, death, or substantial property damage from fire, carbon monoxide poisoning, soot or explosion.

Contact a professional qualified service agency for the installation, adjustment and service of your oil heating system. This work requires technical training, trade experience, licensing or certification in some states and the proper use of special combustion testing instruments.

Please carefully read and comply with the following instructions:

- Never store or use gasoline or other flammable liquids or vapors near this burner or equipment.
- Never attempt to light the burner/appliance by throwing burning material into the equipment.
- Never attempt to burn any fuel not specified and approved for use in this burner.
- Never restrict the air inlet openings to the burner or the combustion air ventilation openings.

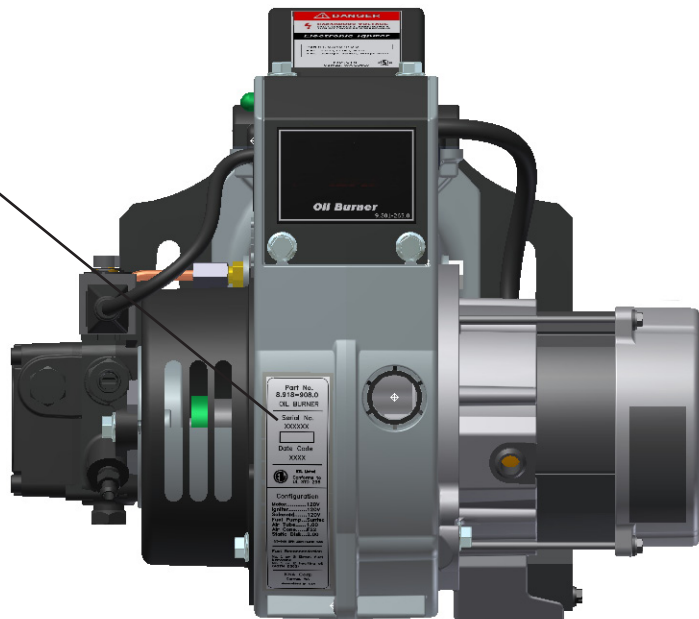
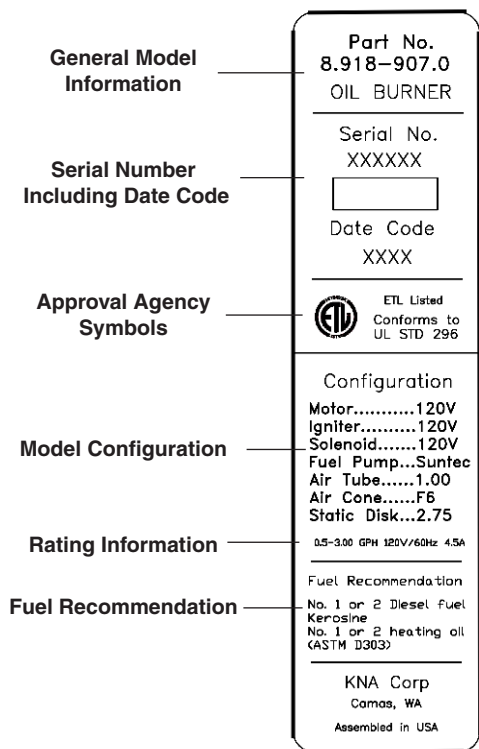

FIGURE 1. BURNER SERIAL PLATE INFORMATION

NOTICE**Special Requirements**

- **The installation of a burner shall be in accordance with the regulation of authorities having jurisdiction.**
- Concealed damage: If you discover damage to the burner or controls during unpacking, notify the carrier at once and file the appropriate claim.
- When contacting KNA for service information, please record the burner serial number (and have available when calling or writing). You will find the serial number on the silver label located on the left rear of the burner. Refer to **Figure 1**.

**WARNING Impaired Burner Performance and Fire Hazard**

DO NOT operate the burner beyond specifications outlined in the following Table 1.

For applications beyond these limits, consult KNA Technical Service at 1-877-283-2412.

General Specification**TABLE 1: BURNER SPECIFICATIONS**

Capacity (Note 1)	Firing rate - 0.75-3.00 GPH "S" Models 1.00-7.00 GPH "M/L" Models Input: Min. - 75,000 Btu Max. - 960,000 Btu
Certification / Approvals	UL certified to comply with ANSI / UL296 & tested to CSA B140.0
Fuels	U.S.: No. 1 or No. 2 heating oil only (ASTM D396). Canada: No.1 stove oil or No. 2 furnace oil only. Bio-diesel fuels must meet ASTM D6751 and petroleum fuels must meet ASTM D396. Bio-diesel fuels are a 5% bio-diesel and 95% fuel oil blend.  CAUTION DO NOT USE GASOLINE, CRANKCASE OIL OR ANY OIL CONTAINING GASOLINE
Electrical	Power Supply: 120 Volts AC, 60 Hz, single phase Operating Load: 5.8 Amps max. Power Supply: 230 Volts, 60 Hz, single phase Operating Load: 2.8 Amps max. Power Supply: 12 Volts DC Operating Load: 11 Amps max.
Motor	Motor: 1/7 Hp, 3450 Rpm, NEMA 48M Frame PSC rotation CCW when facing shaft end Motor: 1/4 Hp, 3450 Rpm, NEMA 48N Frame rotation CCW when facing shaft end Ignition: Continuous duty solid state ignitor
Fuel pump	Outlet pressure - Max 225 psi
Air Tube	1.25" - 3.25"
Dimensions	Model "S" Height (Maximum): 11 inches Width (Maximum): 13 inches Depth: 12-3/8 inches Air Tube Diameter: 3-1/2 inches
Weight	20 Lbs.
Dimensions	Model "M/L" Height (Maximum): 12.5 inches Width (Maximum): 15 inches Depth: 14 inches Air Tube Diameter: 3-1/2 inches
Weight	25 Lbs
Ambient Operating Temperature	+32° F. (0° C) Minimum +115° F. (+46° C.) Maximum (See above warning)

Inspect/Prepare Equipment Site Location

! DANGER Professional Service Required

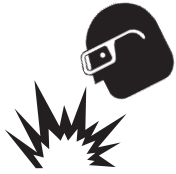

Incorrect installation, adjustment and use of this burner could result in severe personal injury, death or substantial property damage from fire, carbon monoxide poisoning, soot or explosion.

Please read and understand the manual supplied with this equipment. This equipment must be installed, adjusted and put into operation only by a qualified individual or service agency that is:

- Licensed or certified to install and provide technical service to oil heating equipment.
- Experienced with all applicable codes, standards and ordinances.
- Responsible for the correct installation and commission of this equipment.
- Skilled in the adjustment of oil burners using combustion test instruments.

Inspect Flue Pipe

! WARNING Fire, Smoke & Asphyxiation Hazard

- Carefully inspect the exhaust vent system
- Make sure it is properly sized and in good working condition
- Follow the instructions supplied by the equipment manufacturer.
- Regulation by these authorities take precedence over the general instructions provided in this installation manual.

Starting with minimum gph firing rate, the minimum size recommended is 8" flue pipe with 8" x 8" inside chimney, unless specified otherwise by the equipment manufacturer.

1. A flue pipe shall extend at least 3 feet above the highest point at which the flue pipe comes in contact with the roof and not less than 2 feet above the highest roof surface or structure within 10 feet horizontally of the flue pipe. Refer to Figure 2.
2. Any accumulation of soot or debris in the flue piping offsets should be removed.
3. Any obstruction, such as a protruding joint in the flue pipe, should be removed.

Figure 2 – Flue Pipe Design - Above the Roof

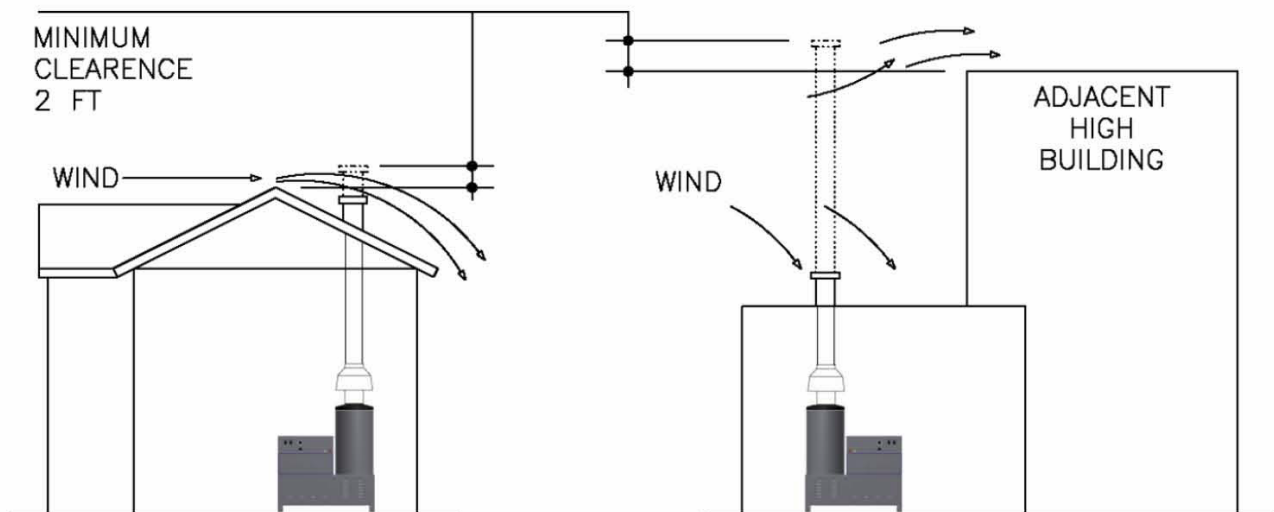

NOTE: Correct flue pipe design is shown by dotted lines. Incorrect flue pipe design, as shown by the solid lines, may result in down-drafts.

Schedule Maintenance Program

The new design of flame retention oil burners is more efficient. One result of increased efficiency, is lower flue gas temperatures. As flue gases pass through the coil, they cool and condense when they reach the dew point (the temperature which air becomes saturated and produces dew). The condensation mixes with the sulfur in the flue gasses to create sulfuric acid. The acid attacks the coil, wrap and connected plumbing causing corrosion, deterioration and blockage of the air passage ways. Eventually this blockage could prevent the exhausting of flue gases.

Therefore, it is strongly recommended that the coil and combustion box be examined on a regularly scheduled maintenance program to prevent and remove any build-up of soot from accumulating.

Combustion Air Supply Information



WARNING

Adequate Combustion and Air Supply Ventilation Required

Failure to provide adequate air supply could seriously affect the burner performance and result in damage to the equipment, asphyxiation, explosion or fire hazards.

- The burner cannot properly burn fuel if it is not supplied with a reliable combustion air source.
- Follow the guidelines from the manufacturer, for locating the equipment in a well ventilated and accessible area, to allow for full combustion efficiency.

Equipment Located In Confined Spaces

All confined spaces should have two (2) permanent openings; one near the top of the enclosure and one near the bottom of the enclosure. Each opening must have a free area of not less than one (1) square inch per 1,000 BTU's per hour of the total input rating of all equipment within the enclosure. The openings should have free access to the building interior, which should have adequate infiltration from the outside.

Exhaust Fans And Other Air-Using Devices

Air openings should be large enough to supply all air-using devices, in addition to the minimum size required for combustion air. If there is any possibility of the equipment room developing a negative pressure you must either pipe combustion air directly to the burner or provide a sealed enclosure for the burner and supply it with its own combustion air supply.

Minimum Chamber Dimensions

Verify that the equipment combustion chamber provides at least the minimum dimensions given in Table 2.

TABLE 2 - CHAMBER DIMENSIONS

Chamber Dimensions (inches)		
Firing Rate (GPH)	Round I.D.	Firing Length
0.75 - 1.25	12	12.0
1.25 - 1.75	13	12.0
1.75 - 2.00	14	14.0
2.00 - 2.25	15	15.0
2.25 - 2.75	16	18.0
2.75 - 3.0	20	20.0
3.0 - 4.0	22	22
4.0 - 5.0	25	25

Prepare the Burner

General

In most cases, the burner is ready to mount to the equipment. There can be situations where the burner needs to be re-configured to perform properly in the equipment. Review the equipment manufacturer's specifications prior to installing to determine if any modification is required to properly configure the burner.

Mount Burner on Equipment

Verify that the air tube installed on the burner provides the correct insertion depth. Refer to *Figure 3*.

The end of the air tube should normally be 1/4" back from the inside wall of the combustion chamber. Never allow the leading edge of the air cone to extend into the chamber, unless otherwise specified by the equipment manufacturer.

Bolt the burner to the equipment using the flange that is provided.

FIGURE 3 - MOUNTING BURNER ON EQUIPMENT

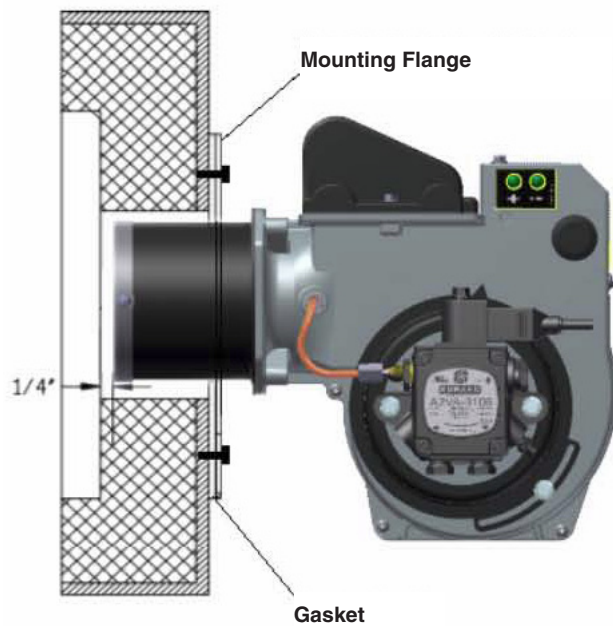

Connect Fuel Lines

WARNING Oil Leak and Fire Hazard

Install the oil tank following applicable standards in the U.S. by referring to the latest edition of NFPA 31 or CSA-B139 & CSA-B140 in Canada, and all authorities having jurisdiction

CAUTION Do Not Use Teflon Tape

Damage to the pump could cause impaired burner operation, oil leakage and appliance soot-up.

- Never use Teflon tape on fuel oil fittings.
- Tape fragments can lodge in fuel line components and fuel unit, damaging the equipment and preventing proper operation.
- Use oil-resistant pipe sealant compounds.

NOTICE To determine the proper fuel line size, refer to the fuel pump manufacturer's instructions provided with the burner. Refer to **Figure 5** or **Figure 6** for typical installation layouts.

The burner is supplied with a single stage fuel pump. Consult the instruction sheet provided with the pump for installation specifications.

When installing a **one-pipe system**, connect the inlet line to the pump inlet. The fuel pump may be installed with gravity feed or lift. The maximum allowable lift for a single pipe installation is 8 ft.

When installing a **two-pipe system**, remove the 1/16" pipe bypass plug from plastic bag attached to fuel unit. Remove the 1/4" plug from the return port. Insert and tighten the bypass plug. Attach return and inlet lines. The return line should terminate approximately 3 to 4" above supply line inlet. Failure to do this may introduce air into the system and could result in loss of prime.

Fuel Line Installation

Route the fuel line to the inlet port of the fuel pump. Use 1/4" ID copper tubing or flexible hose compatible with fuel oil.

Always install fittings and fuel lines in an accessible location and so they do not rub against sharp panels or objects.

Fuel Line Valves and Filter

WARNING Do Not Install By-pass Plug with 1-Pipe System

Failure to comply could cause immediate pump seal failure, pressurized oil leakage and the potential for a fire and injury hazard.

The burner is shipped without the by-pass plug installed.

Install the by-pass plug in two-pipe oil supply systems ONLY.

CAUTION Oil Supply Pressure Control Required

Damage to the filter or pump seals could cause oil leakage and a fire hazard.

- When installing a fuel supply tank above the burner, the oil supply inlet pressure cannot exceed 3 psig.
- Insure that a pressure limiting device is installed in accordance with the latest edition of NFPA 31.
- Do NOT install valves in the return line.

Install a high quality, oil duty rated, fusible handle design shutoff valve on the oil supply line close to the fuel tank to provide easy access to the inline fuel filter.

Install a fuel oil filter between the fuel pump and oil tank with a filtration rating of 50 microns or less.

Fuel Supply Level With Or Above Burner

The burner may be equipped with a single-stage fuel unit for these installations. Connect the fuel supply to the burner with a single supply line if you want a one-pipe system (making sure bypass plug is NOT installed in the fuel unit.) Manual bleeding of the fuel unit is required on initial start-up. If connecting a two-pipe fuel supply, install the fuel unit bypass plug.

Fuel Supply Below The Level Of The Burner

When the fuel supply is below the level of the burner, a two-pipe supply system is required. Consult the fuel pump manufacturer's specifications for lift and vacuum capability.

Fuel Line Installation

- A continuous length of fuel line is recommended. Proper attachment to fuel pump with compression fitting or clamps is recommended to avoid suction leaks.
- Always install fittings in accessible locations. Proper routing of fuel lines is required to prevent air cavitation and vibration.

Wiring the Burner



DANGER

Electrical Shock Hazard



Electrical shock can cause severe personal injury or death. Disconnect electrical power before installing or servicing the burner.

- Provide ground wiring to the burner, metal control enclosures and accessories. This may also be required to aid proper control system operation.)
- Perform all wiring in compliance with the National Electrical Code ANSI/NFPA 70 (Canada CSA C22.1)

Burner packaged with equipment

Refer to equipment manufacturer's wiring diagram for electrical connections.

Burner installed at job site

Refer to **Figure 7a-7f** for typical burner wiring.

Refer to equipment manufacturer's wiring diagram prior to connecting the burner wiring. All wiring must be in accordance with the latest revision of National Electric Code NFPA 70 and all local codes and regulations. In Canada, all wiring is to be in accordance with the Canadian Electrical Code, Part 1.

FIGURE 5 — GRAVITY FEED TANK SYSTEM

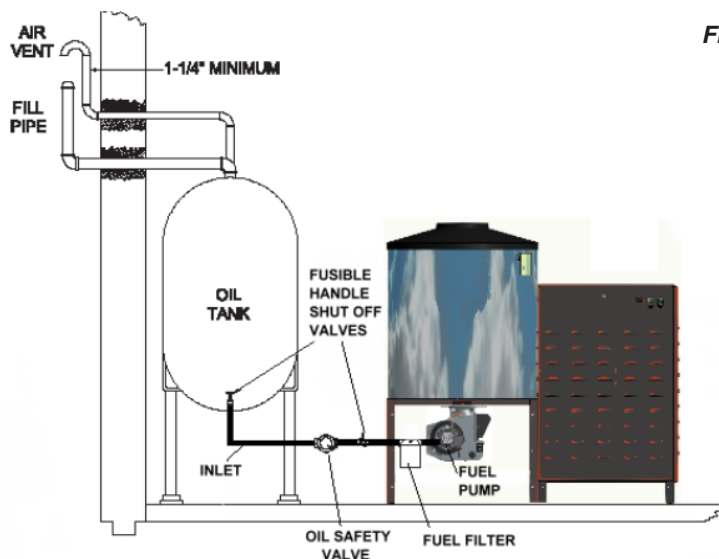
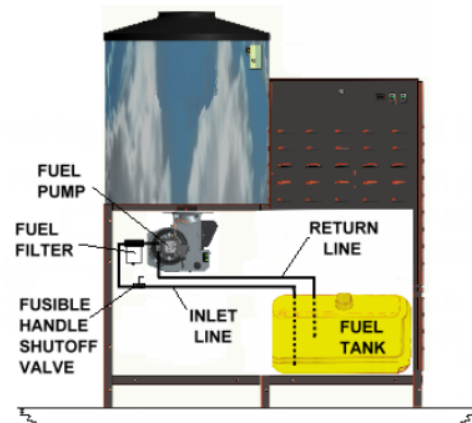

FIGURE 6 — SUCTION FEED TANK - LIFT SYSTEM



Wiring Connections Diagram



WARNING Explosion, Fire, Scald and Burn Hazard

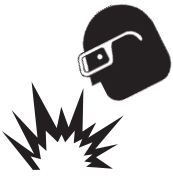

All heating equipment must have HIGH LIMIT protection to interrupt electrical power and shutdown the burner if operating or safety controls fail and cause a runaway condition.

- Follow the equipment manufacturer's wiring diagrams and note all required safety controls.
- Typical safety controls include high temperature or pressure limits, low water cutoffs, pressure relief valves and blocked flue sensing switches.
- Verify all limit and safety controls are installed and functioning correctly, as specified by the manufacturer, applicable safety standards, codes and all authorities having jurisdiction.
- Ensure that the equipment is free of oil and oil vapor before starting or resetting the burner.

Typical connections to the burner control terminal are shown in Figures 7a-7f.

Refer to the equipment manufacturer's wiring diagram prior to connecting the burner wiring. All wiring must be in accordance with the latest revision of National Electric Code NFPA 70 and all local codes and regulations.

FIGURE 7a
115V WIRING DIAGRAM WITH 115V SOLENOID COIL

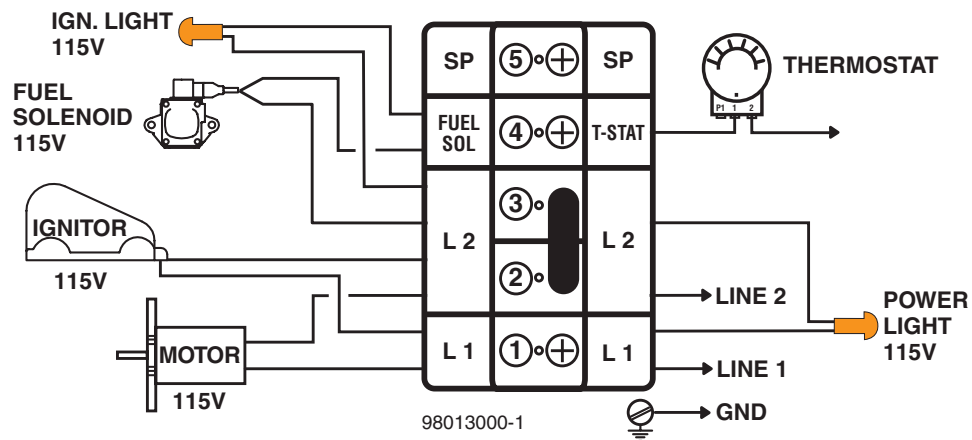

Wiring Connection Diagrams

FIGURE 7b - 115V WIRING DIAGRAM WITH 24V SOLENOID COIL

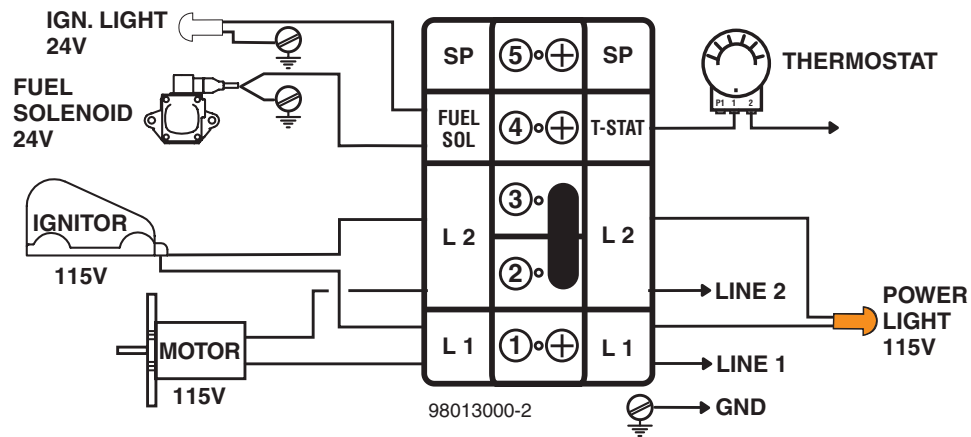

FIGURE 7c - 230V WIRING DIAGRAM WITH 230V SOLENOID COIL

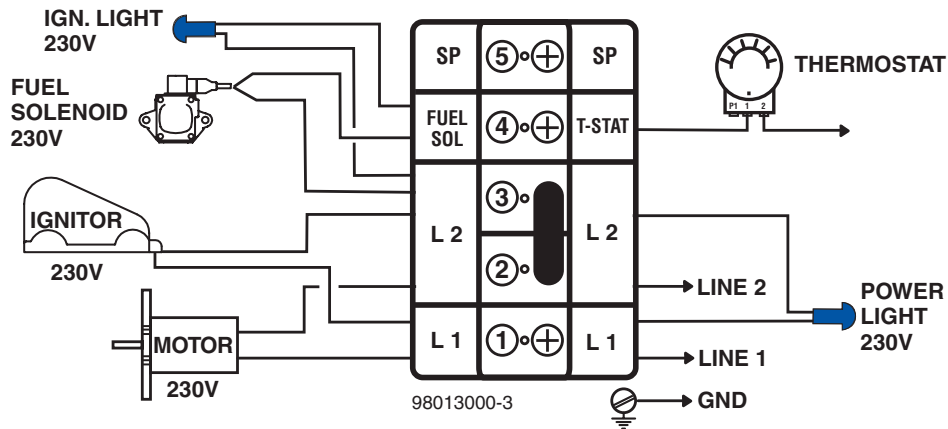
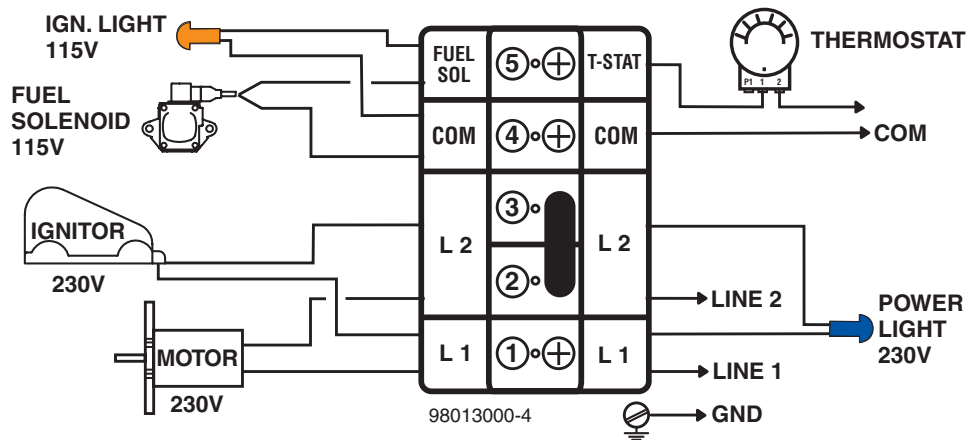

FIGURE 7d - 230V WIRING DIAGRAM WITH 115V SOLENOID COIL



Wiring Connection Diagrams (cont.)

FIGURE 7e - 230V WIRING DIAGRAM WITH 24V SOLENOID COIL

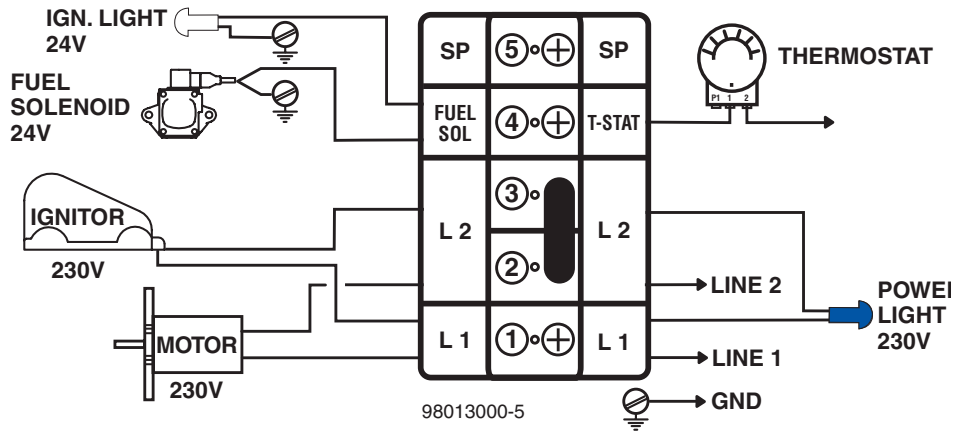

FIGURE 7f - 12VDC WIRING DIAGRAM WITH 12VDC SOLENOID COIL

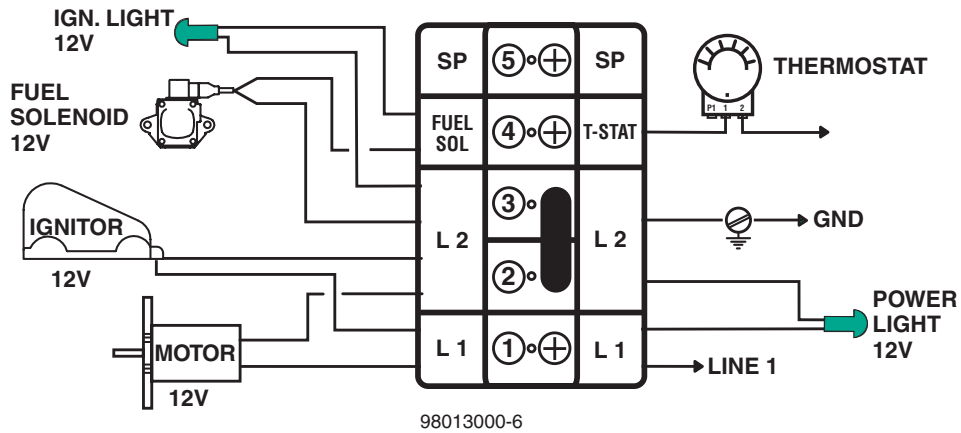

FIGURE 7g - 115V WIRING DIAGRAM WITH PRIMARY CONTROL

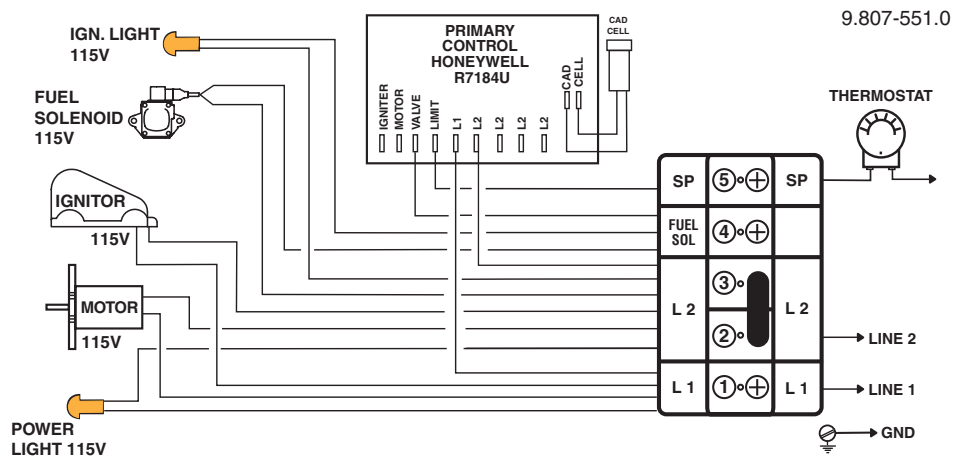
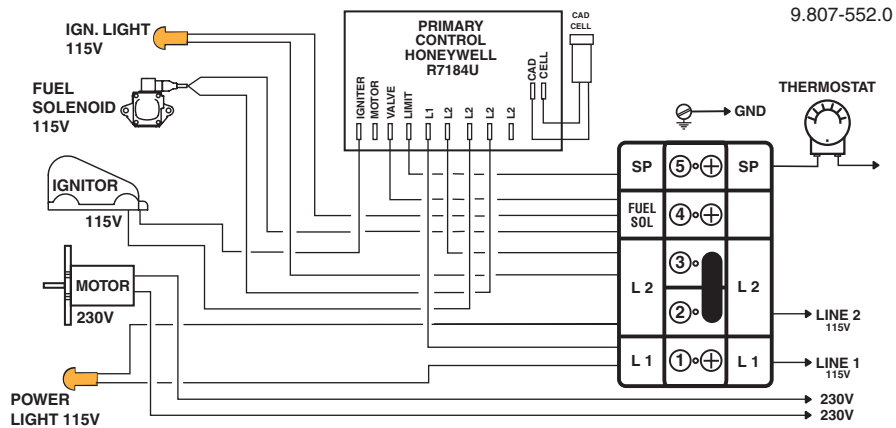

FIGURE 7h - 230V MOTOR WIRING DIAGRAM WITH 115V PRIMARY CONTROL



Start the Burner and Set Combustion

Start-up and Initial Settings

1. Open the shutoff valves in the oil supply line to the burner.
2. Adjust air band pointer to the value specified by the equipment manufacturer. If the equipment manufacturer values are not available, refer to Figure 8. Calibrated test instruments must be used for the final air and fuel adjustment.
3. Adjust the thermostat to call for heat.
4. Turn the burner switch to the "ON" position to start the burner.
5. Bleed any air from the fuel pump as soon as the burner motor begins rotating.
6. Sample exhaust air with Bararach smoke tester to obtain 0-1 combustion efficiency. Adjust air band and fuel pressure if necessary to obtain best results.

**FIGURE 8
AIR BAND & FUEL
PRESSURE ADJUSTMENT**

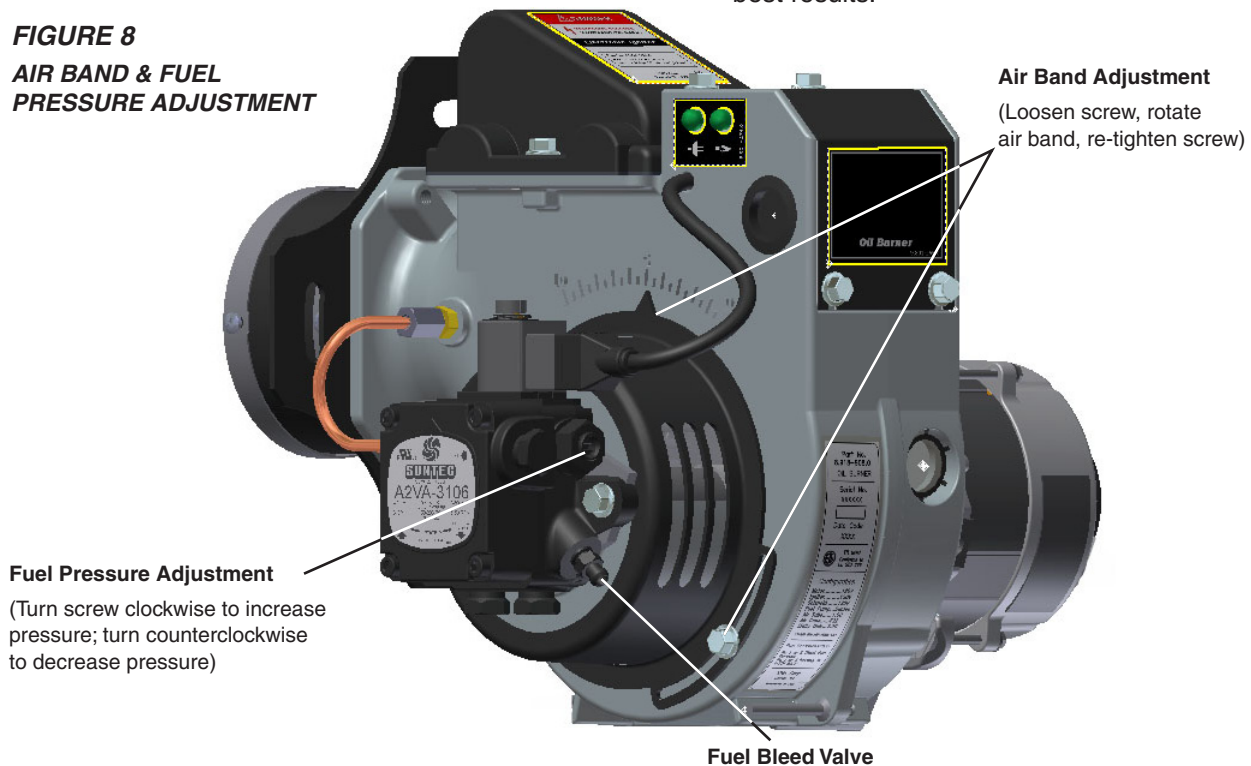

TABLE 3a
KNA BURNER WITH 1.0" AIR TUBE LENGTH

KNA Air Tube, Air Cone & Static Disk Combinations		
Air Tube Length	Air Cone	GPH Rating
1.0	F4	.75 - 1.25
1.0	F6	1.25 - 1.75
1.0	F12	1.75 - 2.00
1.0	F22	2.00 - 2.25
1.0	F22	2.25 - 2.75
1.0	F22	2.75 - 3.50
1.0	F310	3.50 - 5.50

TABLE 3b
KNA BURNER WITH 3.0" AIR TUBE LENGTH

KNA Air Tube, Air Cone & Static Disk Combinations		
Air Tube Length	Air Cone	GPH Rating
3.0	F4	.75 - 1.25
3.0	F6	1.25 - 1.75
3.0	F12	1.75 - 2.00
3.0	F22	2.00 - 2.25
3.0	F22	2.25 - 2.75
3.0	F22	2.75 - 3.50
3.0	F310	3.5 - 5.50

NOTICE

Use factory-set or manufacturer's recommended Air Tube, Air Cone, Static Disk settings for "Starting the Burner and Setting Combustion". The table settings above are provided for reference purposes and represent a general range of rates and settings. Individual equipment, vents and field conditions will impact the overall burner set-up required for satisfactory combustion performance.

 **CAUTION** *Oil Burning Equipment shall be connected to flues having sufficient draft at all times to ensure safe and proper operation of burner.*

Set Combustion with Test Instruments

1. Allow the burner to run for approximately 5 to 10 minutes.
2. Set the stack or over-fire draft to the level specified by the equipment manufacturer.
3. Follow these five steps to properly adjust the burner:

Step 1: Adjust the air band/fuel pressure until a trace of smoke is achieved.

Step 2: At the trace of smoke level, measure the CO₂ (or O₂). This is the vital reference point for further adjustments. Example 13.5% CO₂ (2.6% O₂).

Step 3: Increase the air to reduce the CO₂ by 1.5 to 2 percentage points. (O₂ will be increased by approximately 2.0 to 2.7 percentage points.) Example: Reduce CO₂ from 13.5% to 11.5% (2.6% to 5.3% O₂).

Step 4: Recheck smoke level. It should be zero.

This procedure provides a margin of reserve air to accommodate variable conditions. If the draft level has changed, recheck the smoke and CO₂ levels and **readjust burner if necessary**.

Step 5: Once the combustion has been set, tighten the air band locking screw, see Figure 8.

4. Start and stop the burner several times to ensure satisfactory operation. Test all other equipment safety controls to verify that they function according to the manufacturer's specifications.

Perform Regular Maintenance

Regular Maintenance to be performed by trained service technicians

WARNING

Annual Professional Service Required



Tampering with or making incorrect adjustments could lead to equipment malfunction and result in asphyxiation, explosion or fire.

- DO NOT TAMPER WITH THE UNIT OR CONTROLS — CALL YOUR QUALIFIED SERVICE TECHNICIAN OR SERVICEMAN
- To ensure continued reliable operation, a qualified service technician must service this burner assembly.
- More frequent service intervals may be required in dusty or adverse environments.
- Operation and adjustment of the burner requires technical training and skillful use of combustion test instruments and other test equipment.

The following guidelines are provided for routine maintenance. It is good practice to keep a record of the service performed and the combustion test results.

- Replace the oil supply line filter. The line filter cartridge must be replaced to avoid contamination of the fuel pump and nozzle.
- Inspect the oil supply system. All fittings should be tight and leak-free. The supply lines should be free of water, sludge and other restrictions.
- Remove and clean the pump strainer if applicable.
- Replace the used nozzle with a new nozzle that conforms to the appliance manufacturer's specifications.
- Clean and inspect the electrodes for damage. Replace any that are cracked or chipped.
- Check electrode tip settings. Replace electrodes if tips are rounded.
- Inspect the igniter spring contacts.
- Inspect all gaskets. Replace any that are damaged or fail to seal adequately.
- Clean the blower fan, air band, air cone of any lint or foreign material.
- Use a clean, soft cloth with a degreaser to clean any accumulated soot or oil stains from the sight glass viewing window.
- Check motor current. The amp draw should not exceed the nameplate rating.
- Check all wiring for secure connections or insulation breaks.
- Check the pump pressure and cutoff function.
- Check the ignition system for proper operation.
- Inspect and clear the vent system and flue pipe of any soot accumulation or other restriction.
- Check the burner performance. Refer to the section "Set combustion with test instruments".

Removing the Nozzle for Service

(Reference the Replacement Parts Diagram)

WARNING

Correct Nozzle and Flow Rate Required



Incorrect nozzles and flow rates could result in impaired combustion, under firing, over firing, sooting, puff-back of hot gasses, smoke and potential fire or asphyxiation hazards.

Use only nozzles having the brand, flow rate (gph), spray angle and pattern specified by the equipment manufacturer.

Follow the equipment manufacturer's specifications for the required pump outlet pressure for the nozzle since this affects the flow rate.

- Nozzle manufacturers calibrate nozzle flow rates at 100 psig.
- This burner utilizes pressures higher than 100 psig, so the actual nozzle flow rate will be greater than the gph stamped on the nozzle body. (Example: A 1.00 gph nozzle @ 140 psig = 1.18 gph).

For typical nozzle flow rates at various pressures, see Table 4.

1. Before proceeding, turn off the main power switch to the burner.
2. Disconnect the copper connector tube assembly from the nipple of the gun assembly.
3. Remove the nipple and brass plug from the gun assembly.
4. Remove the two screws securing the igniter to the fan housing and lift igniter free of the housing.
5. Slide gun assembly free and clear of the fan housing.
6. Remove nozzle from gun assembly. Be careful not to damage the electrodes or insulators while handling.

Nozzle Installation

Perform the following steps when replacing a nozzle.

CAUTION

Protect Nozzle from Damage
A damaged nozzle could cause impaired combustion, sooting, puffback of hot gases, smoke, oil leakage and potential fire or asphyxiation hazards.

- Use care when handling, removing and installing oil nozzles.
- Carefully follow the guidelines provided in this section.

1. Remove the gun holder assembly to gain access to the nozzle (Figure 9).
2. Use a 3/4" open-end wrench to remove the nozzle adapter from the gun holder.
3. Do not squeeze the electrodes when handling the gun holder assembly. Excessive force could change the electrode tip settings or damage the ceramic electrode insulators.

TABLE 4 - NOZZLE FLOW RATE BY SIZE

Nozzle flow rate U.S. Gallons per hour of No. 2 fuel oil when pump pressure (psig) is:					
Nozzle Size (rated at 100 psig)	125 psi	140 psi	150 psi	175 psi	200 psi
0.75	0.84	0.89	0.92	0.99	1.06
1.00	1.12	1.18	1.23	1.32	1.41
1.10	1.23	1.30	1.35	1.46	1.56
1.20	1.34	1.42	1.47	1.59	1.70
1.25	1.39	1.48	1.53	1.65	1.77
1.35	1.51	1.60	1.65	1.79	1.91
1.50	1.68	1.77	1.84	1.98	2.12
1.75	1.96	2.07	2.14	2.32	2.47
2.00	2.24	2.37	2.45	2.65	2.83
2.25	2.52	2.66	2.76	2.98	3.18
2.50	2.80	2.96	3.06	3.31	3.54
2.75	3.07	3.25	3.37	3.64	3.89
3.00	3.35	3.55	3.67	3.97	4.24
3.25	3.63	3.85	3.98	4.30	4.60
3.50	3.91	4.14	4.29	4.63	4.95
4.00	4.47	4.73	4.90	5.29	5.66
4.50	5.03	5.32	5.51	5.95	6.36

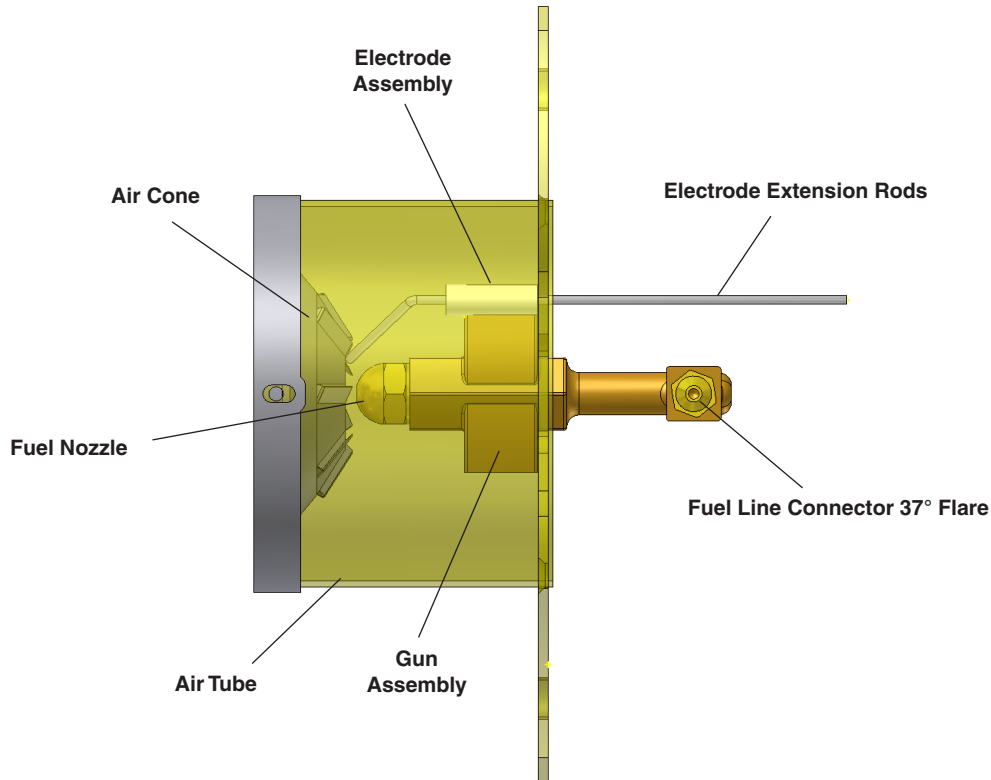
FIGURE 9. - GUN ASSEMBLY/AIR TUBE

4. Use a 5/8" open-end wrench to carefully remove the existing nozzle.
5. Inspect the gun assembly before installing the new nozzle. If it is grooved or scratched on the sealing surface, replace the gun holder assembly. If the surface is damaged, oil could leak at the sealing surface causing serious combustion problems.
6. Protect the fuel nozzle and strainer when installing. If the orifice gets dirt in it or is scratched, the nozzle will not function properly.
7. To install a new nozzle, insert the nozzle into the gun and secure finger tight. Finish tightening with a 5/8" socket wrench to 8.3 ft. lbs. Use care to avoid bending the air cone, and electrodes.
8. Do not over tighten the nozzle when installing. This will cause deep grooves in the gun, and prevent a seal when a new nozzle is installed.
9. Carefully check and realign the electrode tips after replacing a nozzle to ensure the electrode settings comply with Figure 10.
10. If the air cone was removed when replacing the nozzle, carefully reconnect the air cone to the air tube.

Check / Adjust Electrodes

Check the electrode tip settings as shown in *Figure 10*. If necessary, carefully bend the tips with pliers to the correct setting

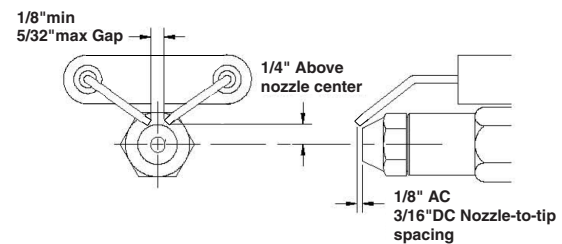
FIGURE 10. - ELECTRODE TIP GAP AND SPACING

Blower Wheel Replacement

For installation or replacement of a blower wheel, insure that there is a space between the blower wheel and the motor face of 1/4". Refer to *Figure 11*.

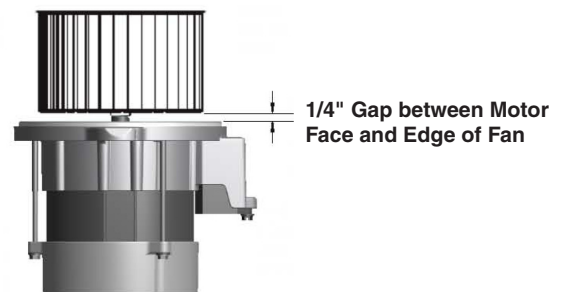
FIGURE 11. - BLOWER WHEEL ASSEMBLY

Honeywell

R7284U Electronic Oil Primary

Application

The R7284U Electronic Oil Primary is a line voltage, safety rated, interrupted and intermittent ignition oil primary control for oil fired burners.

The R7284U used with a cad cell flame sensor operates the oil burner, spark igniter and oil valve.

Features

User Interface

There are two user interfaces: basic and advanced. Both interfaces consist of three buttons: ▲, ▼ and "i".

The advanced interface has a two-line display used to configure device parameters, retrieve diagnostic information and display system status.

The basic interface has a single LED used to display error codes and system status.

In general, the "i" button cycles through the display options and acts as an "enter" key (in set-up modes).

Limited Recycle

This feature limits the number of recycle trials (for each call for heat) to a maximum of three trials. If the flame is lost three times and does not successfully satisfy a call for heat, the R7284 locks out.

Disable Function

Pressing and holding the "i" button will disable all control functions until 3 seconds after the button is released.

Lockout Modes

The R7284 has three types of lockout modes that are entered when an error is encountered.

Disable Function

Pressing and holding the "i" button will disable all control functions until 3 seconds after the button is released.

Lockout Modes

The R7284 has three types of lockout modes that are entered when an error is encountered.

- **Soft Lockout:** Caused by a temporary internal error such as low voltage. The control recovers automatically after the error is no longer detected.
- **Hard Lockout:** Caused by a failure internal to the control or by a system fault such as flame out of sequence. A Hard Lockout will result in a no heat condition. To reset from a Hard Lockout, press and hold the "i" button for 2 seconds.

- **Restricted Lockout:** Caused by a number of consecutive hard lockouts on the same heat cycle. To reset from a Restricted Lockout, press and hold the "i" button for ten seconds.

Cad Cell Resistance

Cad cell resistance can be checked without using an ohm meter.

Basic Interface:

Press and release the "i" button. The resulting flashes indicate the resistance. See Table 6.

Advanced Interface:

The cad cell resistance is shown on the display.

Specifications

Timing:

Valve-on Delay: 0-30 seconds

Burner Off Delay: 0-8 seconds

Lockout: 15, 30 or 45 seconds

Recycle: 60 seconds (fixed)

Ignition Carryover: 10 seconds (fixed)

Electrical Ratings:

Inputs:

Voltage: 102 to 132 Vac. 120 Vac nominal

Current: 0.5A plus burner motor, valve and igniter loads.

Frequency: 60 HZ

Outputs:

Relay Contacts:

Burner: 120 Vac, 10 full load amperes (FLA),
60 locked rotor amperes (LRA)

Valve: 120 Vac, 1A

Igniter: 120 Vac, 3A

Low Voltage Shutdown: 80 Vac

Environmental Ratings:

Operating/Shipping Temperature: -40°F to
+150°F (-40°C to +66°C).

Display text may not be visible below -4°F (-20°C)

Humidity: 0% to 95% relative humidity at 104°F
(40°C) noncondensing.

Pressing "i" during any of the Ignition Time screens moves to the Cycle Count screen below.

187432 BURNER CYCLES	Total burner cycles
8768 CYCLES SINCE BASELINE	Burner cycles since last service (baseline reset).
5 RECYCLES SINCE BASELINE	Flame losses since last service (baseline reset).
2 LOCKOUTS SINCE BASELINE	Ignition failures since last service (baseline reset).

The next press goes back to the View History screen where the user can exit to the home screen or loop back through the performance history again.

Error History Screens

For all Error History screens, pressing "i" returns to the Normal Screen.

ERROR HISTORY
START

From the home screen, press the up button to display most recent error.

ERROR 1	NO IGNITION	ON LAST CYCLE
---------	-------------	---------------

Press the up button again to proceed to the next most recent error or the down button to return to the previous error screen.

ERROR 2	EXCEEDED MAX CYCLES	5 CYCLES ABO
---------	------------------------	--------------

These three screens transition every 3 sec.

If no more errors are logged, the display shows "error History End."

Basic User Interface

The basic user interface consists of 3 buttons and an LED. Simple diagnostic information can be obtained through the interaction of the buttons and LED.

R7284 Status (Basic Interface)

Table 5. LED Codes

Description	LED Code
Standby	Pulse (1/4 sec. ON. 4 sec OFF)
Call for Heat	Heartbeat (1/2sec. bright, 1/2 sec dim)
Flame Proven	On solid
Recycle	2 sec. ON, 2 sec OFF flashing
Lockout	1/2 sec. ON, 1/2 sec. OFF flashing
Interrupt	OFF
"i" Button	Flame Strength Indication
Up Button	Most recent error
Down Button	Next most recent error

R7284 Flame Strength (Basic Interface)

During normal operation and when the R7284 is in the running state, the LED will show CAD cell resistance. See Table 6.

Table 6. Flame Strength Indication

Flame Strength Indication	No. of 1/2 sec Flashes
Cad Cell less than 400 W	1
400 W < Cad Cell < 800 W	2
800 W < Cad Cell < 1600 W	3
1600 W < Cad Cell < 6100 W	4
Cad Cell > 6100 W	None

Error History (Basic Interface)

The last two errors are available for display on the LED:

- Pressing the UP arrow button displays the most recent error
- Pressing the Down arrow button displays the next most recent error.

Once the up or down arrow is pushed, the LED will display the most recent or next most recent alarm by blinking the error code. See Table 4.

R7284 Error Codes

(Basic Interface)

Table 7. Error Codes

Error Codes	No. of 1/4 sec Flashes
No Ignition / Late ignition	1
Max flame losses / CAD Cell high while running	2
Flame out of sequence	3
Low Voltage / EnviraCOM™ error	4
Internal Error	5

Troubleshooting and Maintenance**NOTICE****IMPORTANT**

Due to the potential hazard of line voltage, only a trained, experienced service technician should perform troubleshooting procedures.

This control contains no field-servicable parts. DO NOT attempt to take it apart. Replace entire control if operation is not as described.

To completely troubleshoot an oil burner installation, check the burner and oil primary control for proper operation and condition.

Cad Cell Resistance Check

For proper operation, it is important that the Cad cell resistance is below 1600 ohms. On the basic model with LED interface, during a normal call for heat, once the control has entered the Run mode, press and release the "i" button.

On the advanced model with display, follow the screen diagnostic procedure to read the Cad cell resistance.

Preliminary Steps

1. Check wiring connection and power supply.
2. Make sure power is on to controls.
3. Make sure limit control is closed.
4. Check contacts between igniter and the electrodes.
5. Check the oil pump pressure.
6. Check the piping to the oil tank.
7. Check the oil nozzle, oil supply and oil filter.

Replacement Parts KNA Burner "S"

For best performance specify genuine KNA replacement parts

Models

8.918-901.0	8.918-902.0
8.918-903.0	8.918-904.0
8.918-905.0	8.918-906.0
8.918-907.0	8.918-908.0
8.918-909.0	8.918-910.0
8.918-911.0	8.918-912.0
8.918-913.0	8.918-914.0
8.918-915.0	8.918-916.0
8.918-917.0	8.918-918.0
8.918-919.0	8.918-920.0
8.920-547.0	

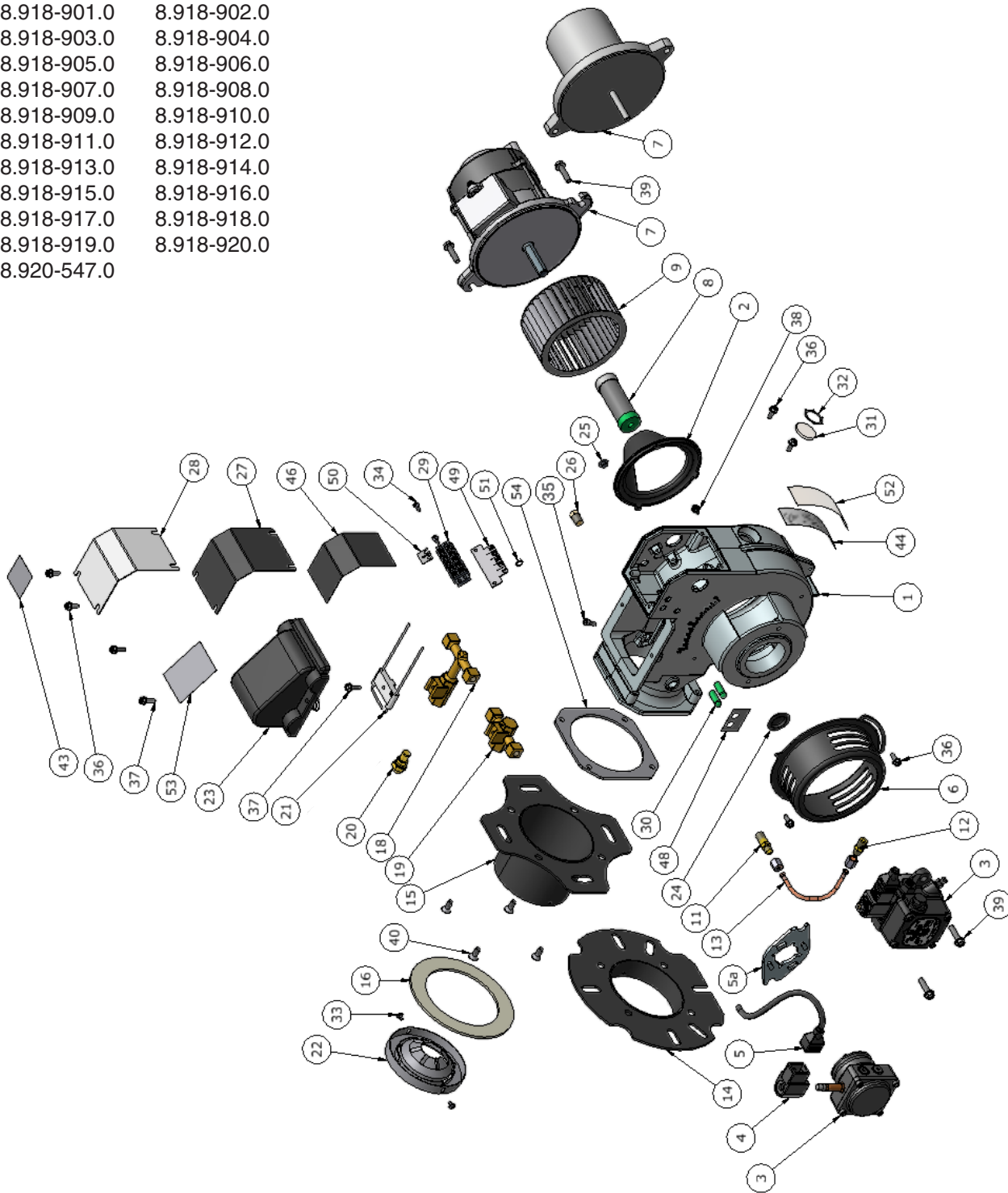

Replacement Parts KNA Burner "S"

For best performance specify genuine KNA replacement parts

Item #	Part #	Description	Qty	Item #	Part #	Description	Qty
1	8.919-050.0	BURNER HOUSING ASSEMBLY	1	25	8.750-830.0	PLUG, HOLE 0.285 PLASTIC	1
2	8.751-160.0	AIR GUIDE	1	26	8.751-134.0	PLUG, 1/8" NPT x HEX SHOULDER	1
3	8.700-758.0	FUEL PUMP, SUNTEC A2VA-3106 12-24V SOL	1	27	8.918-454.0	GASKET, JUNCTION BOX	1
3	8.700-759.0	FUEL PUMP, SUNTEC A2VA-3106 120V SOL	1	28	8.750-542.0	COVER, JUNCTION BOX	1
3	8.700-760.0	FUEL PUMP, SUNTEC A2VA-3106 230V SOL	1	29	8.750-116.0	BLOCK, TERMINAL, 5 POLE	1
3	8.753-000.0	FUEL PUMP, DANFOSS 071N1298	1	30	8.750-817.0	LIGHT, INDICATOR, GREEN 14V	2
4	8.750-762.0	COIL, SOLENOID DANFOSS 230V	1	30	8.750-818.0	LIGHT, INDICATOR, GREEN 28V	1
4	8.750-763.0	COIL, SOLENOID DANFOSS 115V	1	30	8.750-819.0	LIGHT, INDICATOR, GREEN 125V	1
4	8.750-764.0	COIL, SOLENOID DANFOSS 12-24V	1	30	8.750-820.0	LIGHT, INDICATOR, GREEN 250V	1
5	8.750-765.0	CABLE, SOLENOID COIL, DANFOSS	1	31	8.750-784.0	SITE GLASS	1
5a	8.750-783.0	MOUNTING KIT, FLANGE/HUB, DANFOSS	1	32	8.750-785.0	RING, PUSH ON INTERNAL, 1305-112	1
6	8.750-541.0	AIR BAND	1	33	8.733-001.0	SCREW, 8 x 1/4" HI LOW THREAD CUT, PPH	2
7	8.750-517.0	MOTOR, 1/6 HP 115V 60Hz	1	34	8.718-762.0	SCREW, 8-32 X 1/2", M PH RDH PL	2
7	8.750-518.0	MOTOR, 1/6 HP 230V 60Hz	1	35	9.802-745.0	Screw, 10/32 x 1/2" SHCS	1
7	8.751-074.0	MOTOR, 1/7 HP 12VDC AMETEK	1	36	8.718-810.0	SCREW, 10/32 x 1/2", WHIZ LOC FLANGE	6
8	8.750-543.0	COUPLING, FLEX, 1/2" x 5/16"	1	37	8.750-770.0	SCREW, 10/32 x 5/8", WHIZ LOC FLANGE	3
8	8.751-073.0	COUPLING, FLEX, 5/16" x 5/16"	1	38	8.750-816.0	SCREW, 10/32 X 1/4" GROUNDING	1
9	8.750-520.0	FAN, 4.53" X 2.42", 1/2" BORE, F115-62S	1	39	8.750-768.0	SCREW, 1/4-20 x 1", WHIZ LOC FLANGE	4
9	8.751-072.0	FAN, 4.53" x 2.42" x .313 BORE, F115-625	1	40	8.750-771.0	SCREW, 1/4-20 X 1/2", PHIL FHMS	4
11	8.750-547.0	CONNECTOR, 37 DEG FLARE X 1/8" NPT, LONG	1	42	—	LABEL, BRAND NAME	1
12	8.750-545.0	CONNECTOR, 37 DEG FLARE X 1/8" NPT	1	43	9.801-268.0	LABEL, DISCONNECT POWER SUPPLY	1
13	8.749-000.0	FUEL LINE ASSEMBLY	1	44	—	LABEL, SERIAL PLATE	1
14	8.752-034.0	FLANGE, KNA BURNER, 1" TUBE	1	46	9.807-339.0	LABEL, WIRING DIAGRAM, BURNER 115V-115V	1
15	8.752-035.0	FLANGE, KNA BURNER, 3" TUBE	1	46	9.807-340.0	LABEL, WIRING DIAGRAM, BURNER 230V-230V	4
16	8.750-539.0	GASKET, FLANGE	1	46	9.807-341.0	LABEL, WIRING DIAGRAM, BURNER 230V-115V	1
18	8.750-526.0	GUN, ELECTRODE / NOZZLE, 3"	1	46	9.807-342.0	LABEL, WIRING DIAGRAM, BURNER 115V-24V	1
19	8.750-525.0	GUN, ELECTRODE / NOZZLE, 1"	1	46	9.807-343.0	LABEL, WIRING DIAGRAM, BURNER 230V-24V	1
20	Varies	NOZZLE, FUEL	1	46	9.807-344.0	LABEL, WIRING DIAGRAM, BURNER 12VDC	1
21	8.750-778.0	ELECTRODE, IGNITION, AC	1	48	9.801-274.0	LABEL, BURNER LIGHTS	1
21	8.751-342.0	ELECTRODE, IGNITION, DC	1	49	8.919-105.0	PLATE, TERMINAL BLOCK NUMBERS	1
22	8.750-779.0	CONE, AIR F4	1	50	8.716-451.0	TERMINAL, JUMPER SPADE	1
22	8.750-782.0	CONE, AIR F6	1	51	9.802-510.0	CABLE, TIE, 4" BLACK	2
22	8.750-780.0	CONE, AIR F12	1	52	9.807-348.0	LABEL, CLEAR MYLAR	1
22	8.750-781.0	CONE, AIR F22	1	53	9.807-345.0	LABEL, IGNITER 120V	1
23	8.919-114.0	IGNITOR, BURNER 120V	1	53	9.807-346.0	LABEL, IGNITER 230V	1
23	8.919-115.0	IGNITOR, BURNER 230V	1	53	9.807-347.0	LABEL, IGNITOR 12VDC	1
23	8.919-116.0	IGNITOR, BURNER 12VDC	1	54	8.751-354.0	GASKET, BURNER TUBE	1

Replacement Parts KNA Burner "M/L"

For best performance specify genuine KNA replacement parts

Item #	Part #	Description	Qty
30	8.750-820.0	LIGHT, INDICATOR, GREEN 250V	1
31	8.750-784.0	SITE GLASS	1
32	8.750-785.0	RING, PUSH ON INTERNAL	1
33	8.733-001.0	SCREW, 8 x 1/4" HI LOW THREAD CUT	2
34	8.718-762.0	SCREW, 8-32 X 1/2", M PH RDH PL	4
35	9.802-745.0	Screw, 10/32 x 1/2 SHCS	1
36	8.718-810.0	SCREW, 10/32 X 1/2" WHIZ LOC FLANGE	9
37	8.750-770.0	SCREW, 10/32 x 5/8", WHIZ LOC FLANGE	3
38	8.750-816.0	SCREW, 10/32 X 1/4" GROUNDING	1
39	9.802-756.0	SCREW, 5/16" x 1", WHIZ LOC FLANGE	4
40	8.750-771.0	SCREW, 1/4-20 X 1/2", PHIL FHMS	4
41	9.802-750.0	SCREW, 8-32 X 1/2 M TPG PH PNH, BLACK	1
42	-	LABEL, BRAND NAME	1
43	9.801-268.0	LABEL, DISCONNECT POWER SUPPLY	1
44	-	LABEL, SERIAL PLATE	1
46	9.807-339.0	LABEL, WIRING DIAGRAM, BURNER 115V-115V	1
46	9.807-340.0	LABEL, WIRING DIAGRAM, BURNER 230V-230V	1
46	9.807-341.0	LABEL, WIRING DIAGRAM, BURNER 230V-115V	1
46	9.807-342.0	LABEL, WIRING DIAGRAM, BURNER 115V-24V	1
46	9.807-343.0	LABEL, WIRING DIAGRAM, BURNER 230V-24V	1
46	9.807-344.0	LABEL, WIRING DIAGRAM, BURNER 12VDC	1
46	9.807-551.0	LABEL, WIRING, BURNER 115V PRIMARY	1
46	9.807-552.0	LABEL, WIRING, BURNER 230V PRIMARY	1
48	9.801-273.0	LABEL, BURNER LIGHTS	1
49	8.919-105.0	PLATE, TERMINAL BLOCK NUMBERS	1
50	8.716-451.0	TERMINAL, JUMPER SPADE	1
51	9.802-510.0	CABLE, TIE, 4" BLACK	4
52	9.807-348.0	LABEL, CLEAR MYLAR, 1.125 x 4.50	1
53	9.807-345.0	LABEL, IGNITER 120V	1
53	9.807-346.0	LABEL, IGNITER 230V	1
53	9.807-347.0	LABEL, IGNITER 12VDC	1
54	8.751-354.0	GASKET, BURNER TUBE	1
55	8.753-100.0	PRIMARY CONTROL, HONEYWELL R7284U	1
56	8.753-101.0	CAD CELL FLAME DETECTOR, C554A	1
57	8.920-656.0	JUNCTION BOX, KNA BURNER ML	1
58	8.753-036.0	GASKET, IGNITER	1
59	8.921-214.0	BRACKET, FLAME SENSOR	1
60	9.802-640.0	COIL, OIL VALVE 120V, W/O CORDSET	1
60	9.802-641.0	COIL, OIL VALVE 230V W/O CORDSET	1
60	8.700-794.0	COIL, OIL VALVE 12/24V W/O CORDSET	1
61	9.804-072.0	CONDUIT, WIRE COVER	1

Item #	Part #	Description	Qty
1	8.752-865.0	BURNER HOUSING ASSEMBLY-M/L	1
3	8.700-758.0	FUEL PUMP, SUNTEC A2VA-3106 12-24V SOL	1
3	8.700-759.0	FUEL PUMP, SUNTEC A2VA-3106 120V SOL	1
3	8.700-760.0	FUEL PUMP, SUNTEC A2VA-3106 230V SOL	1
3	8.752-923.0	FUEL PUMP, SUNTEC A2YA-7916	1
4	8.752-924.0	SOLENOID VALVE, SUNTEC R642NL, 115V	1
4	8.752-925.0	SOLENOID VALVE, SUNTEC R753NL, 220V	1
4	8.753-030.0	SOLENOID VALVE, SUNTEC R261NL, 12/24V	1
6	8.752-919.0	AIR BAND ML	1
7	8.752-930.0	MOTOR, 1/4 HP 115V W/CAP NIDEC	1
7	8.752-931.0	MOTOR, 1/4 HP 230V W/CAP NIDEC	1
7	8.752-933.0	MOTOR, 1/5 HP 13.5VDC AMETEK N1CPM-156	1
7	8.752-932.0	MOTOR, 1/7 HP 115V EMERSON K41	1
7	8.753-574.0	MOTOR, 1/4 HP 115V US MOTOR	1
7	8.753-054.0	MOTOR, 1/7 HP 230V EMERSON K41	1
8	8.753-061.0	COUPLING, FLEX, 1/2" x 5/16" x 3-7/8" L	1
8	8.753-062.0	COUPLING, FLEX, 5/16" x 5/16" x 3-7/8" L	1
9	8.752-928.0	FAN, 6.25 x 3.50 x .50 BORE	1
9	8.752-929.0	FAN, 6.25 x 3.50 x .313 BORE	1
10	8.752-920.0	ELBOW, 37 DEG FLARE X 1/8" NPT 90 DEG	1
11	8.750-547.0	CONNECTOR, 37 DEG FLARE X 1/8" NPT, LONG	1
13	8.752-934.0	FUEL LINE ASSEMBLY, M	1
13	8.753-055.0	FUEL LINE ASSEMBLY, L	1
14	8.752-034.0	FLANGE 1" TUBE ASSY, BURNER	1
15	8.752-035.0	FLANGE 3" TUBE ASSY, BURNER	1
16	8.750-539.0	GASKET, FLANGE	1
18	8.750-526.0	GUN, ELECTRODE / NOZZLE, 3"	1
19	8.750-525.0	GUN, ELECTRODE / NOZZLE, 1"	1
20	Varies	FUEL NOZZLE	1
21	8.750-778.0	ELECTRODE, IGNITION AC	1
21	8.751-342.0	ELECTRODE, IGNITION DC	1
22	8.750-781.0	CONE, AIR F22	1
22	8.752-935.0	CONE, AIR F310	1
23	8.919-114.0	IGNITOR, BURNER 120V	1
23	8.919-115.0	IGNITOR, BURNER 230V	1
23	8.919-116.0	IGNITOR, BURNER 12VDC	1
24	8.706-745.0	PLUG, HOLE 0.812 PLASTIC	1
26	8.751-134.0	PLUG, 1/8" NPT X HEX SHOULDER	1
27	8.752-922.0	GASKET, JUNCTION BOX ML	1
28	8.920-654.0	COVER, JUNCTION BOX ML	1
29	8.750-116.0	BLOCK, TERMINAL, 5 POLE	1
30	8.750-818.0	LIGHT, INDICATOR, GREEN 28V	1
30	8.750-819.0	LIGHT, INDICATOR, GREEN 125V	1

Limited Warranty Information

The Karcher North America (KNA) corporation warrants to persons who purchase its "Products" from KNA for resale, or for incorporation in products for resale ("Customer") that its product is free from defects in material and workmanship for a period of 1 year from date of purchase. To qualify for warranty benefits, products must be installed by a qualified service technician in full compliance with all codes and authorities having jurisdiction and used within the tolerances of KNA defined product specifications.

NOTE: KNA Corporation is not responsible for any labor cost for removal and replacement of equipment.

LIMITATION OF LIABILITY

KNA'S liability for special, incidental, or consequential damages is expressly disclaimed. In no event shall KNA'S liability exceed the purchase price of the product in question. KNA makes every effort to ensure that all illustrations and specifications are correct, however, these do not imply a warranty that the product is merchantable or fit for a particular purpose, or that the product will actually conform to the illustrations and specifications. Our obligation under this warranty is expressly limited at our option to the replacement or repair at a service facility or factory designated by us, of such part or parts as inspection shall disclose to have been defective. **THE WARRANTY CONTAINED HEREIN IS IN LIEU OF ALL OTHER WARRANTIES, EXPRESS OR IMPLIED, INCLUDING ANY IMPLIED WARRANTY OF MERCHANTABILITY OR FITNESS FOR A PARTICULAR PURPOSE ARE EXPRESSLY LIMITED TO THE DURATION OF THIS WRITTEN WARRANTY.** KNA does not authorize any other party, including authorized KNA Dealers, to make any representation or promise on behalf of KNA, or to modify the terms, conditions, or limitations in any way. It is the buyer's responsibility to ensure that the installation and use of KNA products conforms to local codes. While KNA attempts to assure that its products meet national codes, it cannot be responsible for how the customer chooses to use or install the product. Some states do not allow limitations on how long an implied warranty lasts or the exclusion or limitation of incidental or consequential damages, so the above limitation or exclusion may not apply to you.



USA: 4275 NW Pacific Rim Blvd - Camas, WA 98607
Phone: 800-833-1600 FAX: 800-833-9200



USA: 4275 NW Pacific Rim Blvd - Camas, WA 98607

Phone: 800-833-1600 FAX: 800-833-9200

Printed in USA • Revised 3/14