

KÄRCHER

makes a difference

Spare Parts List

Chariot 2 iGloss 20

1.002-031.0	<i>CBPS20</i>
1.002-032.0	<i>CBPSC20</i>
1.002-033.0	<i>CBPL20</i>
1.002-034.0	<i>CBPLC20</i>
1.002-035.0	<i>CBAL20</i>
1.002-036.0	<i>CBALC20</i>

From Serial Number (Ref No. 1*)
* See Serial Number page
or call manufacturer.

Table of contents

CHARIOT iGLOSS 20", SB, PASS, SHLF CHRGR (ALL MODELS)	2
40 BODY BRACE	3
50 BODY LOWER	5
60 BODY LOWER MOUNTING	7
70 BUMPER	9
80 BURNISHING DECK	11
90 BURNISHING DECK MOUNTING	13
110 BURNISHING DECK - PAD DRIVER	15
120 CONSOLE - BAG ENCLOSURE	17
130 CONSOLE - HINGE	19
140 CONTROL PANEL 1	21
150 CONTROL PANEL 2	23
160 CHARGER - OPTIONAL	25
170 DECALS	27
180 SLEW/STEERING-FROM SERIAL NUMBER (3*)	29
190 DRIVE-CHAIN PRIOR TO SERIAL NUMBER (3*)	31
200 DRIVE LOWER - FROM SERIAL NUMBER (3*)	33
1 Traction motor C2 (8.641-117.0)	36
210 DRIVE-LOWER PRIOR TO SERIAL NUMBER (3*)	38
5 Wheel drive motor (8.636-401.0)	41
220 FRAME & REAR WHEELS	43
230 DRIVE MOUNTING - FROM SERIAL NUMBER (3*)	45
240 DRIVE MOUNTING - PRIOR TO SN (3*)	47
250 PEDAL PLATFORM	49
260 PEDAL PLATFORM MOUNTING	51
270 STEERING	53
280 VACUUM - OPTIONAL	55
290 WIRING - BATTERY	56
9020 Chariot iGloss 20 Serial Numbers	58



CHARIOT iGLOSS 20", SB, PASS, SHLF CHRGR (ALL MODELS)

POS	Description	Quantity	Unit
40	BODY BRACE	1	PC
50	BODY LOWER	1	PC
60	BODY LOWER MOUNTING	1	PC
70	BUMPER	1	PC
80	BURNISHING DECK	1	PC
90	BURNISHING DECK MOUNTING	1	PC
100	BURNISHING DECK LIFT	1	PC
110	BURNISHING DECK - PAD DRIVER	1	PC
120	CONSOLE - BAG ENCLOSURE	1	PC
130	CONSOLE - HINGE	1	PC
140	CONTROL PANEL 1	1	PC
150	CONTROL PANEL 2	1	PC
160	CHARGER - OPTIONAL	1	PC
170	DECALS	1	PC
180	SLEW/STEERING-FROM SERIAL NUMBER (3*)	1	PC
190	DRIVE-CHAIN PRIOR TO SERIAL NUMBER (3*)	1	PC
200	DRIVE LOWER - FROM SERIAL NUMBER (3*)	1	PC
210	DRIVE-LOWER PRIOR TO SERIAL NUMBER (3*)	1	PC
220	FRAME & REAR WHEELS	1	PC
230	DRIVE MOUNTING - FROM SERIAL NUMBER (3*)	1	PC
240	DRIVE MOUNTING - PRIOR TO SN (3*)	1	PC
250	PEDAL PLATFORM	1	PC
260	PEDAL PLATFORM MOUNTING	1	PC
270	STEERING	1	PC
280	VACUUM - OPTIONAL	1	PC
290	WIRING - BATTERY	1	PC
9020	Chariot iGloss 20 Serial Numbers	1	PC

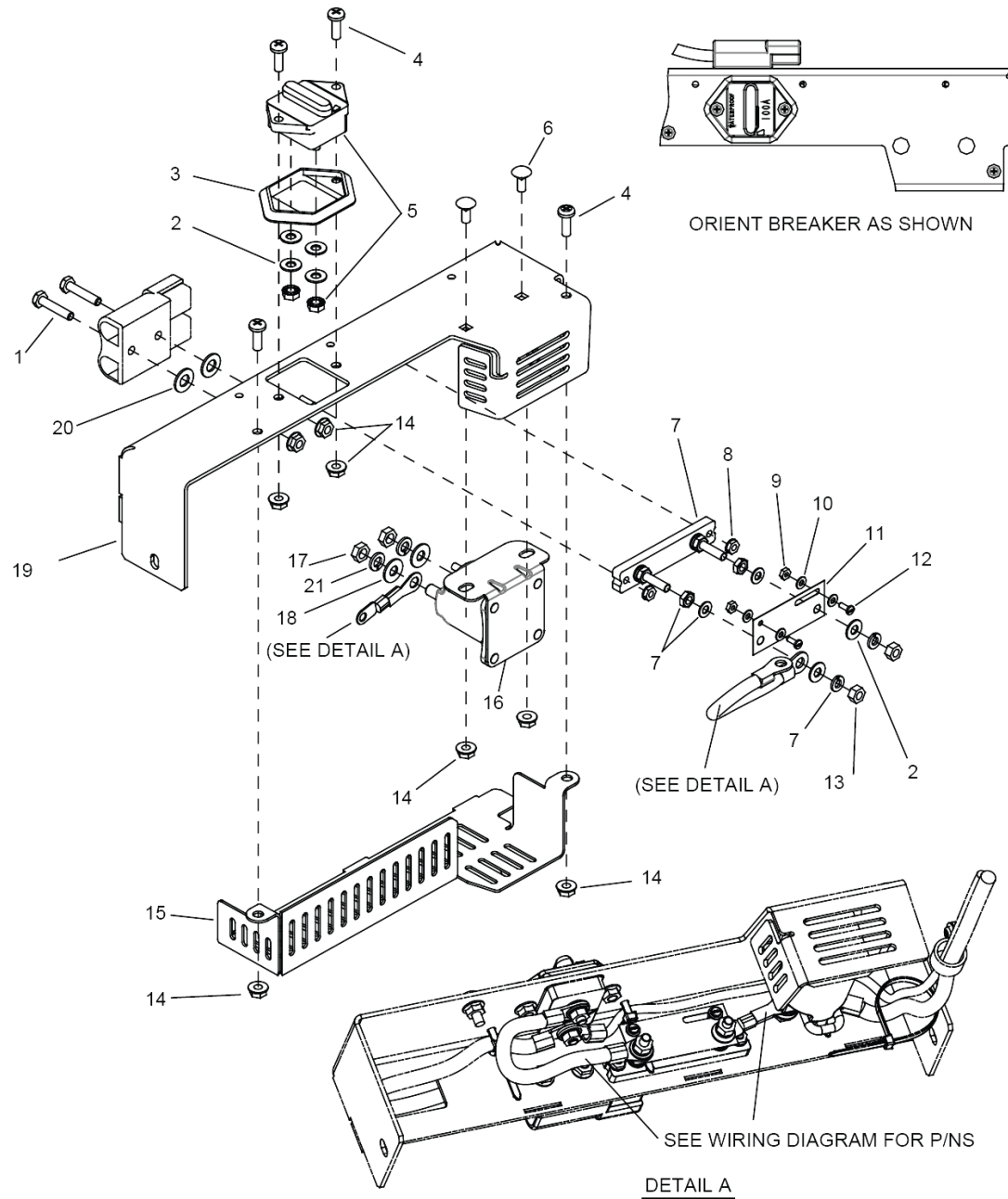

40 BODY BRACE

POS	Article no.	Description	Quantity	Unit
1	8.627-382.0	SCREW, 1/4-20 X 1.25 HHMS SS	2	PC
2	8.601-063.0	WASHER, 1/4 SS	6	PC
3	8.634-002.0	COVER, PANEL MNT BREAKER	1	PC
4	8.627-512.0	SCREW, 1/4-20 X .75 PHPNHMS STL ZNPLT	4	PC
5	8.634-003.0	BREAKER, 100A CIRCUIT	1	PC
6	8.627-750.0	SCREW, 1/4-20 X .625 CARR SS	2	PC
7	8.622-977.0	BLOCK, SHUNT MOUNT	1	PC
8	8.600-570.0	NUT, 10-32 HEXSTRW LK STL ZNPLT	2	PC
9	8.627-179.0	NUT, 6-32 HEX BRS	2	PC
10	8.627-960.0	WASHER, 6 FLT BRS	4	PC
11	8.625-360.0	SHUNT, 50MV 70AMP	1	PC
12	8.627-625.0	SCREW, 6-32 X .375 SLTDPNHMS BRS	2	PC
13	8.627-077.0	Nut	2	PC
14	8.627-137.0	NUT, 1/4-20 SERFLG STL ZNPLT	8	PC
15	8.635-327.0	BRACKET, CONTACTOR COVER	1	PC
16	8.637-145.0	RELAY 36VDC 100A HD	1	PC
17	8.627-112.0	NUT, 5/16-18 HEX BRS	2	PC
18	8.601-067.0	WASHER, 5/16 FLT SS	2	PC
19	8.635-326.0	BRACKET, SOL TANK BRACE	1	PC
20	8.601-068.0	WASHER, 3/8 NYL	2	PC
21	8.627-913.0	Washer 5/16 SPLIT LOCK PLTD	2	PC

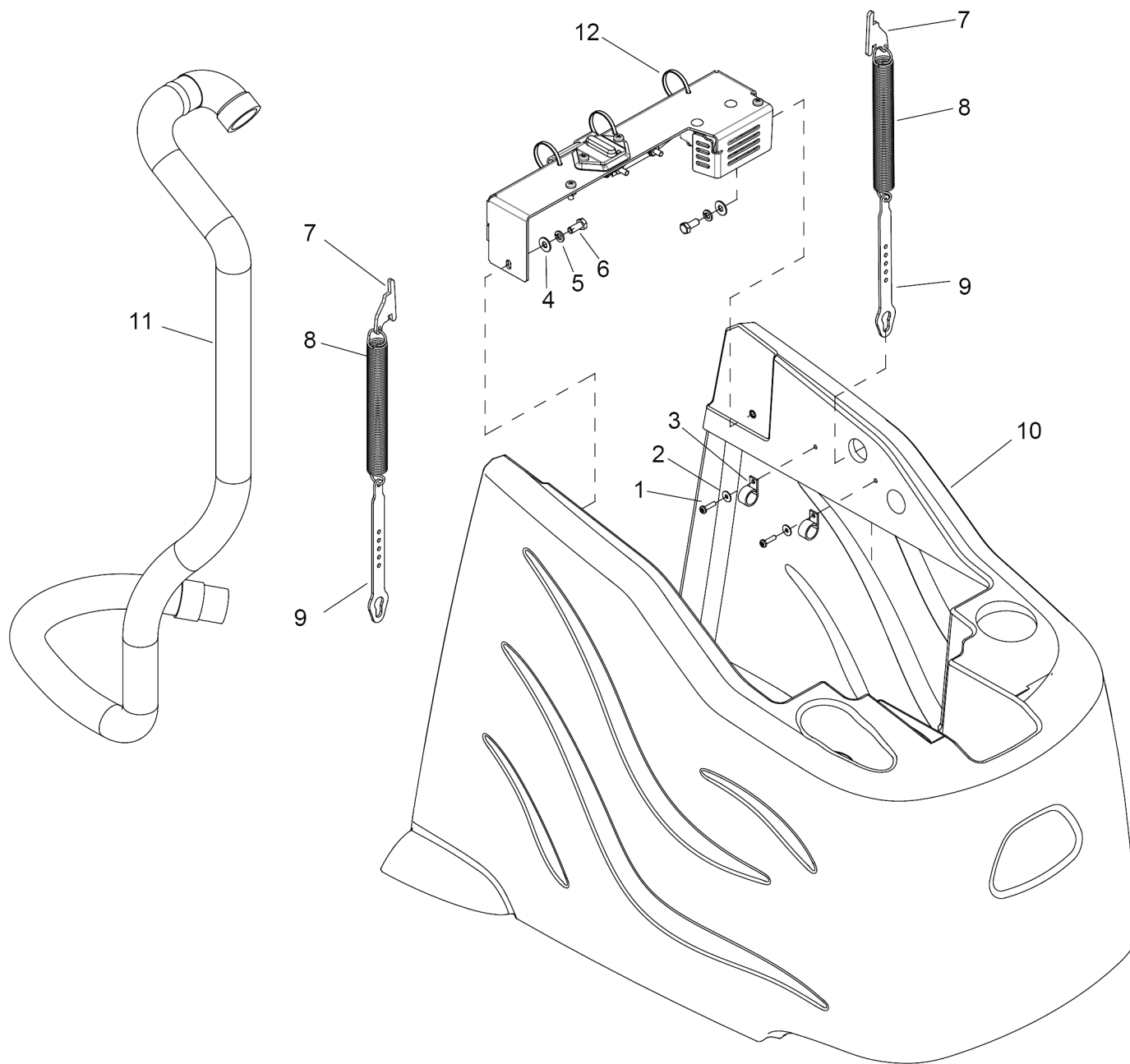

50 BODY LOWER

POS	Article no.	Description	Quantity	Unit	Remark
1	8.627-398.0	SCREW, 10-32 X .75 PHPNHMS SS	2	PC	
2	8.601-065.0	WASHER, .203 X .562 X .040 FLT	2	PC	
3	8.635-499.0	CLAMP, .75 DIA, FLEX LOOP, NYLON	2	PC	
4	8.601-067.0	WASHER, 5/16 FLT SS	2	PC	
5	8.627-913.0	Washer 5/16 SPLIT LOCK PLTD	4	PC	
6	8.627-678.0	SCREW, 5/16-18 X .75 HHCS SS	2	PC	
7	8.635-457.0	BRACKET, SPRING, UPPER	2	PC	
8	8.635-322.0	SPRING, EXTENSION	2	PC	
9	8.635-372.0	BRACKET, SPRING, LOWER	2	PC	
9	8.638-495.0	Bracket spring lower	2	PC	Required for 86384690
10	8.636-841.0	Main body	1	PC	
10	8.637-770.0	MAIN BODY, NO OBC, GRAY, TRIM	1	PC	
	Item text1: SHELF CHARGER MODELS ONLY,				
	Item text2: 1.002-033.0 AND 1.002-035.0				
11	8.635-328.0	Hose	1	PC	
12	8.626-494.0	Cable tie 11.38" UL/CSA	3	PC	

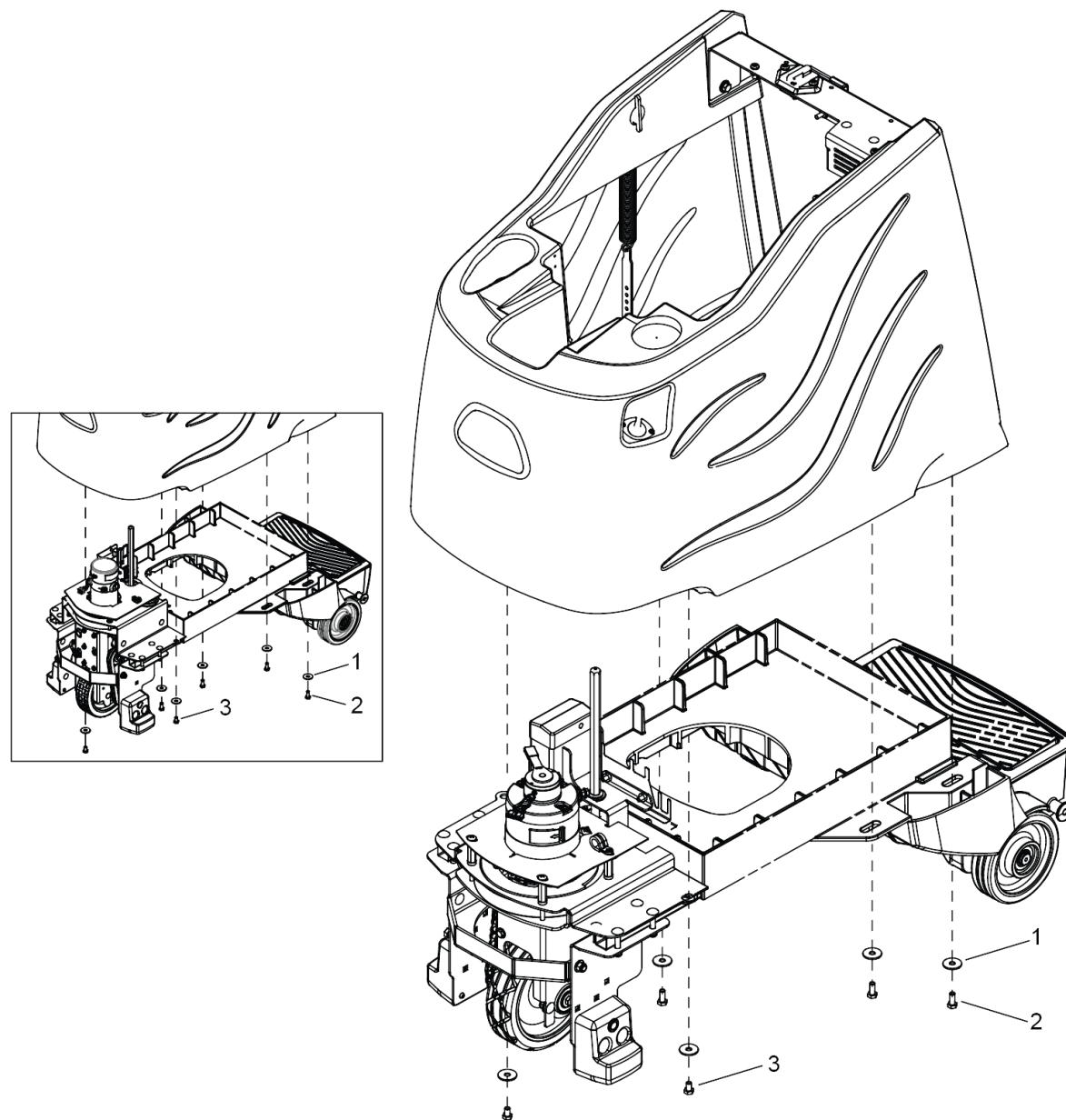

SEE SERIAL NUMBER PAGE FOR REFERENCE

60 BODY LOWER MOUNTING

POS	Article no.	Description	Quantity	Unit	valid from
1	8.627-963.0	WASHER, 5/16 X 1.13 X .09 FLT	5	PC	*(3)
	Item text1: QTY WAS 6				
2	8.600-676.0	SCREW, 5/16-18 X .75 HHCS	3	PC	*(3)
	Item text1: QTY WAS 4				
3	8.627-518.0	SCREW, 5/16-18 X .5 STL GR5 ZNPLT	2	PC	

70 BUMPER

POS	Article no.	Description	Quantity	Unit
1	8.636-682.0	BUMPER, TRIM, BLACK	1	PC
2	8.627-698.0	SCREW, 5/16-18 X 2 HHCS SS	2	PC
3	8.601-067.0	WASHER, 5/16 FLT SS	7	PC
4	8.627-607.0	SCREW, 5/16-18 X .75 CARR SS	4	PC
5	8.627-083.0	NUT, 5/16-18 HEX NYLOCK SS	4	PC
6	8.632-395.0	PAD TIP	2	PC
7	7.303-104.0	Screw 5x16 -A2-70 (IN6RD)	2	PC
8	8.627-184.0	NUT, 5/16-18 HEXTHIN NYLOCK SS	1	PC
9	8.632-791.0	SCREW, KA50 X 25 PTOVHS STL WN1412 ZNPLT	2	PC
10	8.625-613.0	STRAP, STATIC, .2T X 1W X 3L	1	PC
11	8.627-963.0	WASHER, 5/16 X 1.13 X .09 FLT	1	PC
12	8.600-676.0	SCREW, 5/16-18 X .75 HHCS	1	PC
13	8.635-951.0	BRKT, STATIC STRAP	1	PC

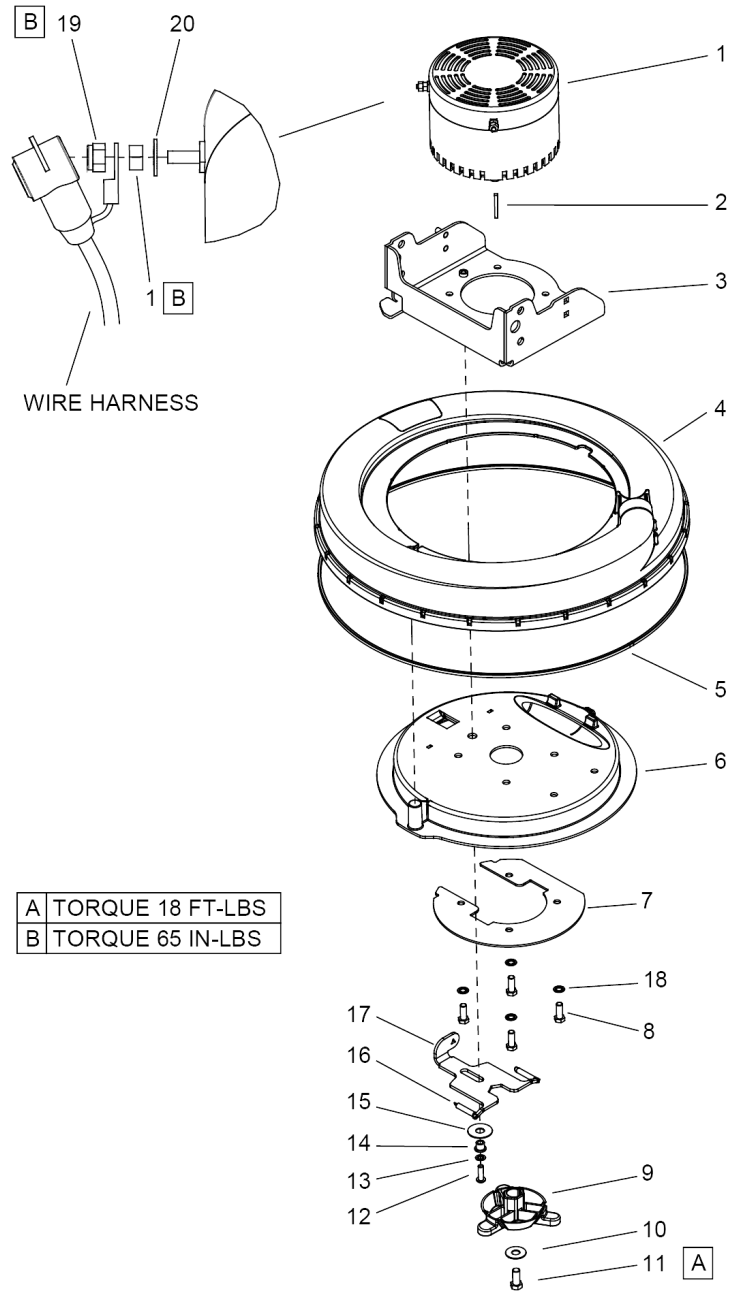

80 BURNISHING DECK

POS	Article no.	Description	Quantity	Unit	Remark
-	8.634-801.0	Brush set	1	PC	
1	8.638-469.0	Brush motor 2.2 kW	1	PC	Requires 86384950
2	8.628-685.0	KEY, 3/16 X 3/16 X 1.5 LCST GR1018	1	PC	
3	8.635-347.0	BRACKET, MOTOR LIFT	1	PC	
4	8.635-291.0	SHROUD, OUTER	1	PC	
5	8.635-378.0	Brush	1	PC	
6	8.635-290.0	SHROUD, INNER	1	PC	
7	8.635-375.0	PLATE, SUPPORT, INNER SHROUD	1	PC	
8	8.627-692.0	SCREW, 3/8-16 X 1 HHCS SS NP	4	PC	
9	8.637-214.0	HUB, PAD DRIVER	1	PC	
10	8.601-071.0	WASHER, 7/16 FLT STL YW ZNPLT	1	PC	
11	8.627-754.0	SCREW, 7/16-20 X 1 HHCS STL GR5 ZNPLT	1	PC	
12	8.600-693.0	SCREW, 5/16-18 X 1 SCHBTNHCS SS	1	PC	
13	8.633-099.0	WASHER, 5/16 INTLK SS	1	PC	
14	8.622-884.0	BUSHING, .314 X .502 X .5 FLG	1	PC	
15	8.627-903.0	WASHER, .515 X 1.47 X .05 FLT NYL	1	PC	
16	8.600-791.0	Spring EXT .31D X 2.0L X .03W	2	PC	
17	8.635-376.0	BRACKET, MOTOR LOCK	1	PC	
18	8.627-911.0	WASHER, 3/8 INTLK	4	PC	
19	8.643-726.0	Nut 5/16-18 HEX LK BRS	2	PC	
20	8.601-067.0	WASHER, 5/16 FLT SS	2	PC	

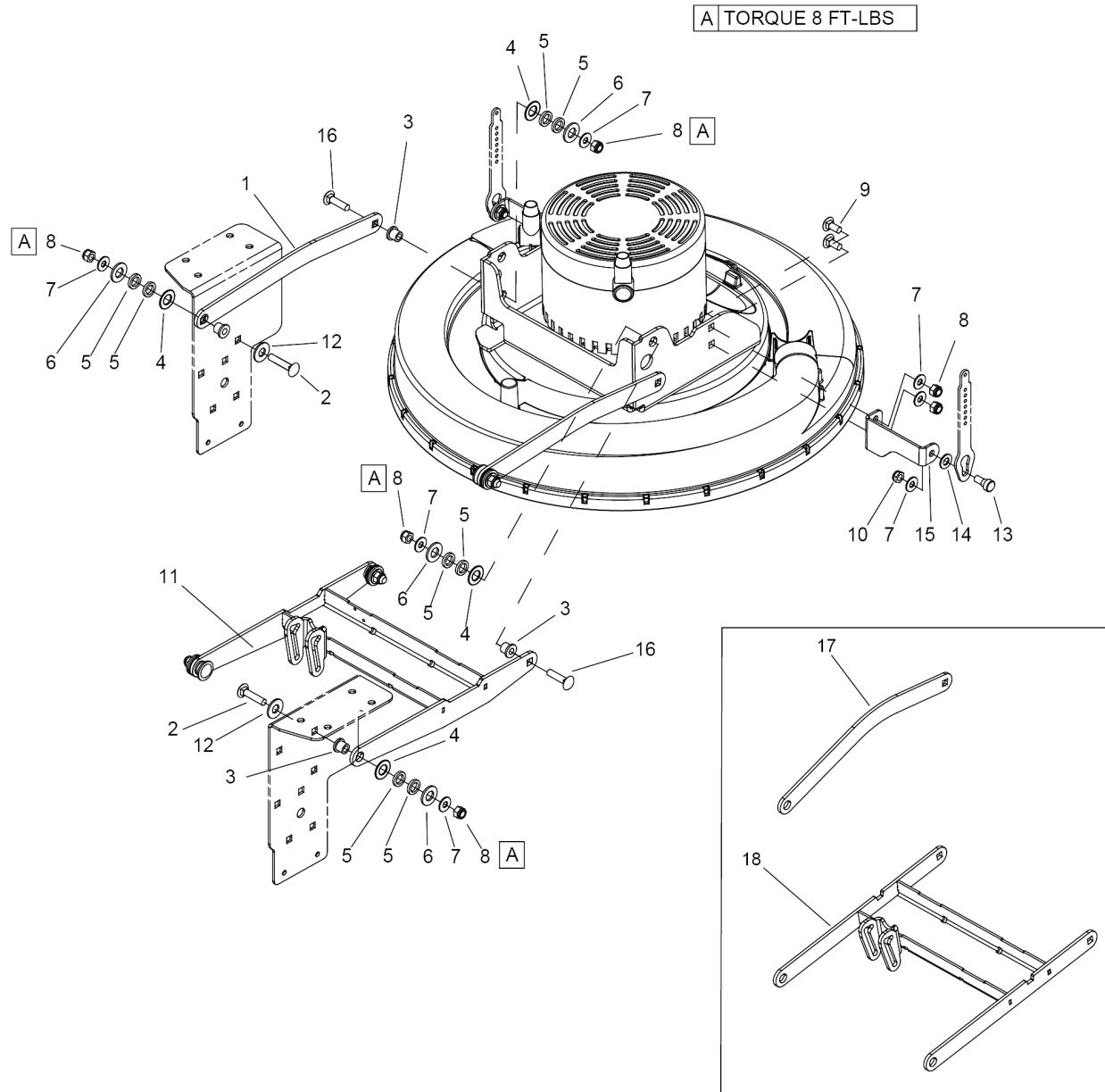

SEE SERIAL NUMBER PAGE FOR REFERENCE

90 BURNISHING DECK MOUNTING

POS	Article no.	Description	Quantity	Unit	valid from
1	8.638-852.0	DECK LINKAGE ARM	2	PC	(5*)
2	8.627-747.0	SCREW, 5/16-18 X 1.5 CARR SS	4	PC	
3	8.622-884.0	BUSHING, .314 X .502 X .5 FLG	8	PC	
4	8.625-941.0	WASHER, .51 X 10 X .063 THR	8	PC	
5	8.627-935.0	WASHER, 1/2 X .771 X .013 WV	16	PC	
6	8.625-942.0	WASHER, .510 X 1 THR	8	PC	
7	8.601-067.0	WASHER, 5/16 FLT SS	14	PC	
8	8.627-083.0	NUT, 5/16-18 HEX NYLOCK SS	12	PC	
9	8.627-607.0	SCREW, 5/16-18 X .75 CARR SS	2	PC	
10	8.627-184.0	NUT, 5/16-18 HEXTHIN NYLOCK SS	2	PC	
11	8.638-850.0	TOP LINK ASSY	1	PC	(5*)
12	8.601-077.0	WASHER, 7/16 X1 X .08 FLT SS	4	PC	
13	8.635-381.0	SHOULDER BOLT, 3/8 X .25L SS	2	PC	
14	8.601-068.0	WASHER, 3/8 NYL	2	PC	
15	8.635-380.0	Holder	2	PC	
16	8.627-703.0	SCREW, 5/16-18 X 1.25 CARR SS	4	PC	
17	8.635-379.0	BRACKET, LINKAGE ARM	2	PC	
18	8.635-374.0	BRACKET, LIFT ASSY, TOP	1	PC	

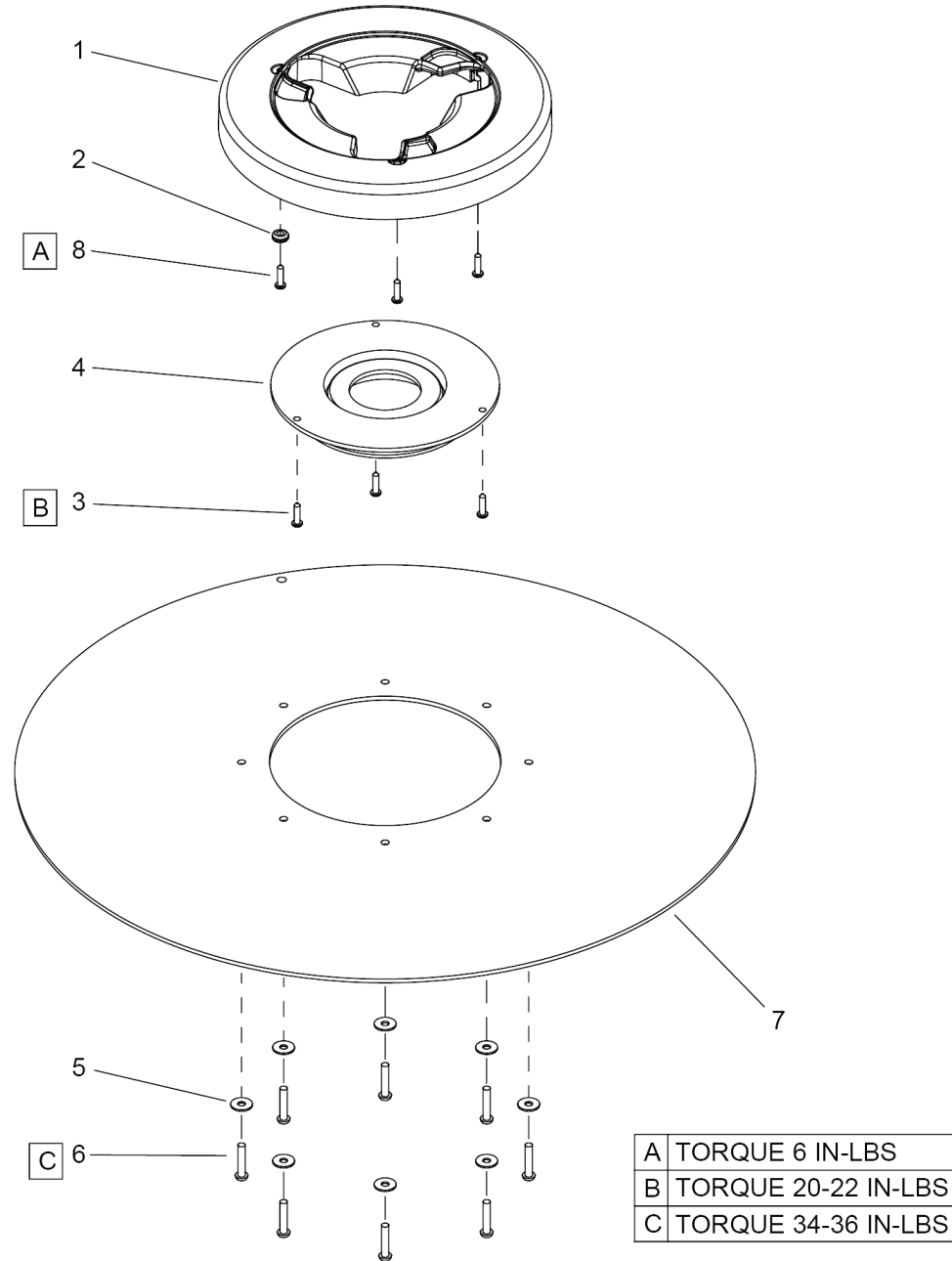

110 BURNISHING DECK - PAD DRIVER

POS	Article no.	Description	Quantity	Unit
1	8.635-246.0	HUB, PAD DRIVER	1	PC
2	8.635-565.0	GROMMET, .155ID X .438OD X .188T	1	PC
3	8.617-314.0	SCREW, KA40 X 10 OVHCS STL WIN1412 ZNPLT	3	PC
4	8.635-562.0	RETAINER, PAD CENTER LOCK	1	PC
5	8.617-333.0	WASHER, M5 SS ISO7093	8	PC
6	8.632-791.0	SCREW, KA50 X 25 PTOVHS STL WN1412 ZNPLT	8	PC
7	8.635-561.0	Pad drive	1	PC
8	8.635-166.0	SCREW, 6-19 X .5 PHPNH SMS HL STL ZNPLT	3	PC
8	8.635-845.0	ASM, PAD DRIVER iGLOSS 20	1	PC
Item text1: NOT SHOWN				

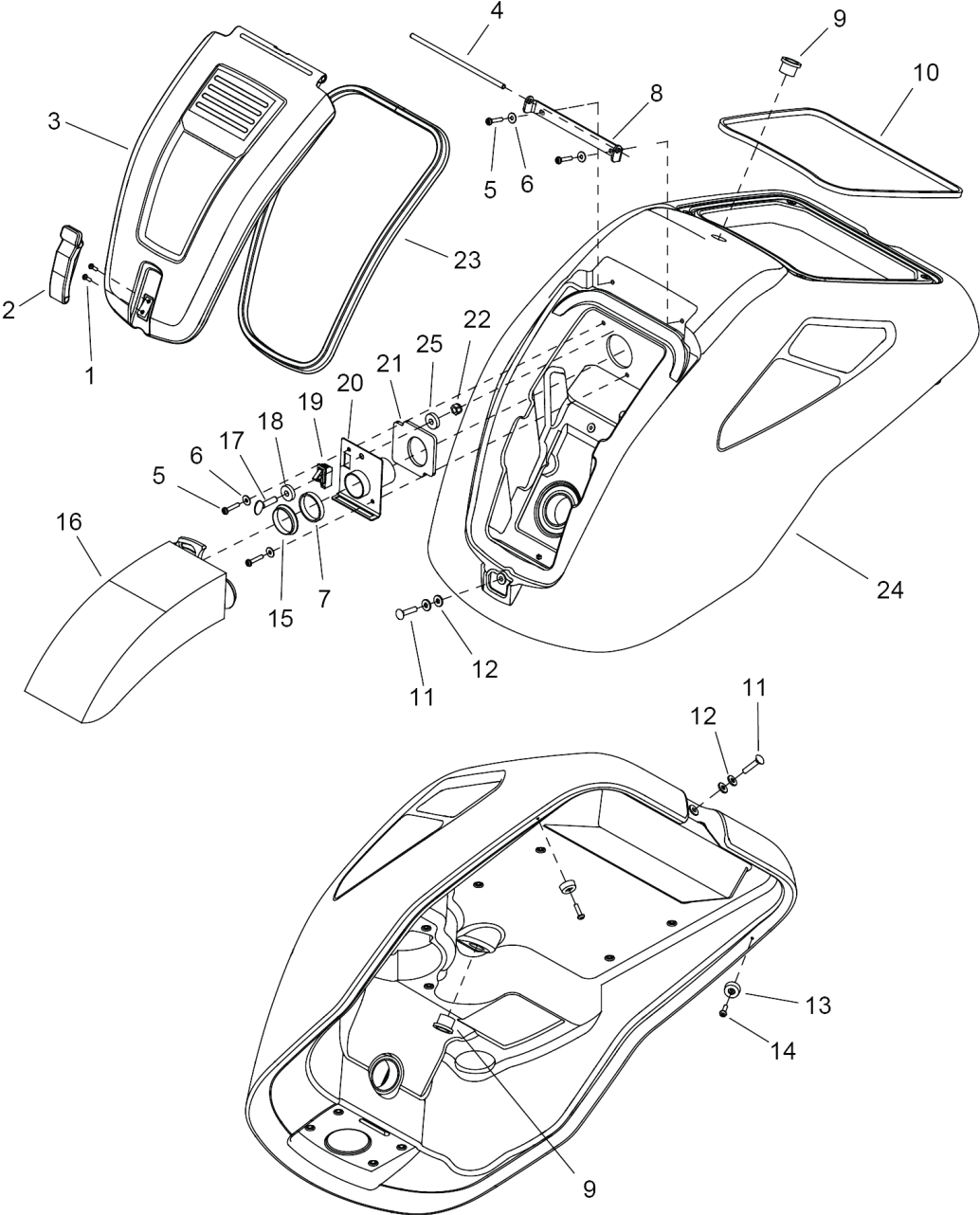

120 CONSOLE - BAG ENCLOSURE

POS	Article no.	Description	Quantity	Unit
1	8.617-314.0	SCREW, KA40 X 10 OVHCS STL WIN1412 ZNPLT	2	PC
2	8.616-180.0	Snap fastener	1	PC
3	8.636-843.0	COVER, BAG ENCL, BLK	1	PC
4	8.635-365.0	SHAFT, .25 X 7.3, SS	1	PC
5	8.627-581.0	SCREW, 10-32 X 1 PHPNHMS STL BLKOX	4	PC
6	8.601-065.0	WASHER, .203 X .562 X .040 FLT	4	PC
7	8.635-926.0	WASHER, 1.5 X 1.7 X .19 NPRN	1	PC
8	8.635-317.0	BRKT, HINGE	1	PC
9	8.622-879.0	BUSHING, .753 X .875 X .75 FLG	2	PC
10	8.632-783.0	GASKET,.188X.31X41.0	1	PC
11	8.627-633.0	SCREW, 1/4-20 X 1.25 CARR	2	PC
12	8.627-952.0	WASHER, 1/4 FLT STL BLK ZNPLT	4	PC
13	8.635-613.0	BUMPER, 7/8OD X 13/32H, RUBBER	2	PC
14	8.600-660.0	SCREW, 10-16 X .75 PHPNH HL SS	2	PC
15	8.635-464.0	WASHER, 1.5ID SINK, RUBBER	1	PC
16	8.633-398.0	FILTER BAGS (PACK OF10)	1	ZST
17	8.600-704.0	SCREW, 5/16-18 X 1 THUMB SS	1	PC
18	8.635-682.0	WASHER, .315 X .89 X .215 NYL	1	PC
19	8.632-768.0	SWITCH, INTERLOCK	1	PC
20	8.635-459.0	BRACKET, BAG MOUNT	1	PC
21	8.635-463.0	GASKET, BAG MOUNT	1	PC
22	8.627-184.0	NUT, 5/16-18 HEXTHIN NYLOCK SS	1	PC
23	8.644-817.0	BAG COVER GASKET 43.6	1	PC
24	8.636-680.0	CONSOLE, IGLOSS 20 TRIMMED GRAY	1	PC
		Item text1: ACTIVE DUST CONTROL		
24	8.639-950.0	CONSOLE, PASSIVE, TRIMMED	1	PC
		Item text1: PASSIVE DUST CONTROL		
25	8.600-832.0	Spacer washer	1	PC

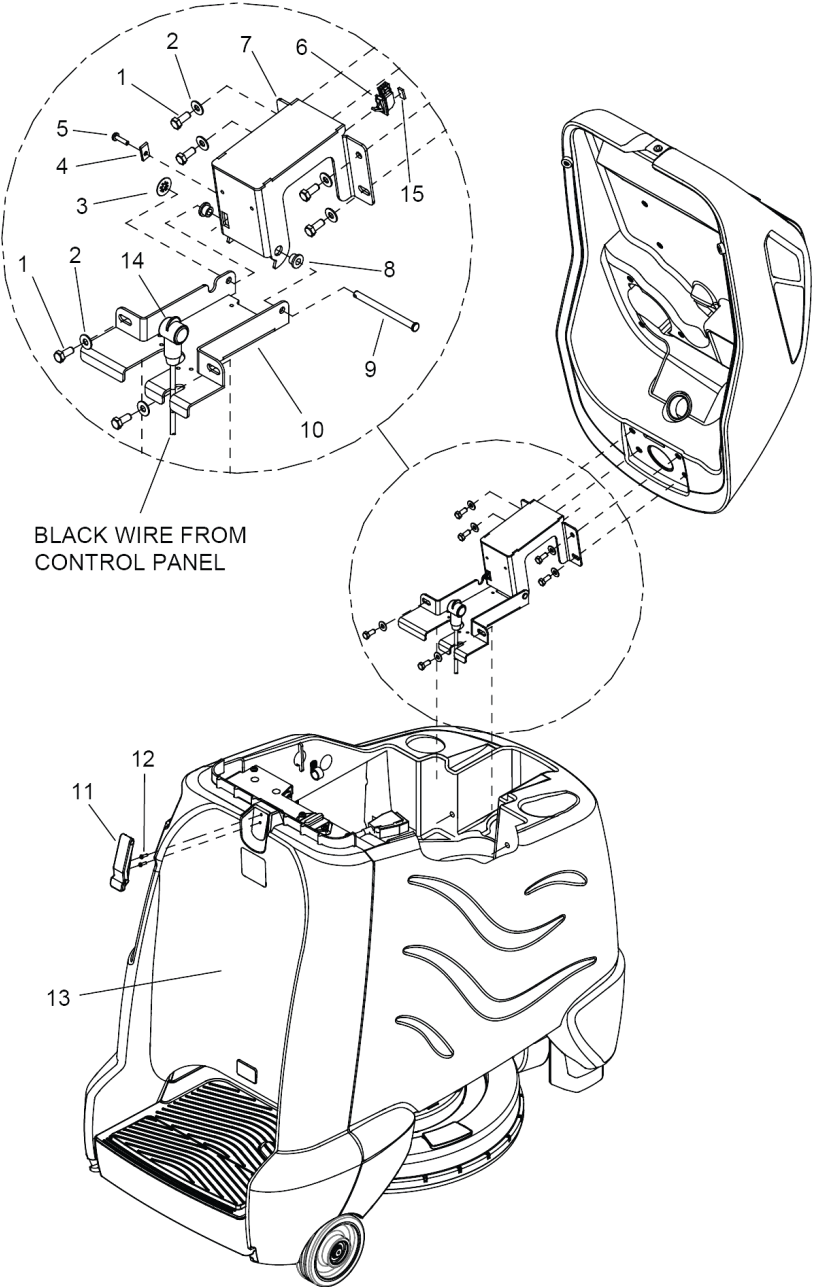

130 CONSOLE - HINGE

POS	Article no.	Description	Quantity	Unit
1	8.627-678.0	SCREW, 5/16-18 X .75 HHCS SS	6	PC
2	8.601-067.0	WASHER, 5/16 FLT SS	6	PC
3	8.632-886.0	NUT, 5/16 PUSH LK STL ZNPLT	1	PC
4	8.627-086.0	NUT, 10-24 TYPEU BLK	1	PC
5	8.627-711.0	SCREW, 10-24 X .75 PHPNHMS SS	1	PC
6	8.632-768.0	SWITCH, INTERLOCK	1	PC
7	8.632-632.0	Holder hinge above	1	PC
8	8.622-899.0	BUSHING, .314 X .502 X .375 FLG BRZ	2	PC
9	8.632-634.0	PIN, CLEVIS 5/16 X 4 STL ZNPLT	1	PC
10	8.635-501.0	BRKT, HINGE LOWER	1	PC
11	8.616-180.0	Snap fastener	1	PC
12	8.617-314.0	SCREW, KA40 X 10 OVHCS STL WIN1412 ZNPLT	2	PC
13	8.636-836.0	PANEL, BACK TRIMMED, BLK	1	PC
14	8.600-892.0	BOOT, RUBBER TERM. ISOLATOR	1	PC

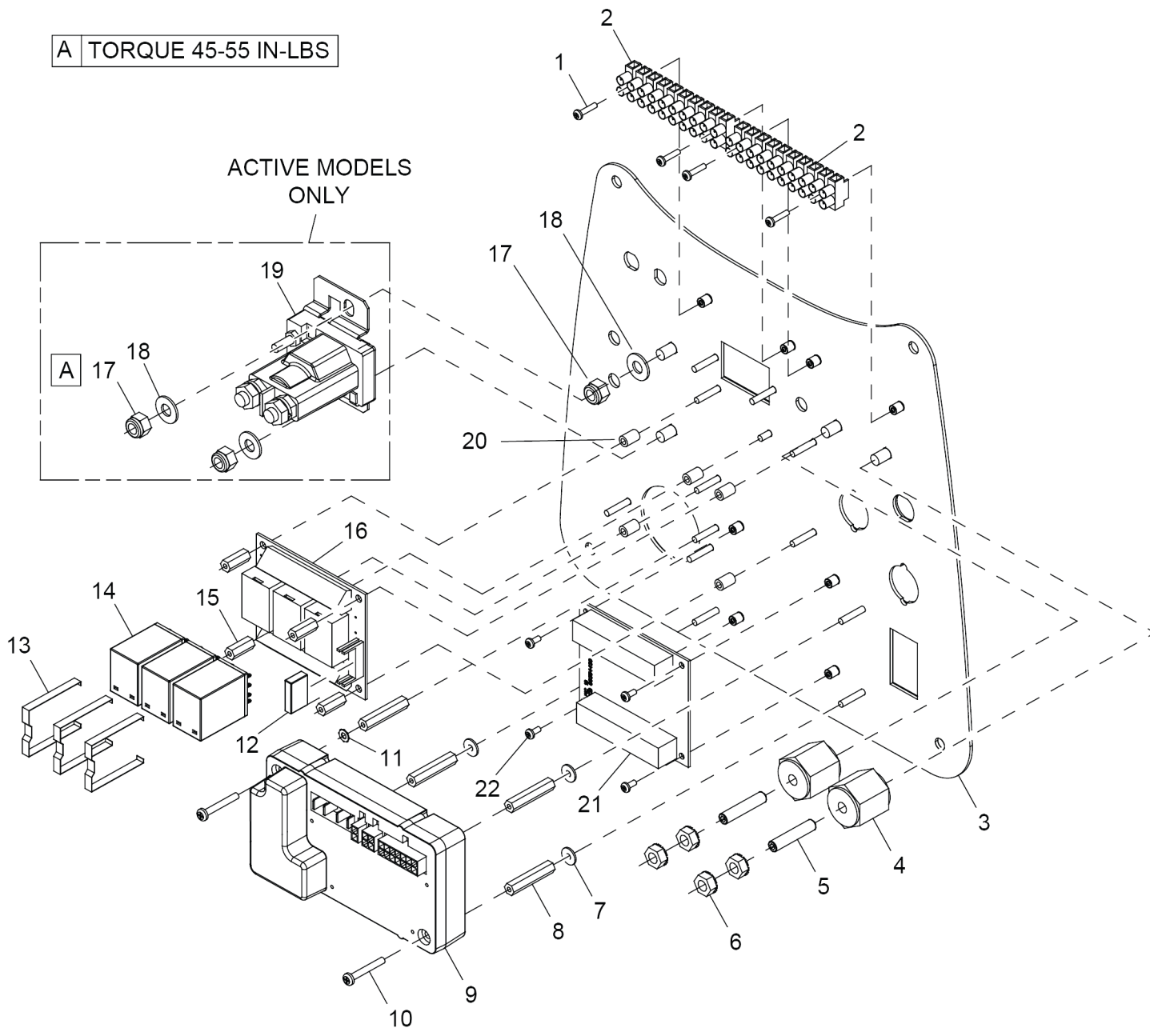

140 CONTROL PANEL 1

POS	Article no.	Description	Quantity	Unit	valid from	valid until
1	8.627-526.0	SCREW, 4-40 X .5 PHPNHMS STL ZNPLT	4	PC		
2	8.632-639.0	CONN, 8MM PITCH, 10 POS	2	PC		
3	8.635-249.0	PANEL, CONTROL iGLOSS 20	1	PC		
4	8.625-591.0	STANDOFF, 1/4-20 X 1.0 HEX INS	2	PC		
5	8.600-685.0	SCREW, 1/4-20 X 1.25 SCHSET CP SS	1	PC		
6	8.600-571.0	NUT, 1/4-20 HEXSTRW LK STL ZNPLT	4	PC		
7	8.627-945.0	WASHER, 6 FLT STL ZNPLT	3	PC		
8	8.635-486.0	Standoff	4	PC		
9	8.635-632.0	CONTROLLER, iGLOSS 20	1	PC		(3*)
9	8.638-597.0	Controller C2B	1	PC	(*3)	
10	8.627-555.0	SCREW, 6-32 X 1.25 PHPNHMS STL ZNPLT	2	PC		
11	8.627-902.0	WASHER, 6 EXTLK SS	1	PC		
12	8.633-611.0	Relay two-pole	1	PC		
13	8.633-610.0	Clip relay	3	PC		
14	8.631-390.0	RELAY, 5A, 24V, 4PDT	3	PC		
15	8.625-590.0	Distance pin	4	PC		
16	8.633-609.0	CIRCUIT BOARD, 4 RELAY	1	PC		
17	8.627-187.0	NUT, 1/4-20 HEXTHIN NYLOCK SS	1	PC		
		Item text1: ACTIVE MODEL - QTY 2				
		Item text2: PASSIVE MODEL - QTY 1				
18	8.601-063.0	WASHER, 1/4 SS	1	PC		
		Item text1: ACTIVE MODEL - QTY 2				
		Item text2: PASSIVE MODEL - QTY 1				
19	8.625-136.0	Relay 36VDC 100A	1	PC		
		Item text1: ACTIVE MODEL ONLY				
20	8.633-721.0	SPACER, .14ID X .28OD X .38, NYL	5	PC		
21	8.635-443.0	Electronics printed circuit board	1	PC		
22	8.627-457.0	SCREW, 4-40 X .25 PHPNHMS STL ZNPLT	4	PC		

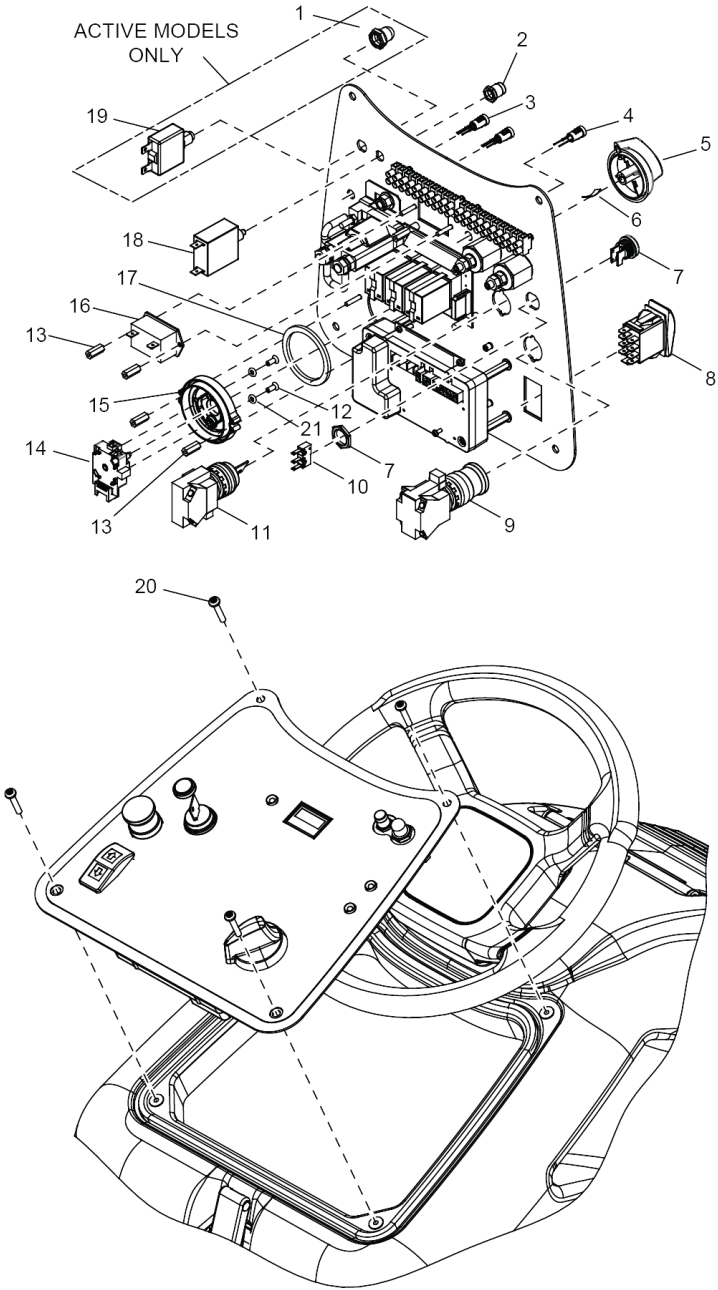

150 CONTROL PANEL 2

POS	Article no.	Description	Quantity	Unit
1	8.633-251.0	BOOT, SEAL PUSH BUTTON 11MM	1	PC
	Item text1: ACTIVE MODEL ONLY			
2	8.600-126.0	BOOT, CB 3/8-32 UNS	1	PC
3	8.634-864.0	Pilot lamp LED filter	2	PC
4	8.634-896.0	Pilot lamp LED battery	1	PC
5	5.321-738.0	Handhold operational concept	1	PC
6	6.313-014.0	Spring element	1	PC
7	8.629-520.0	ASM, BUTTON, BLACK, W/BEZEL	1	PC
8	8.631-395.0	SWITCH, SPDT 3 POSN MOM, ARROW	1	PC
9	8.629-259.0	SWITCH, E-STOP AKW CHARIOT	1	PC
10	8.629-278.0	SWITCH, MICRO	1	PC
11	8.600-717.0	Switch KEY TWO POSITION	1	PC
12	8.635-843.0	SCREW, M4 X 12 FLHMS SS ISO7046 NP	2	PC
13	8.625-590.0	Distance pin	4	PC
14	8.635-487.0	SWITCH, ROTARY	1	PC
15	8.635-456.0	BEZEL, ROTARY SWITCH	1	PC
16	8.631-547.0	METER, HOUR ICD	1	PC
17	8.635-481.0	GASKET, ROTARY SWITCH	1	PC
18	8.635-368.0	BREAKER, 1.5A CARLING MAGNETIC	1	PC
19	8.631-616.0	BREAKER, 18A, 250VAC, 32VDC	1	PC
	Item text1: ACTIVE MODEL ONLY			
20	8.637-141.0	SCREW, 10-32 X .75 TMS SS BLK	4	PC
21	8.635-844.0	O-RING, 4MM ID, 1.5MM THK, BUNA-N	2	PC

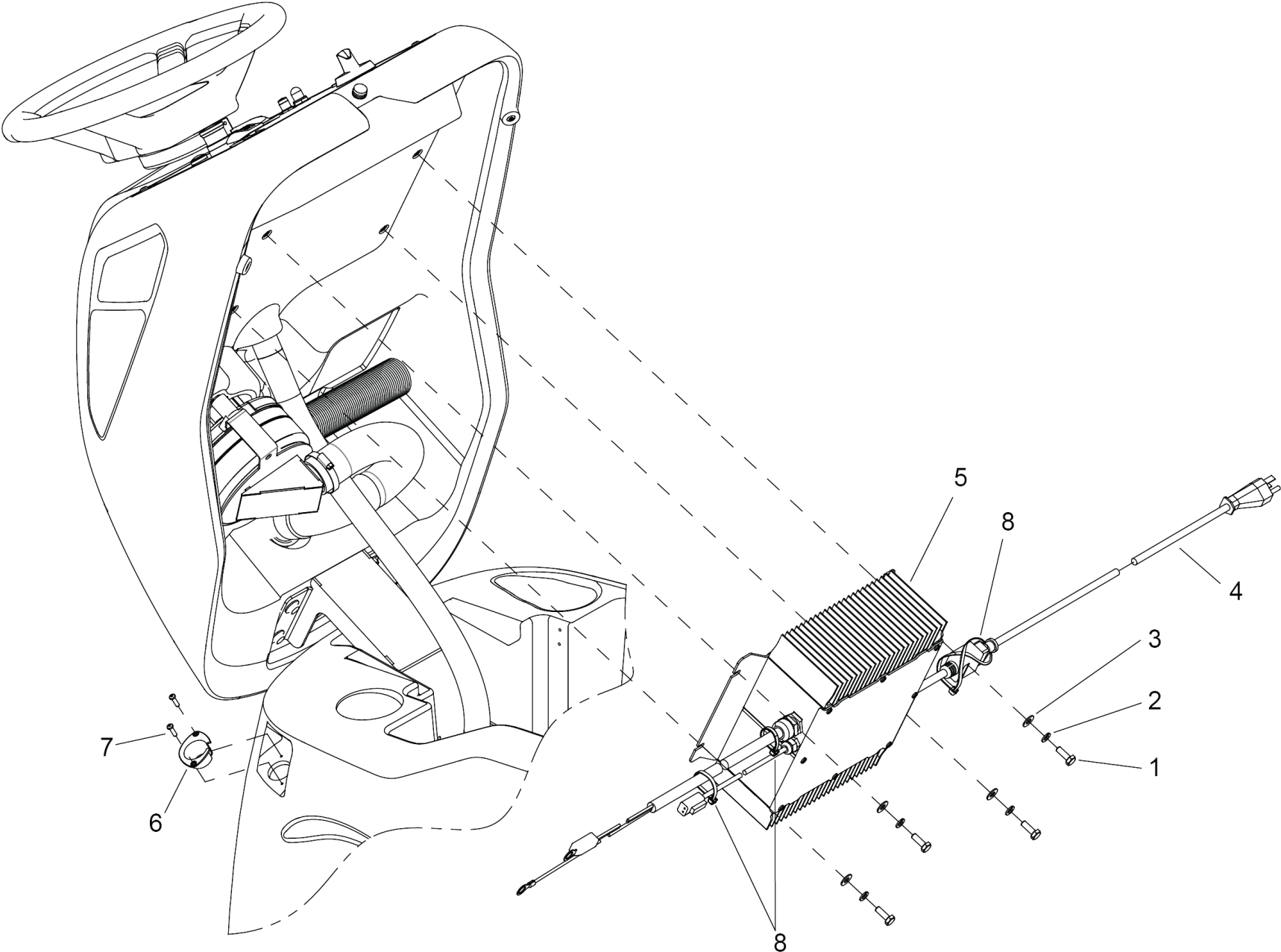

160 CHARGER - OPTIONAL

POS	Article no.	Description	Quantity	Unit
1	8.627-378.0	SCREW, 1/4-20 X .75 HHCS SS NP	4	PC
2	8.601-078.0	WASHER, 1/4 SPL STL ZNPLT	4	PC
3	8.601-063.0	WASHER, 1/4 SS	4	PC
4	8.623-439.0	CORD ASM, 16/3 SJTW X 2M IEC	1	PC
5	8.635-330.0	CHRGR, 36V 21A OBC ALG 1	1	PC
6	8.634-443.0	GROMMET, CHARGE PLUG	1	PC
7	8.617-314.0	SCREW, KA40 X 10 OVHCS STL WIN1412 ZNPLT	2	PC
8	8.626-494.0	Cable tie 11.38" UL/CSA	3	PC

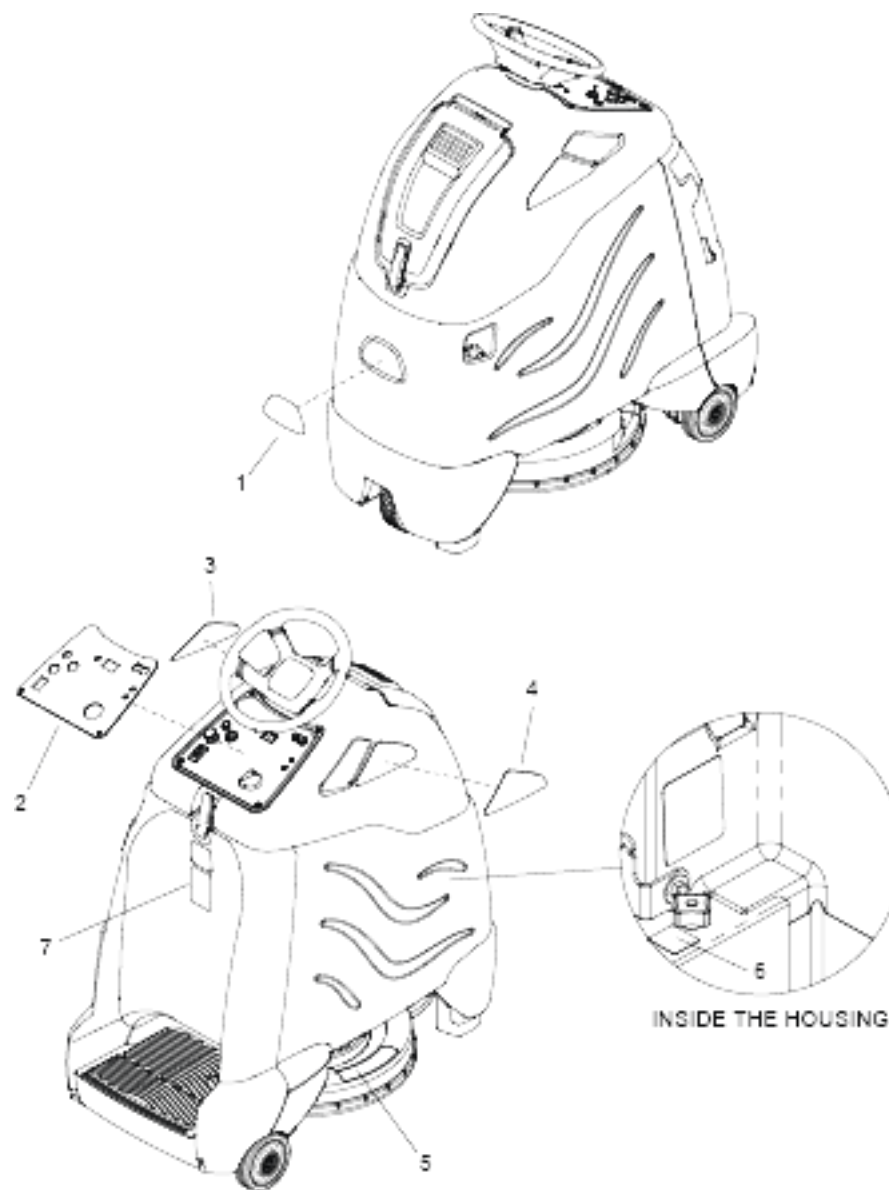

SEE SERIAL NUMBER PAGE FOR REFERENCE

170 DECALS

POS	Article no.	Description	Quantity	Unit	valid from
1	8.633-500.0	Label AKW domed logo	1	PC	
2	8.639-561.0	LABEL, PANEL, iGLOSS 20, DLX	1	PC	
		Item text1: ACTIVE MODELS			
2	8.639-562.0	LABEL, PANEL iGLOSS 20	1	PC	
		Item text1: PASSIVE MODELS			
3	8.639-563.0	LABEL, IGLOSS 20 LEFT	1	PC	
4	8.639-564.0	LABEL, IGLOSS 20 RIGHT	1	PC	
5	8.639-680.0	LABEL, BURNISHER SHROUD	1	PC	
6	8.638-508.0	LABEL, MANUAL	1	PC	(3*)
7	8.643-126.0	Label QR code iGloss 20	1	PC	

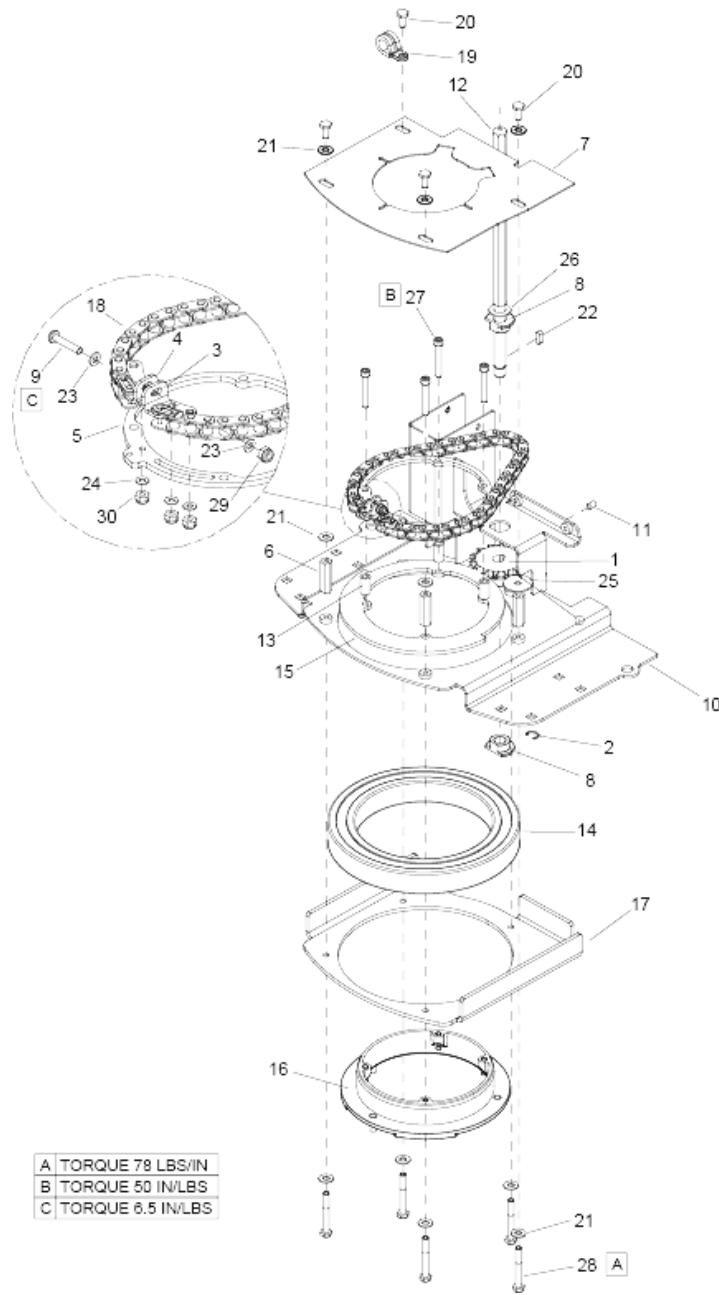

180 SLEW/STEERING-FROM SERIAL NUMBER (3*)

POS	Article no.	Description	Quantity	Unit
1	8.641-014.0	Gear wheel ANSI 40 14T	1	PC
2	8.640-964.0	Clip .50 SHAFT SIDE RETAIN	1	PC
3	8.640-957.0	Angle joint chain	1	PC
4	8.640-956.0	Angle joint chain	1	PC
5	8.640-955.0	Support plate chain	1	PC
6	8.640-952.0	Nut 1/4-20 X 1.5 CPL SS	4	PC
7	8.640-882.0	Plate chain guide C2	1	PC
8	8.640-864.0	Flanged bushing .503X1.25X.470 FLG 'D'	2	PC
9	8.640-858.0	Screw 10-32 X 1 TPNHMS SS BLK ZNPLT	1	PC
10	8.640-559.0	Support plate control system	1	PC
11	8.600-661.0	SCREW, 1/4-20 X .25 SCHSET KCP BLKOX	1	PC
12	8.640-556.0	SHAFT, STEERING SPROCKET	1	PC
13	8.640-551.0	Distance holder .25ID X .430OD X.83LG	4	PC
14	8.640-549.0	Bearing control system C2	1	PC
15	8.640-548.0	Plate C2	1	PC
16	8.640-547.0	Bearing screw connector bottom	1	PC
17	8.640-546.0	Plate c2	1	PC
18	8.640-534.0	Chain ANSI#40 X 21.5" W/2 MASTER	1	PC
19	8.636-387.0	CLAMP, 5/8" OD CUSHIONED	1	PC
20	8.627-383.0	SCREW, 1/4-20 X .5 HHCS SS NP	4	PC
21	8.601-063.0	WASHER, 1/4 SS	13	PC
22	8.632-671.0	KEY, 5 X 5 X 16MM CS GR1045	1	PC
23	8.627-919.0	WASHER, 10 FLT STL ZNPLT	2	PC
24	8.627-899.0	WASHER, 8 FLT	3	PC
25	8.627-894.0	WASHER, 1/4 STL ZNPLT	2	PC
26	8.627-885.0	WASHER, .506 X .94 X .06 NYL	1	PC
27	8.627-539.0	Screw 1/4-20 X 1.625 SCHCS STL ZNPLT	4	PC
28	8.627-385.0	SCREW, 1/4-20 X 2 HHCS SS	5	PC
29	8.627-099.0	NUT, 10-32 HEX NYLOCK SS	1	PC
30	8.627-085.0	Lock nut	3	PC

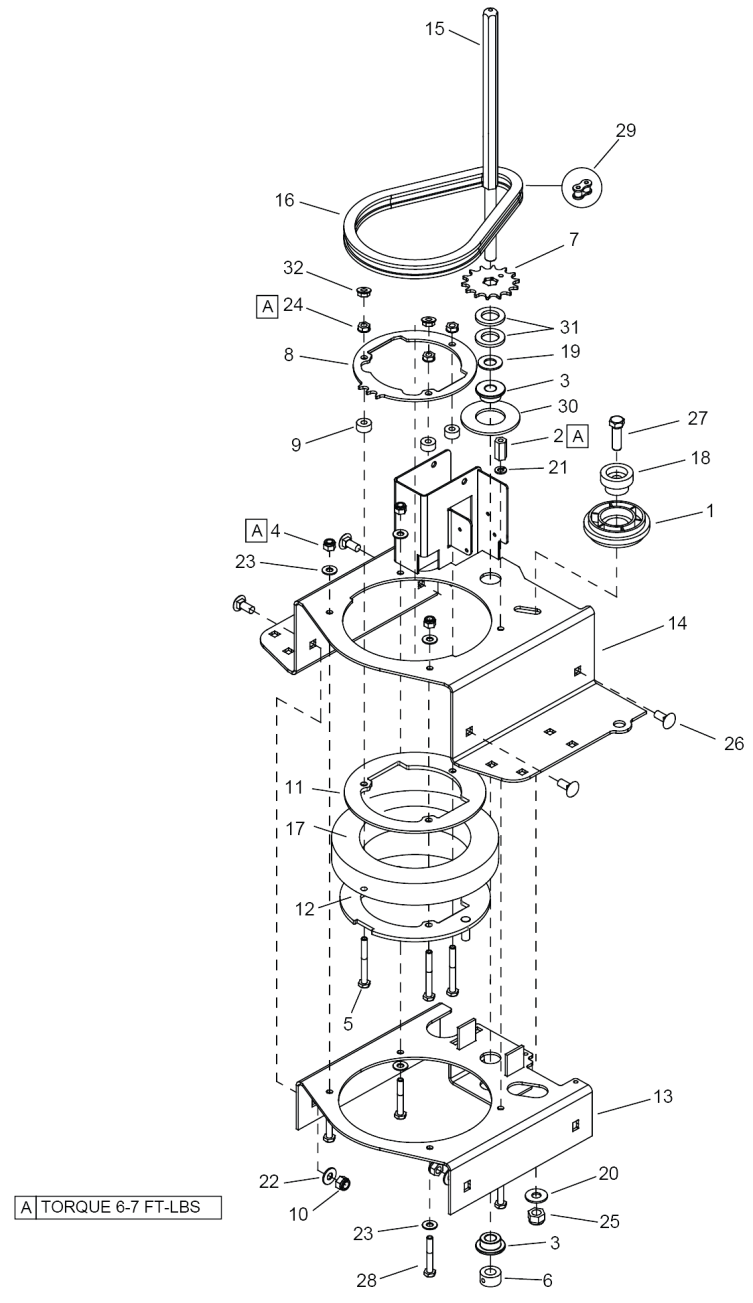

190 DRIVE-CHAIN PRIOR TO SERIAL NUMBER (3*)

POS	Article no.	Description	Quantity	Unit
1	8.633-072.0	CHAIN TENSIONNER	1	PC
2	8.632-935.0	NUT, 1/4-20 CPL SS	1	PC
3	8.632-805.0	BUSHING, .480 X 1.25 X .485 FLG	2	PC
4	8.627-187.0	NUT, 1/4-20 HEXTHIN NYLOCK SS	3	PC
5	8.627-310.0	SCREW, 1/4-20 X 2.25 HHCS STL GR5 ZNPLT	3	PC
6	8.632-206.0	COLLAR, 12MM ID	1	PC
7	8.632-205.0	SPROCKET, STEERING, 14T	1	PC
8	8.632-204.0	Retaining plate	1	PC
9	8.632-203.0	Spacer	3	PC
10	8.627-083.0	NUT, 5/16-18 HEX NYLOCK SS	7	PC
11	8.631-974.0	Plate bottom	1	PC
12	8.631-968.0	Plate above	1	PC
13	8.631-961.0	BRACKET, BEARING CLAMP	1	PC
14	8.631-960.0	BRACKET, DRIVE MOUNT	1	PC
15	8.631-959.0	SHAFT, STEERING SPROCKET	1	PC
16	8.631-956.0	CHAIN, ISO 08B, 12.7MM PITCH	1	PC
17	8.601-444.0	BEARING DRIVE	1	PC
18	8.622-427.0	SLEEVE, CHAIN TENSIONER	1	PC
19	8.625-943.0	WASHER, M12 FLT	1	PC
20	8.627-951.0	WASHER, 3/8 FLT STL ZNPLT	1	PC
21	8.601-078.0	WASHER, 1/4 SPL STL ZNPLT	1	PC
22	8.601-067.0	WASHER, 5/16 FLT SS	4	PC
23	8.601-063.0	WASHER, 1/4 SS	7	PC
24	8.600-571.0	NUT, 1/4-20 HEXSTRW LK STL ZNPLT	3	PC
25	8.627-193.0	NUT HEX NYL LOC 3/8-16	1	PC
26	8.627-607.0	SCREW, 5/16-18 X .75 CARR SS	4	PC
27	8.627-519.0	SCREW, 3/8-16 X 1.25 HHCS SS	1	PC
28	8.627-415.0	SCREW, 1/4-20 X 1.75 HHCS STL GR5 ZNPLT	4	PC
29	8.623-278.0	Chain MASTERLINK 12.7MM	1	PC
30	8.636-860.0	X-REF TO 8.632-656.0 8/16	1	PC
31	8.627-942.0	WASHER, .765 X 1.25 X .08 FLT NYL	2	PC
32	8.627-137.0	NUT, 1/4-20 SERFLG STL ZNPLT	2	PC

200 DRIVE LOWER - FROM SERIAL NUMBER (3*)

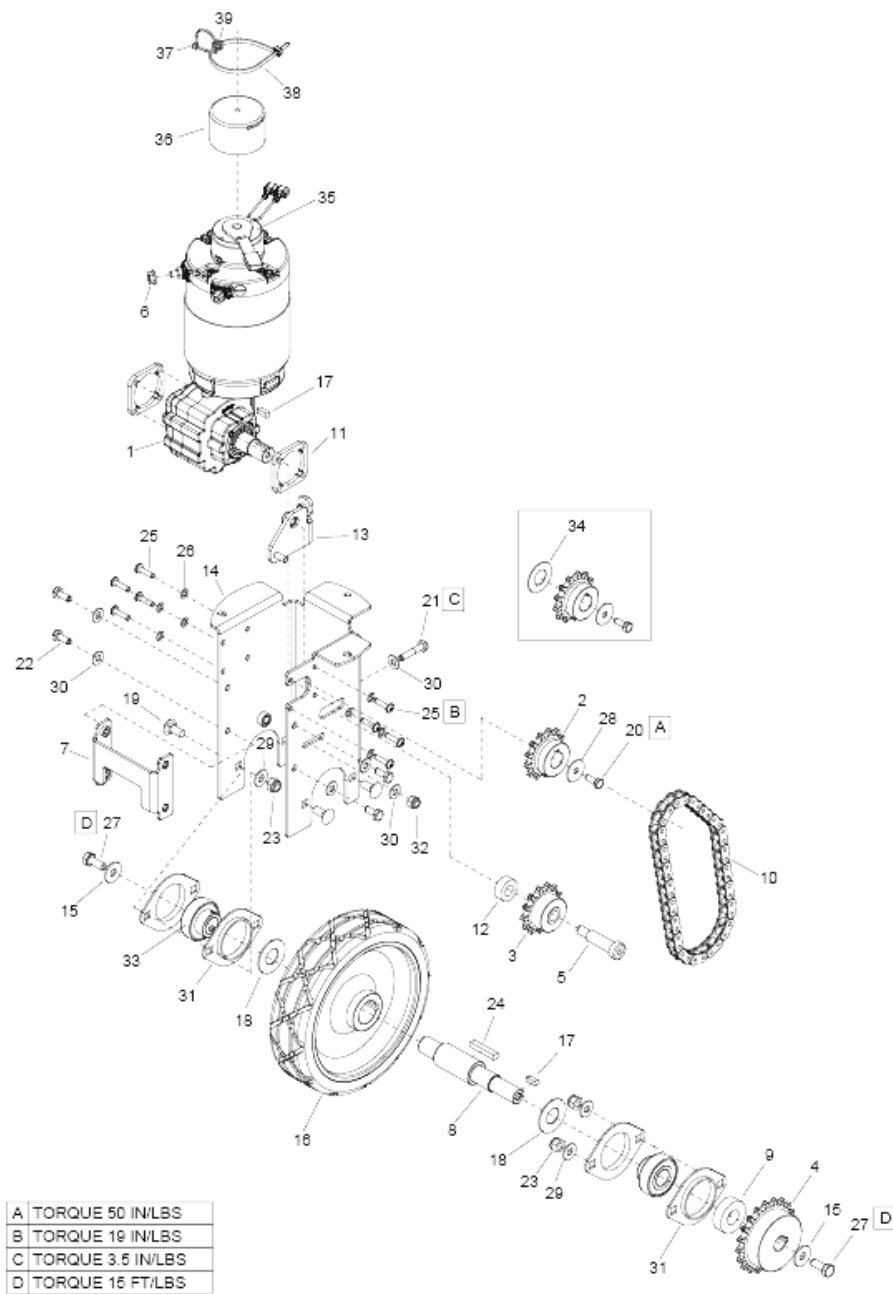

200 DRIVE LOWER - FROM SERIAL NUMBER (3*)

POS	Article no.	Description	Quantity	Unit	valid from
1	8.641-117.0	Traction motor C2	1	PC	(4*)
2	8.640-996.0	Chain wheel transmission ANSI 40 13T	1	PC	
3	8.640-995.0	Chain wheel transmission ANSI 40 13T IDLER	1	PC	
4	8.640-994.0	Chain wheel transmission ANSI 40 20T	1	PC	
5	8.640-591.0	Bolt 1/2 x 1.625	1	PC	
6	8.638-411.0	Nut M6-1, HEX, SERFLG, DIN6923	2	PC	
7	8.640-539.0	Retaining plate C2	1	PC	
8	8.640-538.0	Axle drive wheel	1	PC	
9	8.640-537.0	Distance holder C2	1	PC	
10	8.640-536.0	Chain ANSI#40 X 21" W/MASTER	1	PC	
11	8.640-535.0	Distance holder C2 MTR MNT HOUSING	2	PC	
12	8.640-533.0	Distance holder C2	1	PC	
13	8.640-532.0	Retaining plate C2	1	PC	
14	8.640-531.0	Housing transmission C2	1	PC	
15	7.312-289.0	Washer 8 -A2 ISO 7093-1	2	PC	
16	8.636-917.0	Wheel 8.00 x 2.00, GRAY X-GRV	1	PC	
17	8.632-671.0	KEY, 5 X 5 X 16MM CS GR1045	2	PC	
18	8.632-167.0	WASHER, .748 SS	2	PC	
19	8.627-607.0	SCREW, 5/16-18 X .75 CARR SS	4	PC	
20	8.627-470.0	Screw M6x1,0x16	1	PC	
21	8.627-462.0	SCREW, 1/4-20 X 1.25 HHMS STL GR5 ZNPLT	1	PC	
22	8.627-375.0	SCREW, 1/4-20 X .625 HHCS SS NP	4	PC	
23	8.627-083.0	NUT, 5/16-18 HEX NYLOCK SS	4	PC	
24	8.621-964.0	KEY, 1/4 X 1/4 X 1.5 LCSTL GR1018	1	PC	
25	8.638-412.0	Screw M5-0.8 X 16, TPNHMSSS	8	PC	
26	8.613-733.0	WASHER, M5 SHPRF STL ZNPLT	8	PC	
27	8.613-664.0	SCREW, M8-1.25 X 20 HHMS ZNPLT	2	PC	
28	8.601-081.0	WASHER, 1/4 FNDR SS	1	PC	
29	8.601-067.0	WASHER, 5/16 FLT SS	4	PC	
30	8.601-063.0	WASHER, 1/4 SS	6	PC	
31	8.600-861.0	Flanged bearing PRESS STEEL	4	PC	
32	8.627-187.0	NUT, 1/4-20 HEXTHIN NYLOCK SS	1	PC	
33	8.600-103.0	BEARING, 3/4 SPH BALL	2	PC	

200 DRIVE LOWER - FROM SERIAL NUMBER (3*)

POS	Article no.	Description	Quantity	Unit	valid from
34	8.640-554.0	Spacer sleeve C2	1	PC	
35	8.638-691.0	Brake traction motor C2	1	PC	
36	8.642-686.0	Environmental brake cover	1	PC	(6*)
37	8.626-493.0	CABLE TIE, 3.5" UL/CSA	1	PC	(7*)
38	8.626-494.0	Cable tie 11.38" UL/CSA	1	PC	(7*)
39	8.638-441.0	Cable spacer cross	1	PC	(7*)

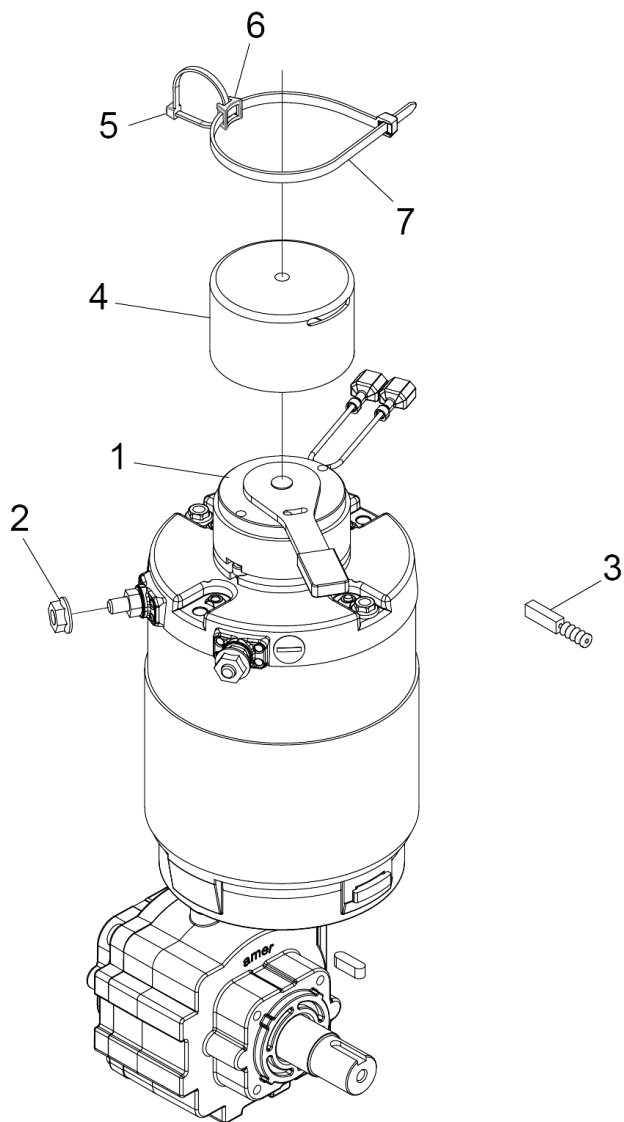

1 Traction motor C2 (8.641-117.0)

POS	Article no.	Description	Quantity	Unit
1	8.638-691.0	Brake traction motor C2	1	PC
2	8.638-411.0	Nut M6-1, HEX, SERFLG, DIN6923	2	PC
3	8.638-409.0	Carbon brush set AOMPI40	1	PC
4	8.642-686.0	Environmental brake cover	1	PC
5	8.626-493.0	CABLE TIE, 3.5" UL/CSA	1	PC
6	8.631-441.0	RELEASE BUTTON	1	PC
7	8.626-494.0	Cable tie 11.38" UL/CSA	1	PC

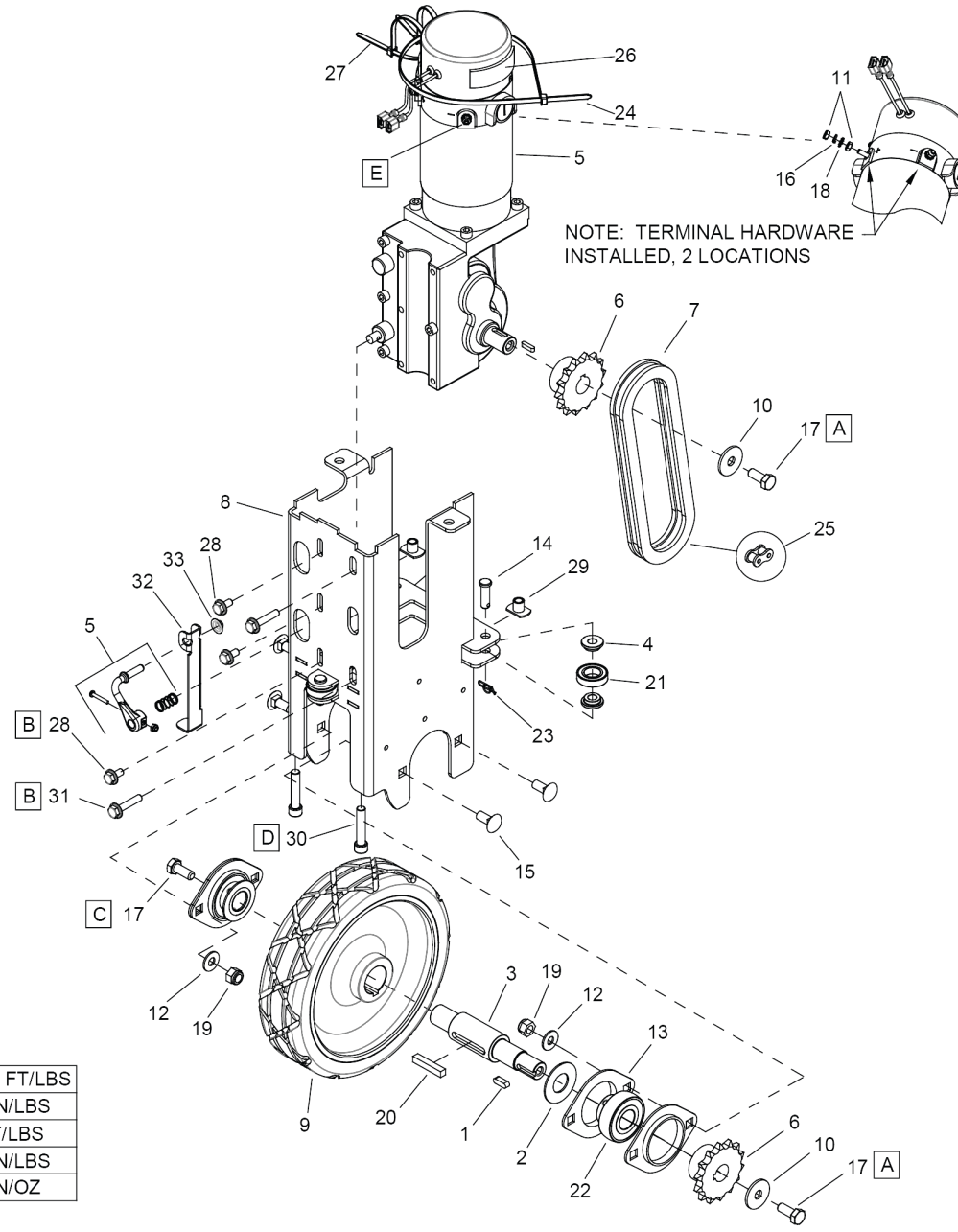

210 DRIVE-LOWER PRIOR TO SERIAL NUMBER (3*)

POS	Article no.	Description	Quantity	Unit
1	8.632-671.0	KEY, 5 X 5 X 16MM CS GR1045	1	PC
2	8.632-167.0	WASHER, .748 SS	2	PC
3	8.631-981.0	Axle drive wheel	1	PC
4	8.631-967.0	SLEEVE, BEARING	6	PC
5	8.636-401.0	Wheel drive motor	1	PC
	Item text1: For installation of 8.636-401.0			
	Item text2: order kit 8.636-900.0			
5		KIT, BRAKE REPLACEMENT - SMALL STAND ON	1	PC
	Item text1: NOT SHOWN			
5	8.637-844.0	Carbon brush set traction motor	1	PC
	Item text1: NOT SHOWN - CCL motor use 8.633-199.0			
	Item text2: Linix motor use 8.637-841.0			
6	8.631-965.0	SPROCKET, DRIVE, 14T	2	PC
7	8.631-964.0	CHAIN, ISO 08B, 12.7MM PITCH	1	PC
8	8.631-962.0	Frame transmission	1	PC
9	8.636-917.0	Wheel 8.00 x 2.00, GRAY X-GRV	1	PC
10	8.627-963.0	WASHER, 5/16 X 1.13 X .09 FLT	3	PC
11	8.628-850.0	NUT, M4X.7 HEX STL CL8 ZNPLT	4	PC
12	8.601-067.0	WASHER, 5/16 FLT SS	4	PC
13	8.600-861.0	Flanged bearing PRESS STEEL	4	PC
14	8.627-255.0	PIN, CLEVIS 5/16 X 1 STL ZNPLT	3	PC
15	8.627-607.0	SCREW, 5/16-18 X .75 CARR SS	4	PC
16	8.613-485.0	WASHER, M4 SPRL SS DIN127B	2	PC
17	8.613-664.0	SCREW, M8-1.25 X 20 HHMS ZNPLT	3	PC
18	8.637-223.0	WASHER, M4 EXTLK STL DIN6797 TYPEA ZNPLT	2	PC
19	8.627-083.0	NUT, 5/16-18 HEX NYLOCK SS	4	PC
20	8.621-964.0	KEY, 1/4 X 1/4 X 1.5 LCSTL GR1018	1	PC
21	8.633-238.0	ROLLER, 1.1 OD	3	PC
22	8.600-103.0	BEARING, 3/4 SPH BALL	2	PC
23	8.600-866.0	Cotter 5/16" RING	3	PC
24	8.600-283.0	Cable tie .375 X 24.7	1	PC
25	8.623-278.0	Chain MASTERLINK 12.7MM	1	PC
	Item text1: NOT SHOWN			

210 DRIVE-LOWER PRIOR TO SERIAL NUMBER (3*)

POS	Article no.	Description	Quantity	Unit
26	8.636-204.0	TAPE CLOSED CELL 1/8 X 3/4 X 2 1/2 PSA	2	PC
27	8.626-492.0	CABLE TIE, 7" UL/CSA	2	PC
28	8.636-214.0	SCREW, M6-1 X 12 HEXFLGHSERFLG STL ZNPLT	3	PC
29	8.634-849.0	NUT, 5/16-18 X .38 WLD TAB STL	2	PC
30	8.636-213.0	SCREW, 5/16-18 X 1.5 SCHCS SS	2	PC
31	8.636-215.0	SCREW, M6-1 X 30 HEXFLGHSERFLG STL ZNPLT	2	PC
32	8.633-387.0	LEVER, DRIVE ENGAGEMENT	1	PC
33	8.627-124.0	NUT, 1/4 PAL STL ZNPLT	1	PC

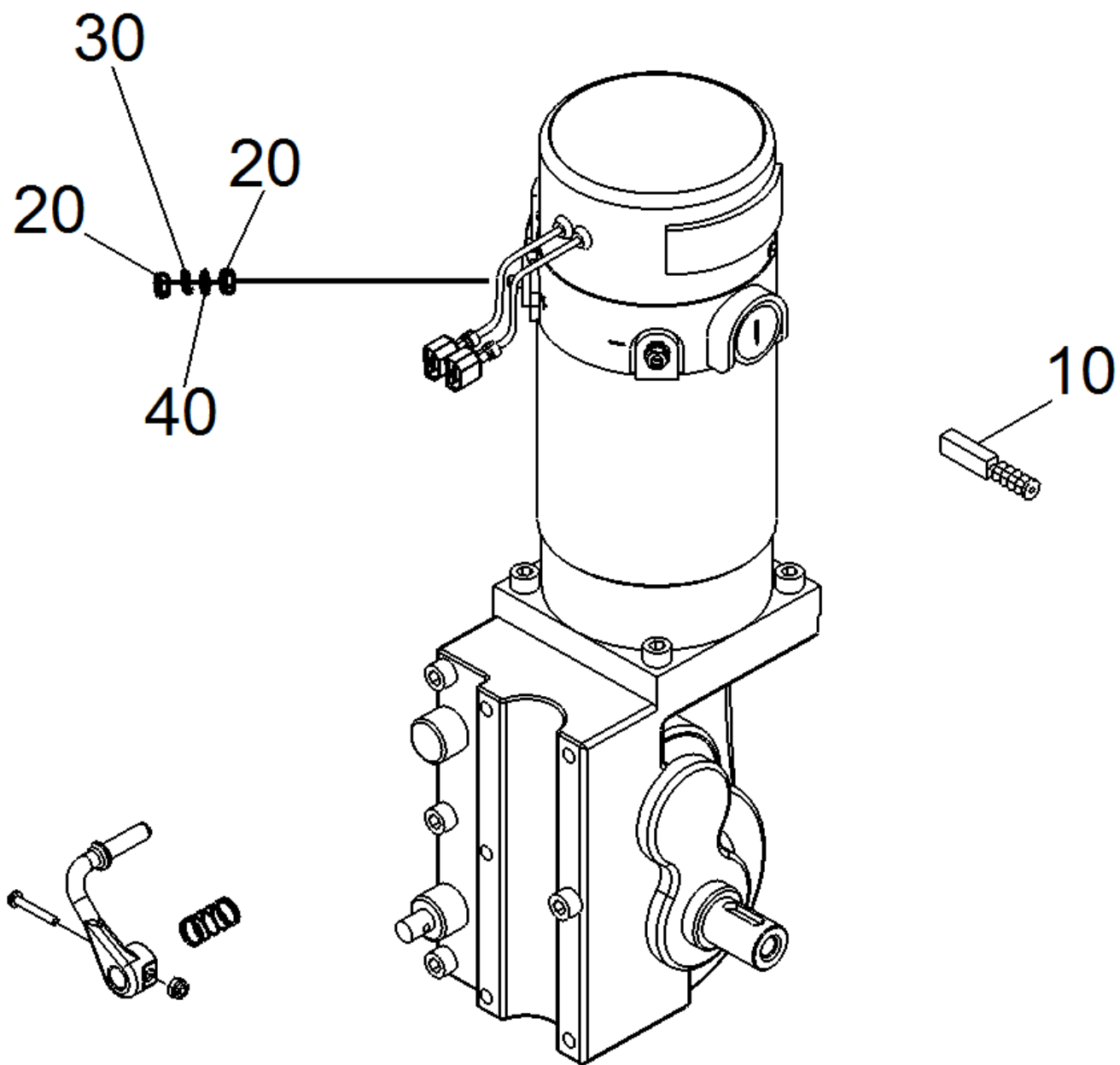

5 Wheel drive motor (8.636-401.0)

POS	Article no.	Description	Quantity	Unit
10	8.637-844.0	Carbon brush set traction motor	1	PC
20	8.628-850.0	NUT, M4X.7 HEX STL CL8 ZNPLT	4	PC
30	8.613-485.0	WASHER, M4 SPRL SS DIN127B	2	PC
40	8.637-223.0	WASHER, M4 EXTLK STL DIN6797 TYPEA ZNPLT	2	PC

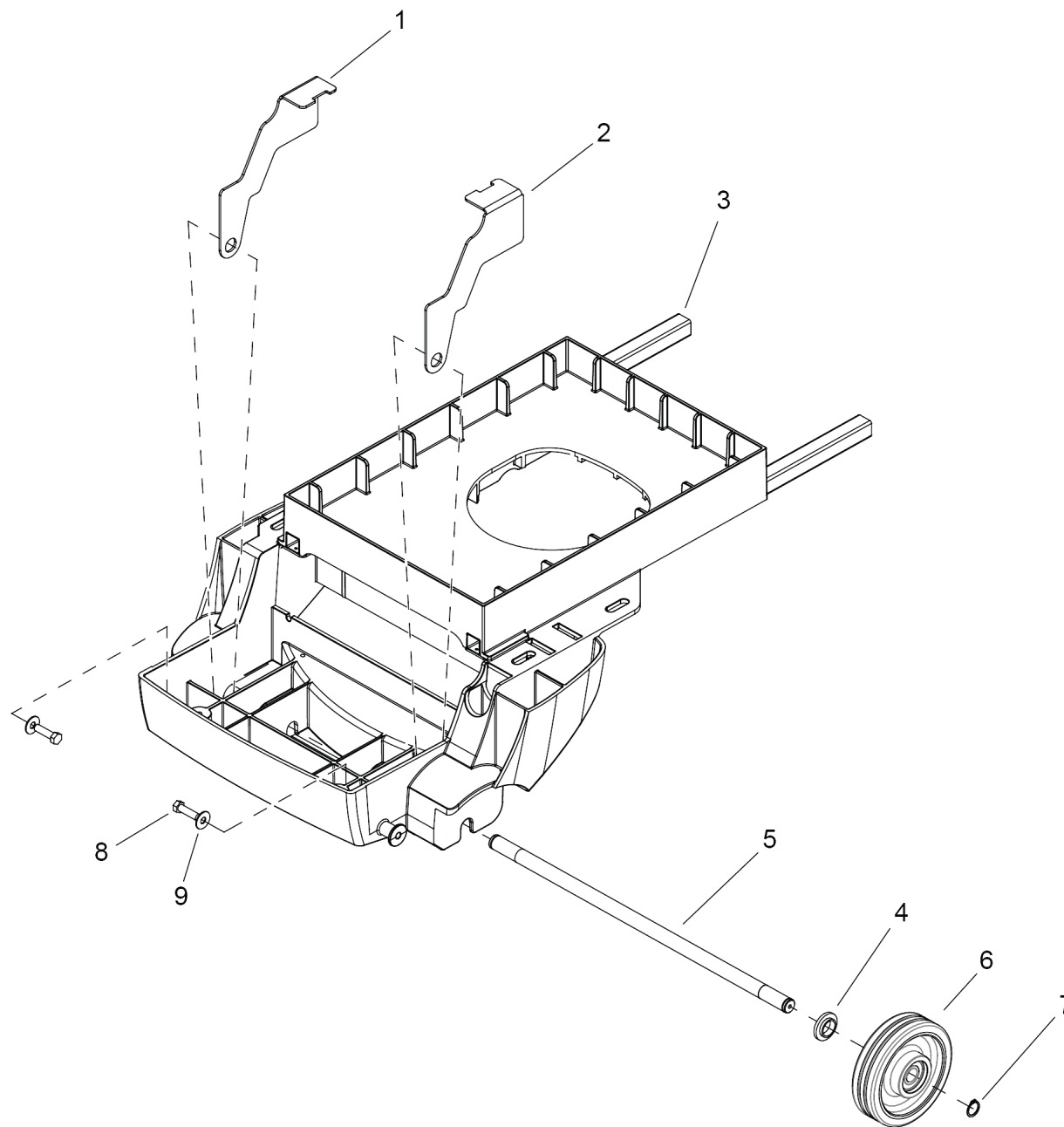

220 FRAME & REAR WHEELS

POS	Article no.	Description	Quantity	Unit
1	8.632-626.0	Holder frame left	1	PC
2	8.632-625.0	Holder frame right	1	PC
3	8.636-850.0	FRAME ASM, BLK	1	PC
	Item text1: INCLUDES ITEM 8 & 9			
4	8.632-622.0	SPACER, FLG, .887ID X 1.055OD X .345LG	2	PC
5	8.631-803.0	AXLE, 20MM X 562MM	1	PC
6	8.636-916.0	WHEEL, 6.00X1.58, GRY W/BEARINGS	2	PC
7	8.622-347.0	RING, 20MM EXTERNAL SNAP	2	PC
8	8.627-891.0	WASHER, 3/8 SS	2	PC
9	8.634-095.0	SCREW, 3/8 X 1.5 HHLS STL ZNPLT	2	PC

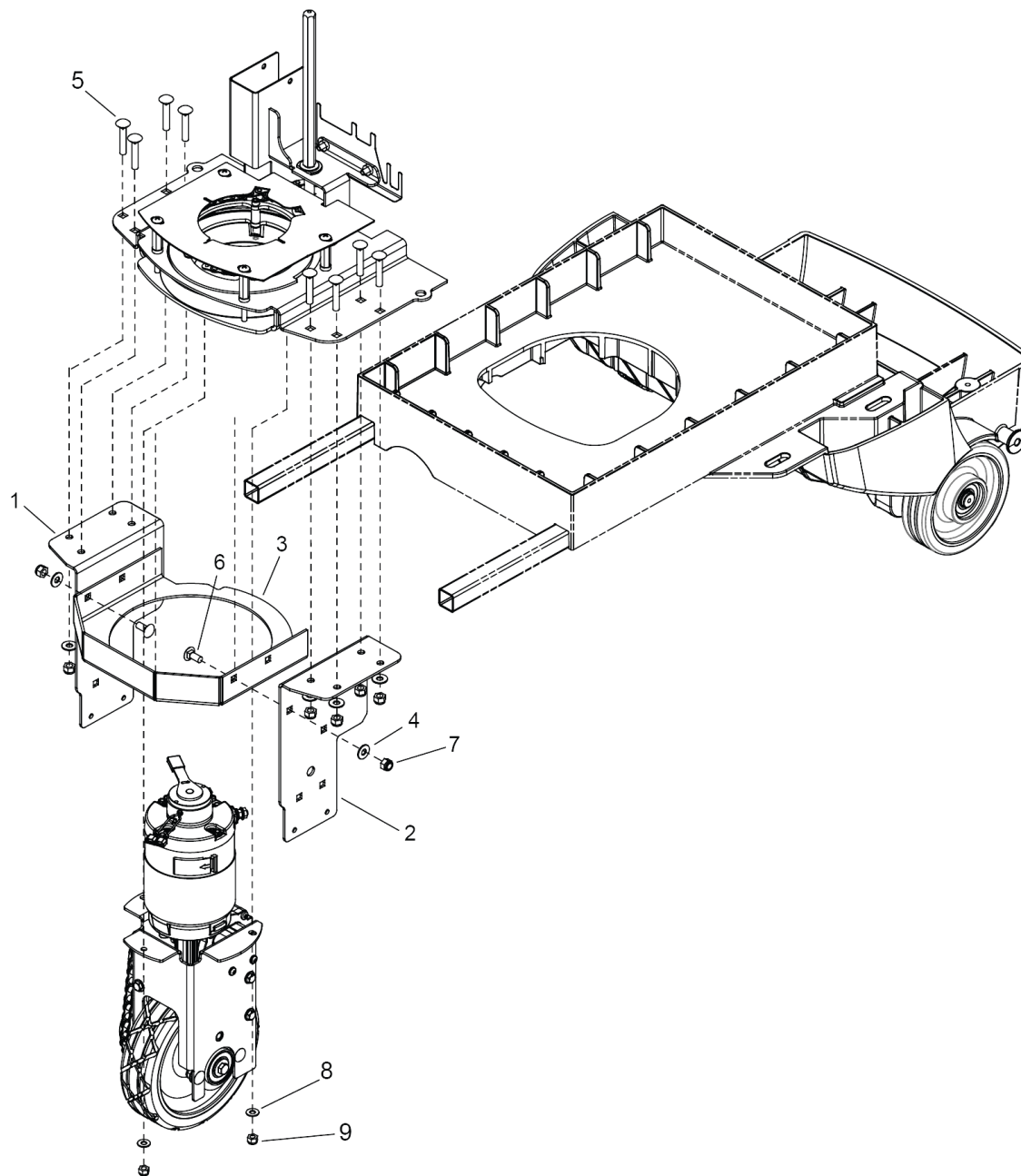

230 DRIVE MOUNTING - FROM SERIAL NUMBER (3*)

POS	Article no.	Description	Quantity	Unit
1	8.634-462.0	BRACKET, LINKAGE MOUNT	1	PC
2	8.631-973.0	Sheet metal component left	1	PC
3	8.640-541.0	BRACKET, C2 LOWER SUPPORT	1	PC
4	8.601-067.0	WASHER, 5/16 FLT SS	10	PC
5	8.627-669.0	SCREW, 5/16-18 X 1.75 CARR SS	8	PC
6	8.627-607.0	SCREW, 5/16-18 X .75 CARR SS	2	PC
7	8.627-083.0	NUT, 5/16-18 HEX NYLOCK SS	10	PC
8	8.601-063.0	WASHER, 1/4 SS	3	PC
9	8.627-187.0	NUT, 1/4-20 HEXTHIN NYLOCK SS	3	PC

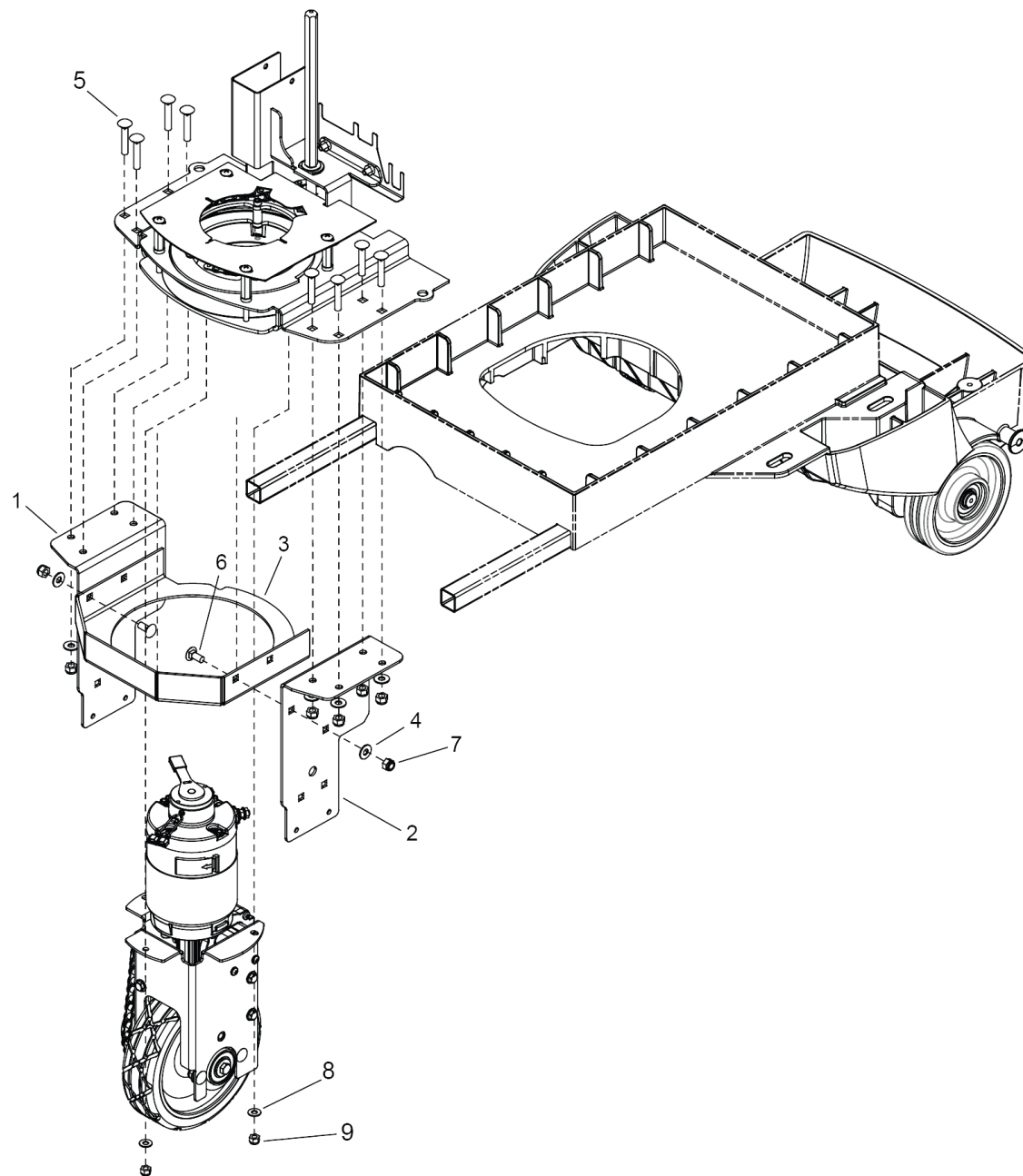

240 DRIVE MOUNTING - PRIOR TO SN (3*)

POS	Article no.	Description	Quantity	Unit
1	8.634-462.0	BRACKET, LINKAGE MOUNT	1	PC
2	8.631-973.0	Sheet metal component left	1	PC
3	8.633-163.0	BRACKET, ROLLER GUIDE	1	PC
4	8.601-067.0	WASHER, 5/16 FLT SS	12	PC
5	8.627-669.0	SCREW, 5/16-18 X 1.75 CARR SS	8	PC
6	8.627-607.0	SCREW, 5/16-18 X .75 CARR SS	2	PC
7	8.627-083.0	NUT, 5/16-18 HEX NYLOCK SS	12	PC
8	8.627-476.0	SCREW, 1/4-20 X .5 HHCS STL GR5 ZNPLT	1	PC
9	8.636-387.0	CLAMP, 5/8" OD CUSHIONED	1	PC
10	8.632-934.0	Plate protection	1	PC
11	8.627-894.0	WASHER, 1/4 STL ZNPLT	1	PC

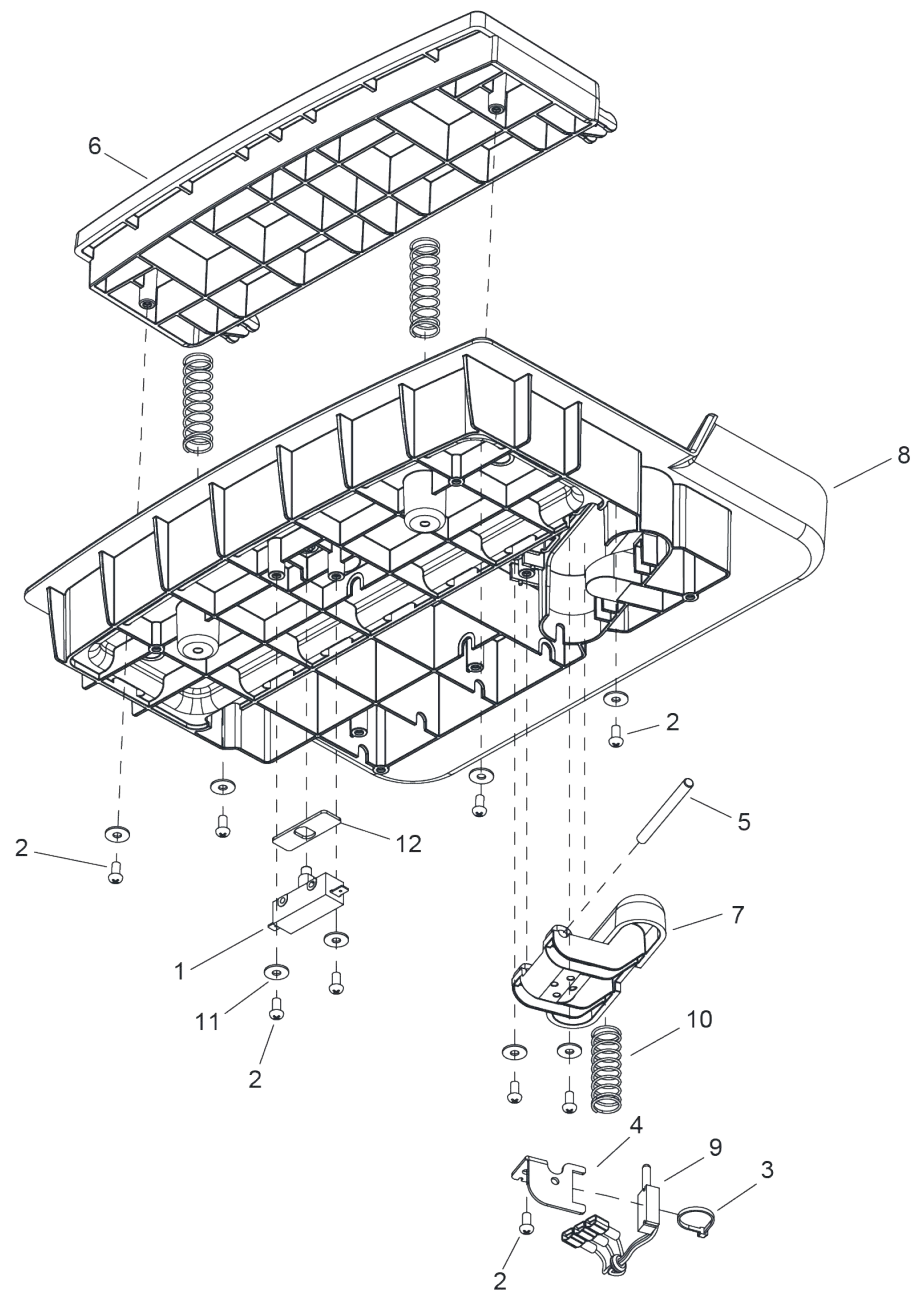

250 PEDAL PLATFORM

POS	Article no.	Description	Quantity	Unit
1	8.600-711.0	Switch 25A SPST 125-250V SNAP	1	PC
2	8.617-298.0	SCREW, KA50 X 10 OVHCS STL WN1412 ZNPLT	9	PC
3	8.626-493.0	CABLE TIE, 3.5" UL/CSA	1	PC
4	8.632-615.0	BRKT, LINEAR POT	1	PC
5	8.632-614.0	PIN, DOWEL 1/4 X 2.75 STL	1	PC
6	8.633-424.0	PEDAL, HEEL, BLK	1	PC
7	8.633-469.0	PEDAL, ACCELERATOR, YEL	1	PC
8	8.633-423.0	Moulded part black	1	PC
9	8.631-156.0	POTENTIOMETER ASM, LINEAR	1	PC
10	8.625-497.0	SPRING, COMP 18MMOD X 83 X 2	3	PC
11	8.617-333.0	WASHER, M5 SS ISO7093	8	PC
12	8.645-248.0	SWITCH SPACER PLATE	1	PC

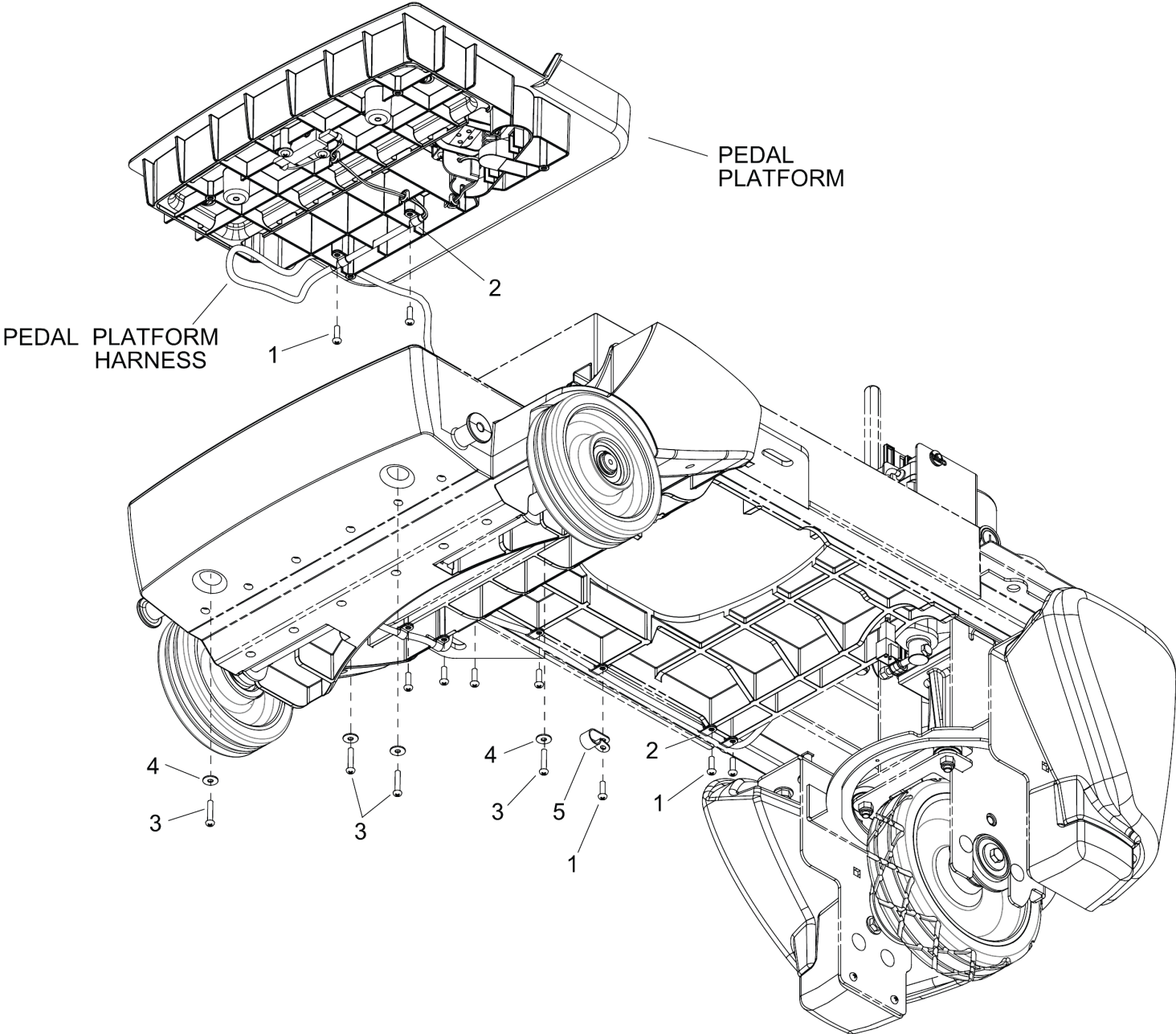

260 PEDAL PLATFORM MOUNTING

POS	Article no.	Description	Quantity	Unit
1	7.303-104.0	Screw 5x16 -A2-70 (IN6RD)	9	PC
2	8.619-844.0	CLAMP, 1/4 PLASTIC CABLE	9	PC
3	8.632-791.0	SCREW, KA50 X 25 PTOVHS STL WN1412 ZNPLT	4	PC
4	8.617-333.0	WASHER, M5 SS ISO7093	4	PC
5	8.619-847.0	Clamp 9/16 DIA NYLON	1	PC

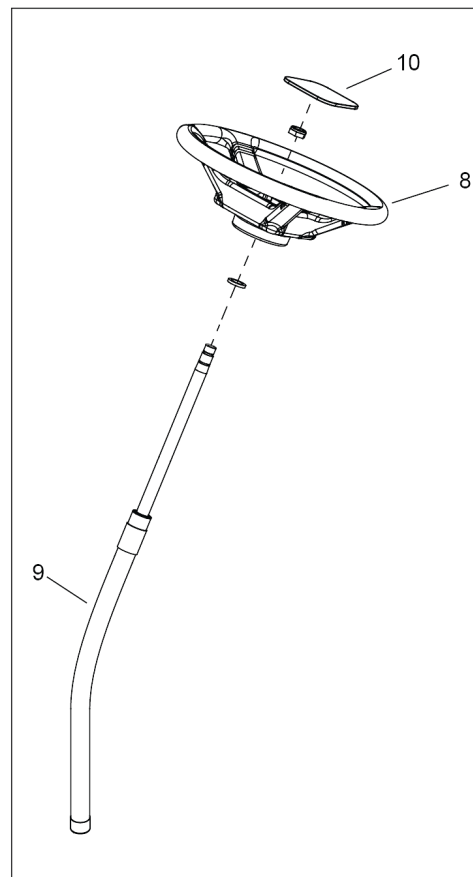
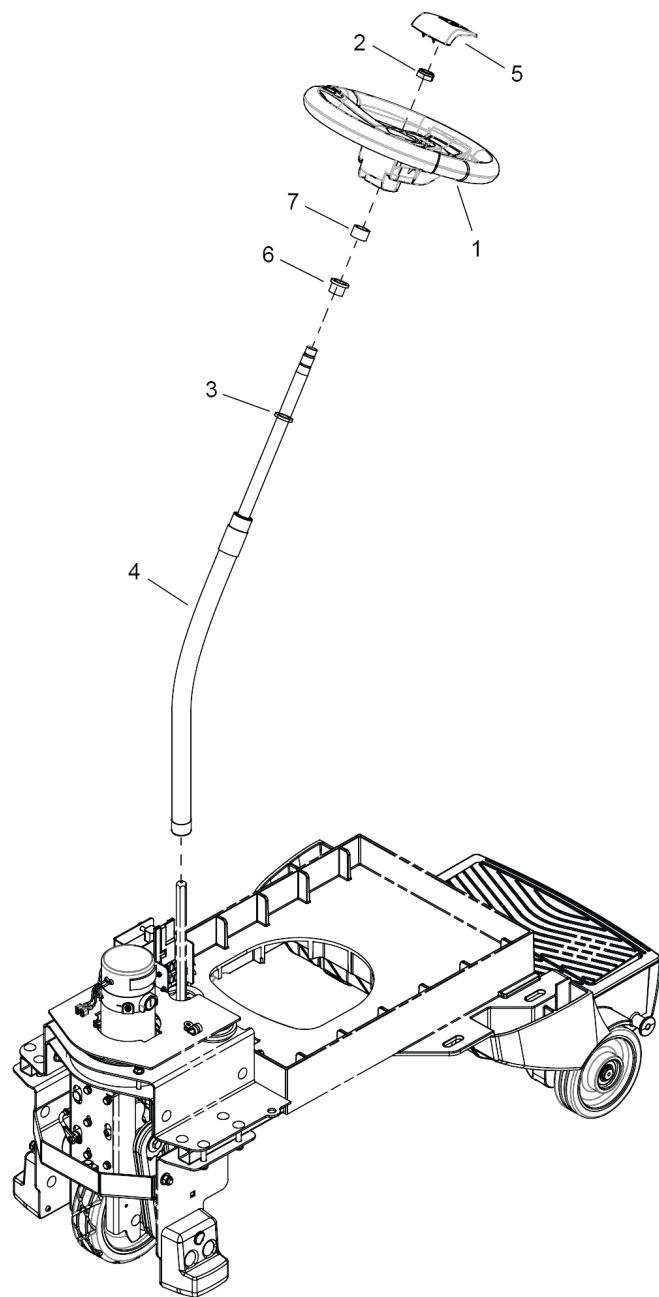

270 STEERING

POS	Article no.	Description	Quantity	Unit
1	6.435-799.0	Steering wheel	1	PC
2	8.627-161.0	NUT, 5/8-18 HEXTHIN NYLOCK STL GR2 ZNPLT	1	PC
3	8.627-942.0	WASHER, .765 X 1.25 X .08 FLT NYL	1	PC
4	8.635-569.0	Steering shaft	1	PC
	Item text1: COMPLETE			
5	6.640-353.0	Cap steering wheel KÄRCHER	1	PC
6	8.622-879.0	BUSHING, .753 X .875 X .75 FLG	2	PC
7	8.633-395.0	BUSHING, .751 D X 1 X .625 FLG	1	PC
8	8.625-961.0	Wheel STEERING 40 SPLINE HUB	1	PC
9	8.637-837.0	ASM, SHAFT, STEERING, CHARIOT 2	1	PC
10	8.623-481.0	Cover steering wheel	1	PC

280 VACUUM - OPTIONAL

POS	Article no.	Description	Quantity	Unit
1	8.627-392.0	SCREW, 1/4-20 X 1.75 PHPNHMS SS	3	PC
2	8.601-063.0	WASHER, 1/4 SS	3	PC
3	8.635-329.0	BRACKET, MOUNTING, VAC MOTOR	1	PC
4	8.631-292.0	GASKET, VAC MOTOR	1	PC
5	6.490-197.3	Turbine 2-level 36V 650W (CCL)	1	PC
6	8.626-494.0	Cable tie 11.38" UL/CSA	1	PC
7	8.632-750.0	BUSHING, .250 X .75 X 1 MOUNT VIBRATION	3	PC
8	8.600-240.0	Clamp 2.0" WORM GEAR X .312W	1	PC
9	8.632-033.0	HOSE ASM, 1.5 BLK VAC X12	1	PC
10	8.635-615.0	HOSE, 1.5" X 7.75", 4:1 STRETCH	1	PC
11	8.629-122.0	SCREW, KA40 X 16 FLT SS WN1413	2	PC
12	8.635-591.0	CLIP, 1-3/4", PLASTIC	1	PC
13	8.614-333.0	MOTOR FILTER U19836	1	PC
14	8.635-465.0	FRAME, FILTER	1	PC
15	8.627-764.0	SCREW, 1/4-20 X .75 PHTRHMS SS	2	PC

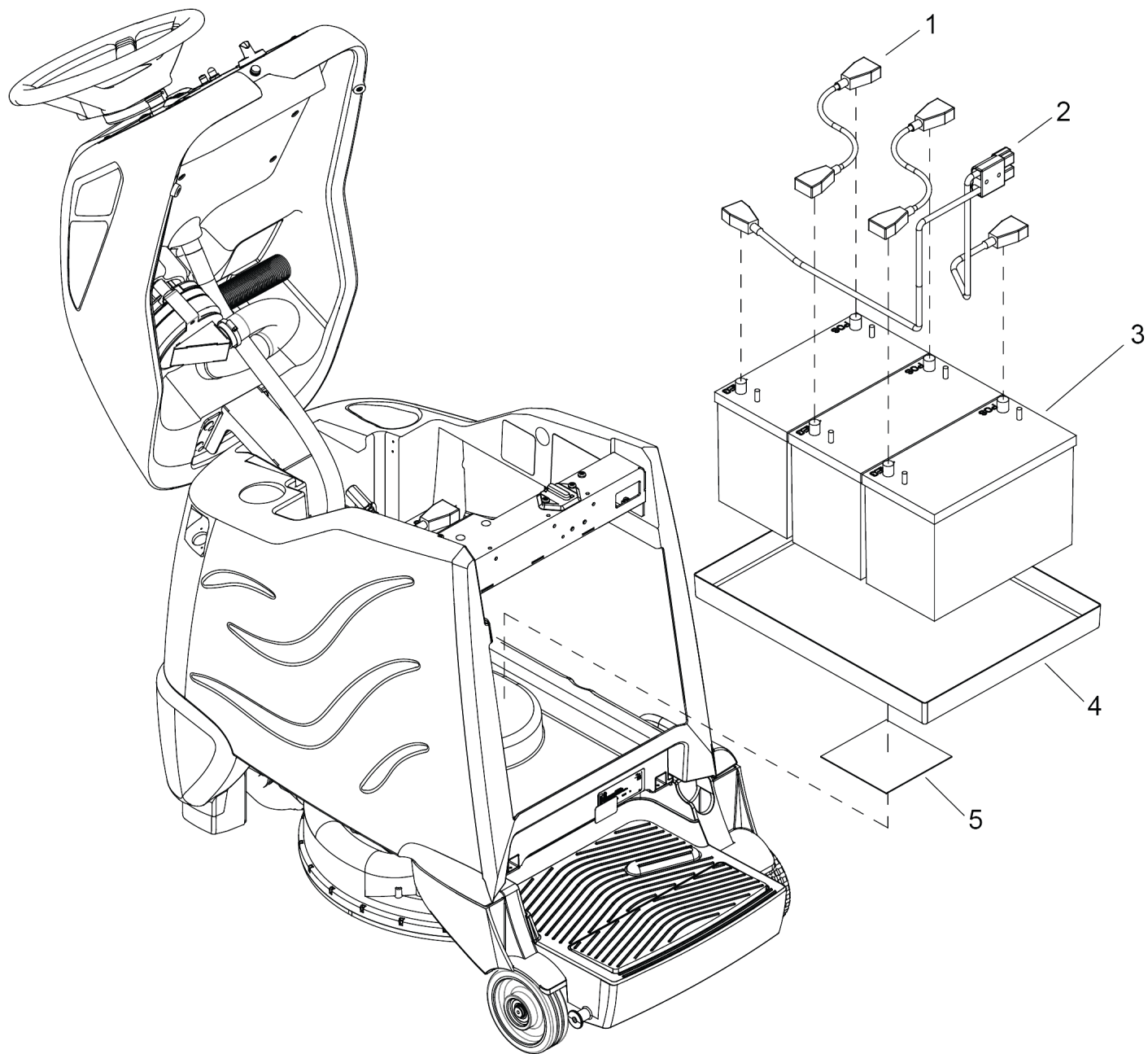

290 WIRING - BATTERY

POS	Article no.	Description	Quantity	Unit
1	8.632-972.0	Cable battery	2	PC
2	8.635-612.0	CABLE, ASM, BATTERY	1	PC
3	8.622-840.0	BATTERY, 12V, 130AH (30XHS)	3	PC
3	8.622-843.0	BATTERY, 12V AGM 234AH	3	PC
	Item text1: NOT SHOWN			
3	8.628-341.0	BATTERY, 12V, 225AH (J185H-AC)	3	PC
	Item text1: NOT SHOWN			
3	8.632-863.0	BATTERY, 12V 114A/H AGM	3	PC
	Item text1: NOT SHOWN			
4	8.639-531.0	Tub battery	1	PC
	Item text1: REQD. WITH 86283410 & 86228430			
5	8.635-955.0	TAPE, 1/16" T X 6.0" SQ. 2 SIDE ADH	1	PC

Serial Numbers

REF. NO.	MODEL: SERIAL #
1	10020310000177, 10020320000095, 10020330000083, 10020340000053, 10020350000188, 10020360100300
2	10020310000181, 10020320000100, 10020330000092, 10020340000056, 10020350000196, 10020360100317
3	10020310000235, 10020320000158, 10020330000114, 10020340000082, 10020350000220, 10020360100357
4	10020310000244, 10020320000158, 10020330000114, 10020340000085, 10020350000227, 10020360100360
5	10020310000280, 10020320000163, 10020330000137, 10020340000112, 10020350000271, 10020360100459
6	10020310000349, 10020320000253, 10020330000148, 10020340000130, 10020350000337, 10020360100557
7	10020310000369, 10020320000275, 10020330000153, 10020340000144, 10020350000358, 10020360100591

If you see a ref number with an (*) in either the "Serial number from" column or "Serial number to" column in a parts list, it is referring to the serial numbers with the corresponding ref number in this serial number list.

The serial number indicates the first machine the part number is applicable to. The main illustration shows the most current design of the machine. When a boxed illustration is shown, it displays the older design.

9020 Chariot iGloss 20 Serial Numbers

POS	Description	Quantity	Unit
10	SERIAL NUMBER PAGE	1	PC