

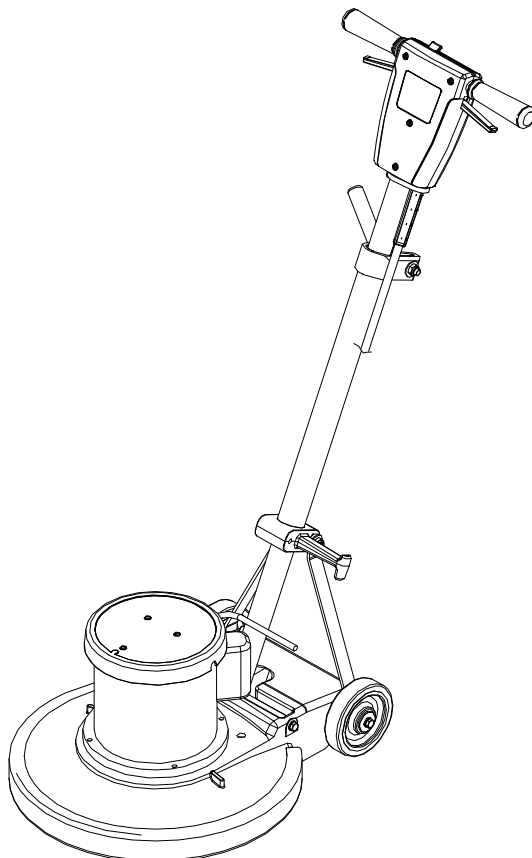

FLOOR POLISHER



MODELS:

BDS 43/175 C-10090710

BDS 51/175 C-10090720

BDS 51/175-300 C-10090700



Operating Instructions (ENG)



 **CLICK TO ORDER PARTS**

MACHINE DATA LOG/OVERVIEW

Model: _____

Date of Purchase: _____

Serial Number: _____

Sales Representative: _____

Address: _____

Phone Number: _____

TABLE OF CONTENTS

Machine Data Log.....2
Table of Contents.....3

HOW TO USE THIS MANUAL

How to use this Manual..... 1-1

SAFETY

Important Safety Instructions2-1
Hazard Intensity Level.2-2
Grounding Instructions 120V.2-3
Safety Label Location2-4

OPERATION

Technical Specifications3-1
Handle Installation3-2
Controls.....3-3
Handle Adjustment.....3-3
Machine Operation.....3-4
Pad Driver Installation.....3-4

MAINTENANCE

Scrub Brush/Pads4-1
Machine Troubleshooting.....4-2

GROUP PARTS LIST

Brush/Pad Driver Group.....5-1
Electrical – 120v.....5-3
Deck.....5-5
Handle.....5-7
Motor.....5-9
Wiring-120V5-11
Suggested Spare Parts.....5-12

HOW TO USE THIS MANUAL

This manual contains the following sections:

- HOW TO USE THIS MANUAL
- SAFETY
- OPERATIONS
- MAINTENANCE
- PARTS LIST

The HOW TO USE THIS MANUAL section will tell you how to find important information for ordering correct repair parts.

Parts may be ordered from authorized dealers. When placing an order for parts, the machine model and machine serial number are important. Refer to the MACHINE DATA box which is filled out during the installation of your machine. The MACHINE DATA box is located on the inside of the front cover of this manual.

Model:	_____
Date of Purchase:	_____
Serial Number:	_____
Sales Representative:	_____
Address:	_____
Phone Number:	_____

The SAFETY section contains important information regarding hazard or unsafe practices of the machine. Levels of hazards are identified that could result in product or personal injury, or severe injury resulting in death.

The OPERATIONS section is to familiarize the operator with the operation and function of the machine.

The MAINTENANCE section contains preventive maintenance to keep the machine and its components in good working condition. They are listed in this general order:

The PARTS LIST section contains assembled parts illustrations and corresponding parts list. The parts lists include a number of columns of information:

- **REF** – column refers to the reference number on the parts illustration.
- **PART NO.** – column lists the part number for the part.
- **PRV NO.** - Reference No.
- **QTY** – column lists the quantity of the part used in that area of the machine.
- **DESCRIPTION** – column is a brief description of the part.
- **SERIAL NO. FROM** – If this column has an (*) and a Reference number, see the SERIAL NUMBERS page in the back of your manual. If column has two asterisk (**), call manufacturer for serial number. The serial number indicates the first machine the part number is applicable to. The main illustration shows the most current design of the machine. When a boxed illustration is shown, it displays the older design.
- **NOTES** – column for information not noted by the other columns.

NOTE: If a service or option kit is installed on your machine, be sure to keep the KIT INSTRUCTIONS which came with the kit. It contains replacement parts numbers needed for ordering future parts.

NOTE: The number on the lower left corner of the front cover is the part number for this manual.

IMPORTANT SAFETY INSTRUCTIONS
When using an electrical appliance, basic precaution must always be followed, including the following:

READ ALL INSTRUCTIONS BEFORE USING THIS MACHINE.

 WARNING: To reduce the risk of fire, electric shock, or injury:

Use only indoors. Do not use outdoors or expose to rain.

Use only as described in this manual. Use only manufacturer's recommended components and attachments.

If the machine is **not working properly**, has been dropped, damaged, left outdoors, or dropped into water, return it to an authorized service center.

Do not operate the machine with any openings blocked. Keep openings free of debris that may reduce airflow.

Machine can cause a fire when operating near flammable vapors or materials. Do not operate this machine near flammable fluids, dust or vapors.

This machine is suitable for commercial use, for example in hotels, schools, hospitals, factories, shops and offices for more than normal housekeeping purposes.

Maintenance and repairs **must be done** by qualified personnel.

During operation, attention shall be paid to other persons, especially children.

The machine shall only be operated by instructed and authorized persons.

When leaving unattended, unplug the machine.

Do not handle the plug or machine with wet hands.

Do not unplug machine by pulling on cord. To unplug, grasp the plug, not the cord.

Do not use with damaged cord or plug. Follow all instructions in this manual concerning grounding the machine.

Do not pull or carry by cord, use cord as a handle, close a door on cord, or pull cord around sharp edges or corners.

Do not pull/run machine over cord. **Keep** cord away from heated surfaces.

Connect to a **properly** grounded outlet. See Grounding Instructions.

SAVE THESE INSTRUCTIONS

SAFETY

The following symbols are used throughout this guide as indicated in their descriptions:

HAZARD INTENSITY LEVEL

There are three levels of hazard intensity identified by signal words – **WARNING** and **CAUTION** and **FOR SAFETY**. The level of hazard intensity is determined by the following definitions:



WARNING – Hazards or unsafe practices which COULD result in severe personal injury or death.



CAUTION – Hazards or unsafe practices which could result in minor personal injury or product or property damage.

FOR SAFETY: To identify actions which must be followed for safe operation of equipment.

Report machine damage or faulty operation immediately. Do not use the machine if it is not in proper operating condition. Following is information that signals some potentially dangerous conditions to the operator or equipment. Read this information carefully. Know when these conditions can exist. Locate all safety devices on the devices on the machine. Please take the necessary steps to train the machine operating personnel.

FOR SAFETY:

DO NOT OPERATE MACHINE:

Unless Trained and Authorized.

Unless Operation Guide is Read and Understood.

In Flammable or Explosive areas.

In areas with possible falling objects.

WHEN SERVICING MACHINE:

Avoid moving parts. Do not wear loose fitting clothing, jackets, shirts, or sleeves when working on the machine. Use approved replacement parts.

GROUNDING INSTUCTIONS-120V

THIS PRODUCT IS FOR COMMERCIAL USE ONLY.

ELECTRICAL:

In the USA this machine operates on a one 15 amp nominal 120V, 60 hz, A.C. power circuit. The amp, hertz, and voltage are listed on the data label found on each machine. Using voltages above or below those indicated on the data label will cause serious damage to the motors.

GROUNDING INSTRUCTIONS:

This appliance must be grounded. If it should malfunction or break down, grounding provides a path of least resistance for electric current to reduce the risk of electric shock. This appliance is equipped with a cord having an equipment-grounding conductor and grounding plug. The plug must be inserted into an appropriate outlet that is properly installed and grounded in accordance with all local codes and ordinances.

This appliance is for use on a nominal 120-volt circuit, and has a grounded plug that looks like the plug in "Fig. A". A temporary adaptor that looks like the adaptor in "Fig . C" may be used to connect this plug to a 2-pole receptacle as shown in "Fig. B", if a properly grounded outlet is not available. The temporary adaptor should be used only until a properly grounded outlet (Fig. A) can be installed by a qualified electrician. The green colored rigid ear, lug, or the like extending from the adaptor must be connected to a permanent ground such as a properly grounded outlet box cover. Whenever the adaptor is used, it must be held in place by a metal screw.

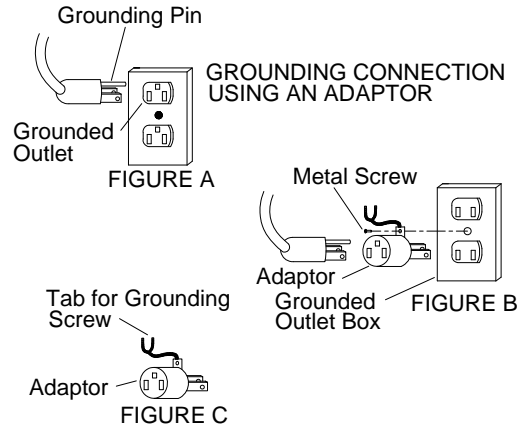

Note: Adaptors are not allowed in Canada.

! WARNING:

Improper connection of the equipment-grounding conductor can result in a risk of electric shock. Check with a qualified electrician or service person if you are in doubt as to whether the outlet is properly grounded. Do not modify the plug provided with the appliance - if it will not fit the outlet, have a proper outlet installed by a qualified electrician.

SAFETY

SAFETY LABEL LOCATION

NOTE: These drawings indicate the location of safety labels on the Machine. If, at any time, the labels become illegible contact your authorized representative for prompt replacement.

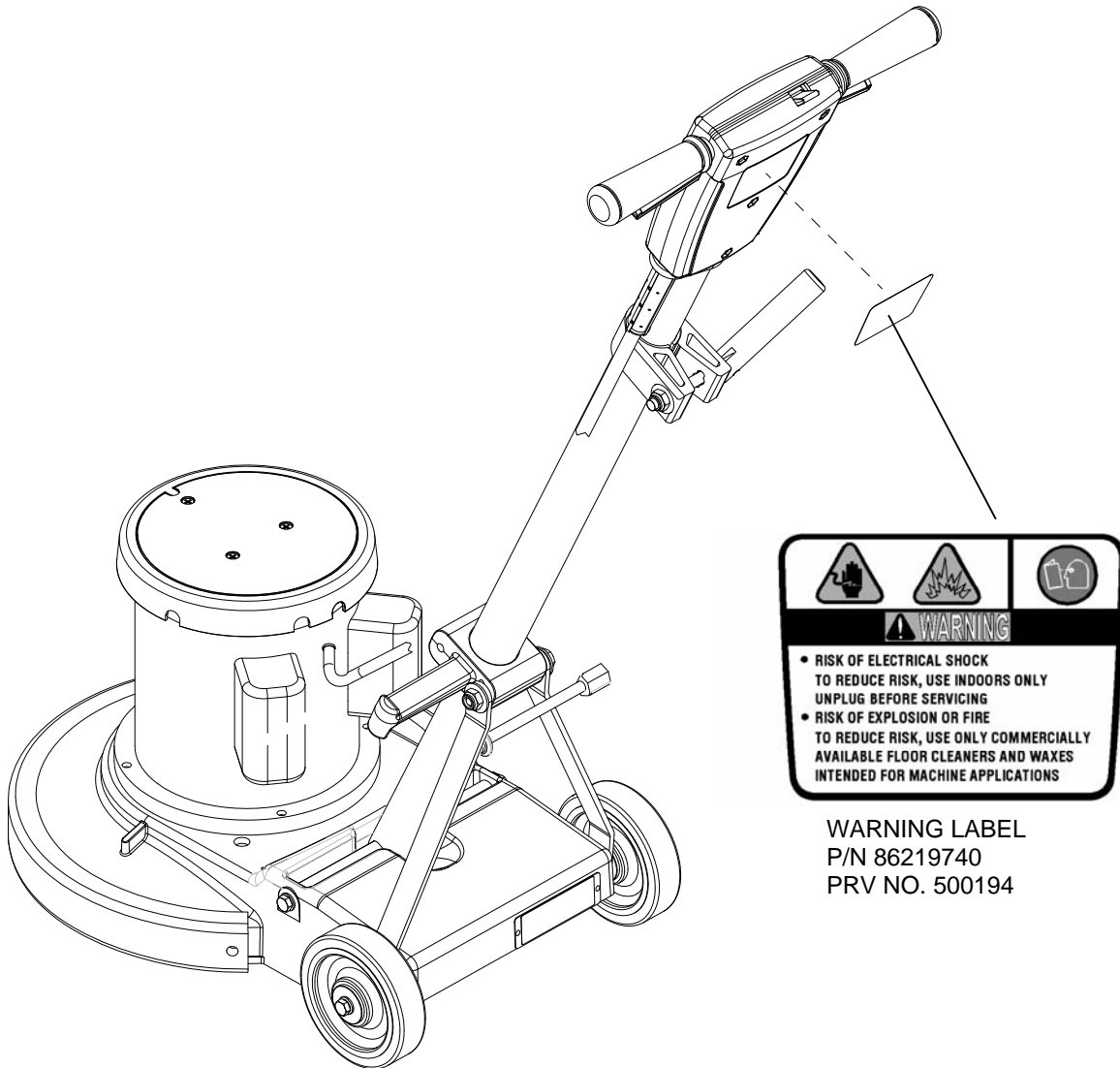

WARNING LABEL
P/N 86219740
PRV NO. 500194

NOTES:

TECHNICAL SPECIFICATIONS

ITEM	DIMENSION/CAPACITY/MODEL
CONSTRUCTION	Heavy-duty die cast aluminum deck with heavy-duty rubber bumper, tubular steel adjustable handle with die cast aluminum handle housing
MOTOR	
1.5HP 115V induction	BDS 43/175 C, BDS 51/175 C
1.75 HP 115V 175/300RPM	BDS 51/175-300C
BRUSH/PAD SPEED	
175 rpm	BDS 43/175 C, BDS 51/175 C
175/300 rpm	BDS 51/175-300C
ELECTRICAL SYSTEM	
115 volts, 60 Hz	
CABLE	
50' (15 m), 14/3, built in cord wrap	
SWITCHES	Dual levers with safety lock
WHEELS	Two 5" (12.7 cm) dia., 1.25" (3 cm) wide, non-marking tread
HANDLE	1.5" (4 cm) tubular steel, adjustable, easy to use thumb activated safety lock
DIMENSIONS (L X W X H)	
13" (33 cm) model	21.0" (53 cm) x 14" (36 cm) x 47" (119 cm)
15" (38 cm) model	22.0" (56 cm) x 16" (41 cm) x 47" (119 cm)
17" (43 cm) model	23.0" (58 cm) x 18" (46 cm) x 47" (119 cm)
20" (51 cm) model	24.5" (62 cm) x 21" (53 cm) x 47" (119 cm)

HANDLE INSTALLATION

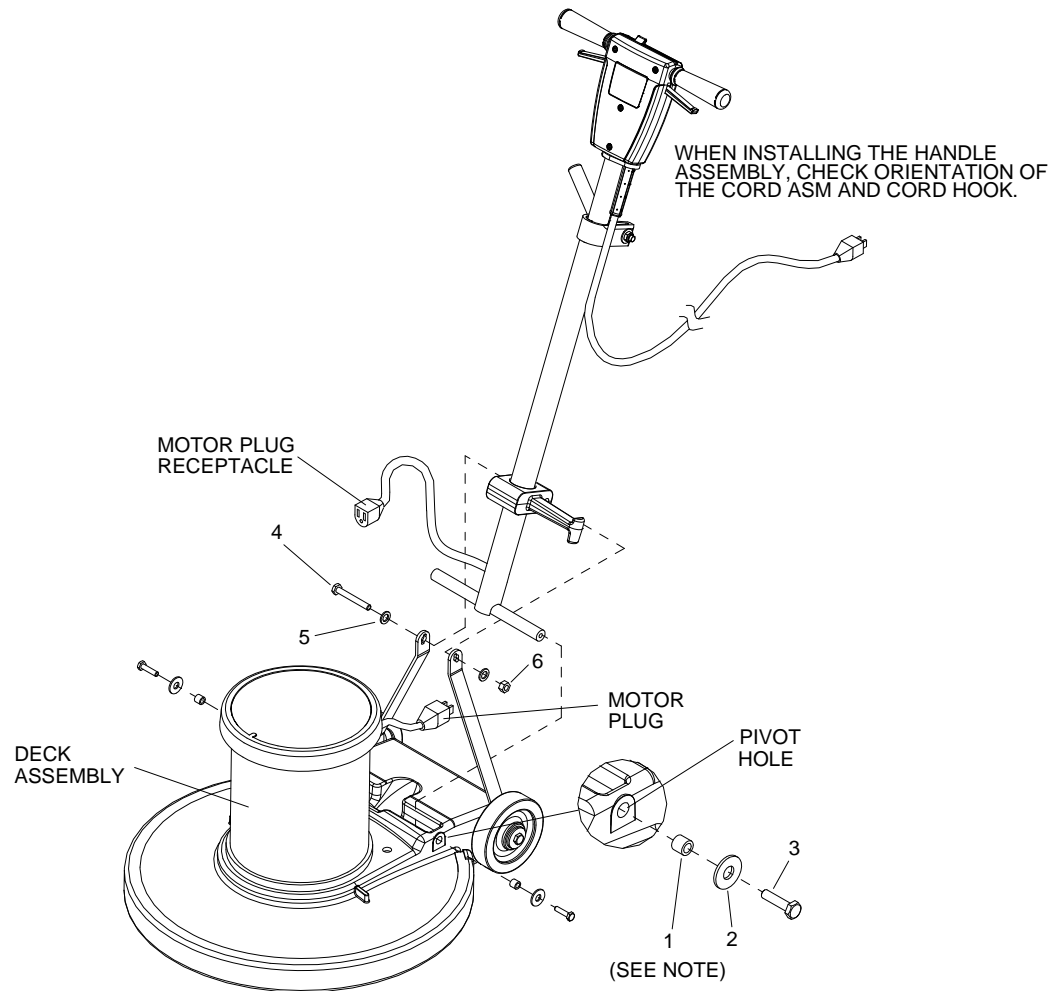

WARNING: The handle must be installed by qualified personnel. Read all instructions thoroughly. The machine is shipped with handle unassembled.

The machine is shipped with handle unassembled.

Follow these steps for installation:

1. Remove handle and deck assembly from carton.
2. Attach handle assembly to base using hardware kit (**86219680-PRV NO. 47331**) (attached to handle in a plastic bag) items 1, 2, and 3.

NOTE: The spacers (items 1) are required for the correct operation of the handle. The spacers are positioned completely inside the pivot holes in the casting, and are held in place by tightening the bolts and washers (items 2 and 3) against the spacer.

3. Remove bolt, nut and washers (items 4, 5 and 6) from lower block on handle assembly. Attach links as shown. Tighten bolt and nut securely, then back off 1/4 to 1/2 turn.
4. Check handle for movement up and down.
5. Plug motor cord into handle cord receptacle.

OPERATION

CONTROLS

1. **Safety Lock** – Prevents unintended operation of the machine.
2. **Switch Levers** – Turns machine on/off.
3. **Adjustment Handle** – Allows the handle to be adjusted to a comfortable operating position.

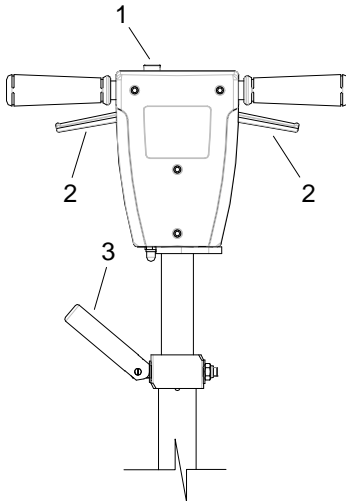

NOTE: It is incorrect to make it lock opposite from the way it was assembled by applying more force to the nut.

The pivot pin is off center in relationship to the axis of the handle. To adjust handle, tighten nut on handle while in the locked position. The handle is locked when the screw is to the outside of the machine and the flat on the opposite side of the handle is flush to the bracket.

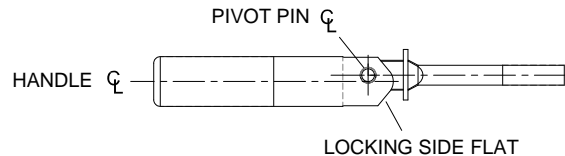

HANDLE HEIGHT ADJUSTMENT

NOTE: The handle is in the up, locked position from the factory.

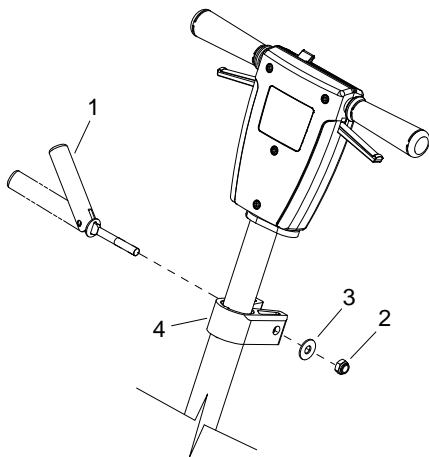

The handle adjust bar (1) for the polishers are individually preset at the factory for optimum locking efficiency and minimum effort of engaging. It should not be necessary to adjust the handle adjust bar unless the handle adjustment bar (1) the washer (3) and nut (2) have been disturbed.

MACHINE OPERATION

⚠ CAUTION:

For indoor use only.

⚠ CAUTION:

When using the pad, always keep the machine moving when in contact with the floor.

⚠ WARNING:

High starting torque. Hold machine firmly with both hands.

1. Ensure that the pad driver is in good shape. Install or change pad if necessary.
2. Plug the machine into a wall outlet as described in the grounding instructions.
3. Lower the handle by unlocking the adjustment handle and moving the handle into position. Relock the handle when it is in a comfortable position.

⚠ WARNING:

Insure that handle is locked in position before starting machine.

4. Push the safety lock forward, unlocking the switch levers.
5. With the safety lock forward, squeeze one or both of the switch levers, turning the machine on. (These levers can be operated independently of each other). The safety lock will not re-engage until both levers are released.
6. To stop the machine, release the switch levers.
7. Do not let machine rest on pad. When finished with the machine, return handle to the storage position.

NOTE: The machine is equipped with a circuit breaker to protect the motor in the event an overload condition occurs. The circuit breaker is located on the handle. Push the reset button to restart the machine. If the breaker trips again, correct the cause of overloading before proceeding.

DAILY MAINTENANCE

1. Inspect power cord for wear. To prevent electrical shock replace cords with frayed or cracked insulation immediately.
2. Place machine in the storage position.
3. Check pad condition. Change if soiled or torn.

PAD DRIVER/BRUSH INSTALLATION

1. Lay machine back, exposing the under side.
2. Place pad driver on the motor lug and rotate counter-clockwise until engaged. To remove, turn clockwise.

NOTES:

MAINTENANCE

SCRUB BRUSHES

NOTE: All original equipment brushes are equipped with "Perform Alert®". This feature will tell the operator when it is time to replace the scrub brushes. "Perform Alert®" brushes have pre-trimmed bright yellow tufts to indicate the length of a worn out brush. When the tufts in the scrub brush wear to a length equal to the yellow tufts, the scrub brushes should be replaced.

There are five different types of brushes available to cover applications from cleaning heavily soiled floors to polishing. A pad driver is also available to take advantage of the many cleaning pads on the market and further add to the flexibility of the machine.

Please refer to the following to assist in selecting the proper brush or pad for the work at hand.

UNCOATED FLOORS

Aggressive Grit is a nylon fiber impregnated with silicone carbide grit. It grinds away stain, soil, and removes surface material.

Mild Grit is a less aggressive silicone carbide grit suitable for cleaning medium soil conditions. Advantages are faster ground speed than nylon bristles on light solid applications.

Nylon is a general-purpose scrub brush with stiff bristles. Polypropylene works well for maintaining concrete, wood and tile floors.

FINISHED FLOORS

Nylon Polish is the softest brush. It will gently clean finished tile or terrazzo floors without removing floor finish or floor material. Used for washing highly polished or burnished floors.

Nylon bristles are used in a variety of applications on coated or uncoated surfaces.

White Pads (Polishing) are used for dry polishing to achieve a high-gloss appearance, or surface washing on highly polished or burnished floors.

Red Pads (Buffing) are used for light-duty scrubbing. When used with a mild detergent they will provide surface cleaning without removing the finish.

Blue Pads (Scrubbing) are used for heavy-duty scrubbing and light stripping. The blue pads remove less finish than brown stripping pads, yet will remove black marks, stains and dirt.

Brown Pads (Stripping) are used for easy and complete removal of old floor waxes/finishes. They will quickly remove ground in dirt, black heel marks, and spills. When used with the proper stripper, this pad leaves the floor clean and ready for finishing.

The scrub brushes should be checked before each days work for wire, string, wear and damage. The scrub brushes should be replaced if brush bristles are missing or if yellow Perform Alert ® indicates minimum brush length.

SERVICE SCHEDULE

MAINTENANCE	DAILY	MONTHLY
Check pad wear to prevent buildup of chemicals	*	
Check pad driver system for damage	*	
Check handles, switches, and knobs for damage	*	
Store with pad off the floor	*	
Check all bearings for noise		*
Check skirt/bumpers for damage and replace as necessary		*
Check overall performance of machine		*

MACHINE TROUBLESHOOTING

PROBLEM	CAUSE	SOLUTION
Machine will not run	Circuit breaker tripped in building.	Check and reset.
	Power switch failure	Test switch for continuity and replace if necessary.
	Tripped circuit breaker	Reset.
	Faulty power cord	Replace.
	Fuse in motor blown (Dual speed only)	Replace CAUTION: To reduce the risk of electrical shock, unplug the machine before opening fuse holder. Fuse will only open under extreme conditions. Investigate cause before replacing.
Electrical shock	Equipment not grounded	Follow grounding instructions exactly.
	Receptacle not grounded	Have an electrician inspect building's wiring.
	Internal wiring problem	Ensure that the machine wiring matches the appropriate wiring diagram. Replace any wires or components that are short circuiting.
Repeated circuit breaker tripping	Mechanical problem	Higher amp draws indicate a mechanical problem. Find the problem before using the machine.
	Faulty circuit breaker	Test circuit for continuity. Replace circuit breaker if necessary.
Excessive vibration	Pad not centered	Re-center pad.
	Damaged or unevenly worn pad	Replace pad. Do not rest machine on pad when not in use.
	Damaged pad driver	Replace.
Pad does not turn but motor is running	Sheer coupling has failed	Replace coupling.

NOTES:

BRUSH/PAD DRIVER

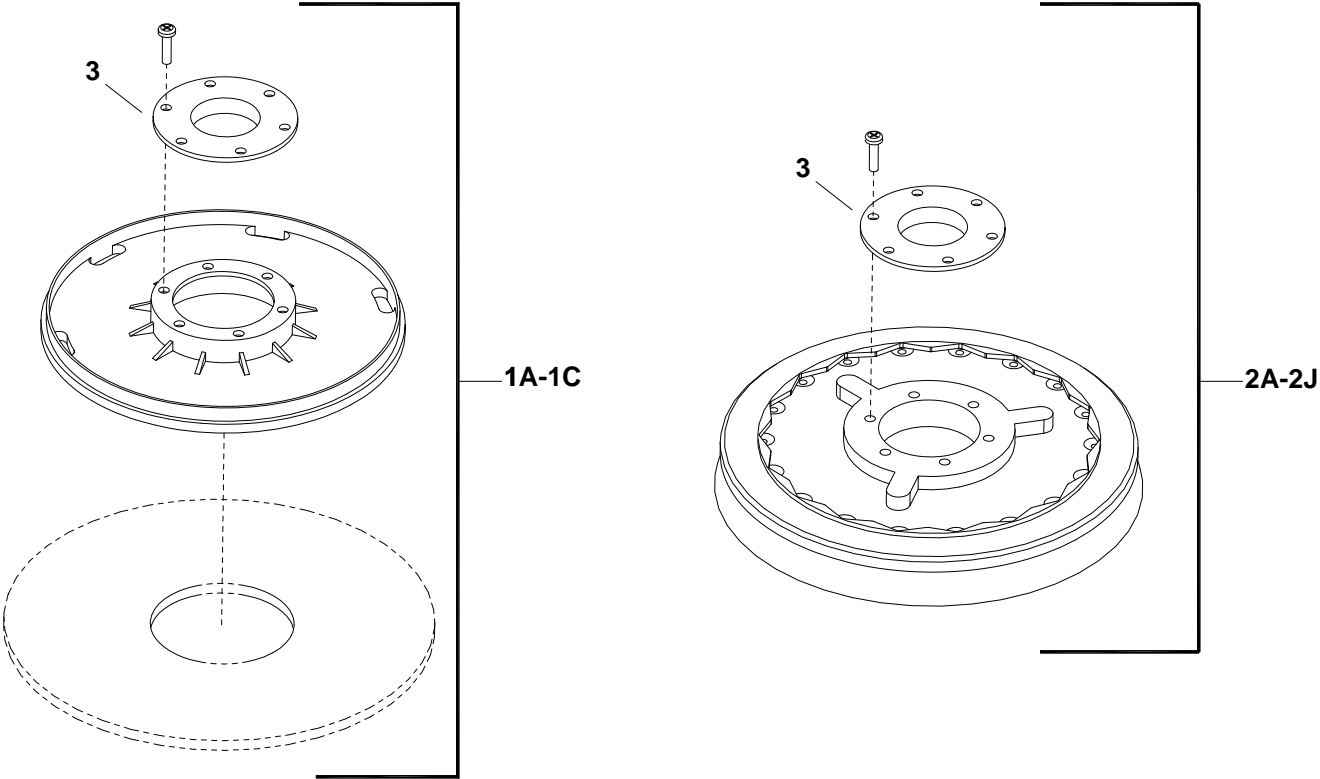

BRUSH/PAD DRIVER

REF	PART NO.	PRV NO.	QTY	DESCRIPTION	SERIAL NO. FROM	NOTES:
1A	86000120	02218	-	PAD DRIVER, 17" POLISHER		
1B	86284290	02217	-	PAD DRIVER, 19" HS		
1C	86284300	02219	-	PAD DRIVER, 20" POLISHER		
2A	86000140	02242	-	BRUSH, 17" NYL. POL. W/CLT.PLT		
2B	86283800	02240	-	BRUSH, 17" NYL.SCRUB W/CLT.PLT		
2C	86000130	02241	-	BRUSH, 17" MILD GRIT W/CLT.PLT		
2D	86283710	02205	-	BRUSH, 17" AGG. MALGRIT W/C.P		
2E	86000110	02206	-	BRUSH, 17" POLYPRO W/CLT. PLT		
2F	86283790	02239	-	BRUSH, 20" NYL.POL.W/CLT.PLT.SFT		
2G	86283770	02237	-	BRUSH, 20" NYL.SCRUB W/CLT.PLT		
2H	86283780	02238	-	BRUSH, 20" MILD GRIT W/CLT.PLT		
2I	86283690	02202	-	BRUSH, 20" AGG. MALGRIT W/C.P.		
2J	86283700	02203	-	BRUSH, 18" POLYPRO W/CLT. PLT		
3	86284350	02220	-	PLATE, PAD CLUTCH		

ELECTRICAL

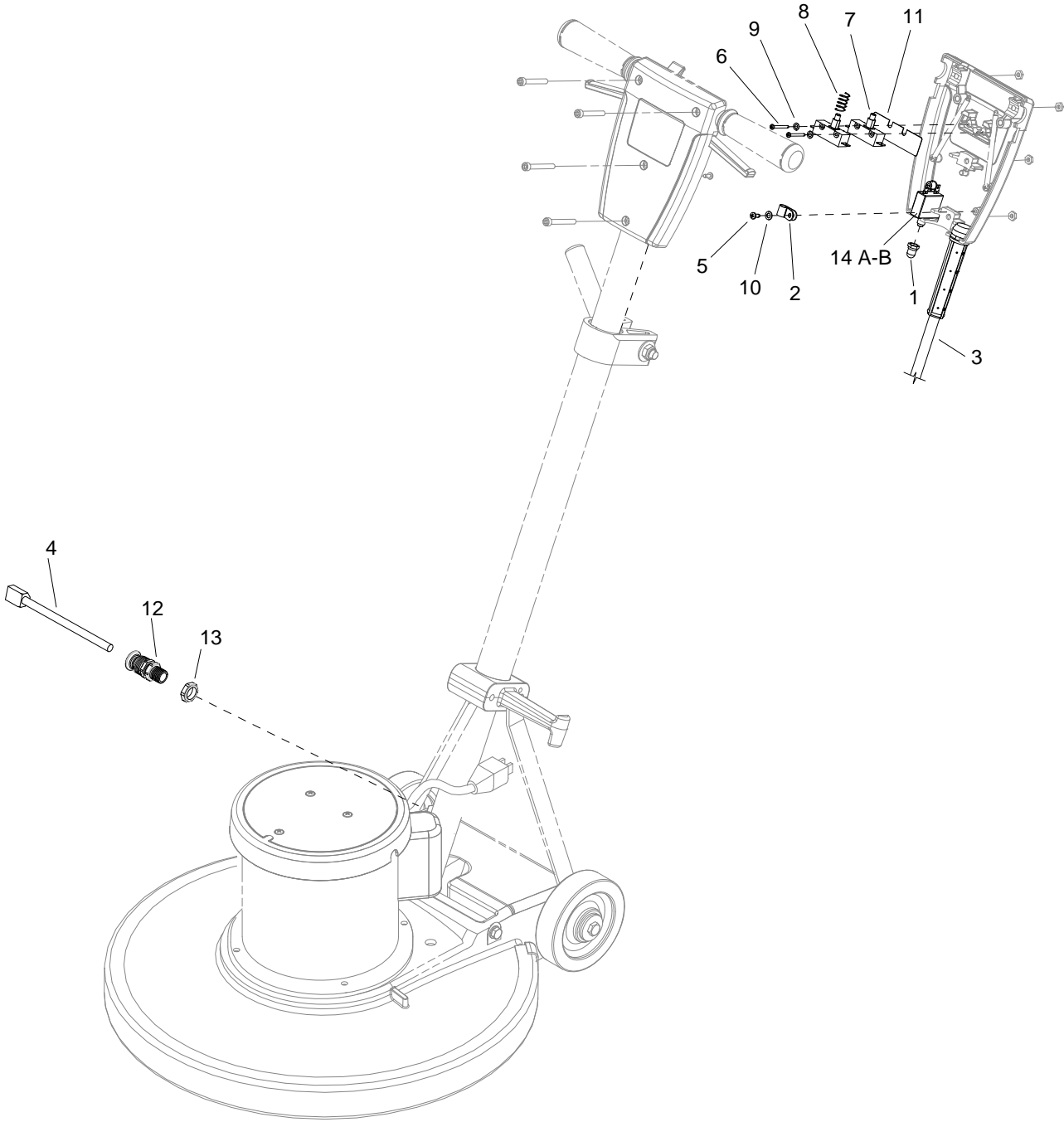

ELECTRICAL

REF	PART NO.	PRV NO.	QTY	DESCRIPTION	SERIAL NO. FROM	NOTES
1	86002010	14942	1	BOOT, 3/8 CIRCUIT BREAKER		
2	86198450	20005	1	CLAMP, 5/16 NYLON		
3	86234150	23167	1	CORD SET, 14/3 ST X 50FT, YLW		
4	86216920	23206	1	CORDSET, 14/3 X 52 IN, SJT, BLK		
5	86268450	70689	1	SCR, M4.8 X 10 HHTF TYPE B		
6	86136780	70801	2	SCR, M3.5 X 40 PHTF		
7	86007110	72123	2	SWITCH, 25A SPST 125-250V SNAP		
8	86224750	73993	1	SPRING, COMP, .48OD X .91		
9	86137290	87057	2	WASHER, M4 LOCK		
10	86137330	87208	1	WASHER, M5 LOCK		
11	86215140	140674	1	BARRIER SHEET		
12	86224930	730012	1	STRAIN RELIEF, 14/3 STRAIGHT		
13	86224300	730021	1	SPACER, POLISHER HANDLE		
14B	86312500	-	1	BREAKER, CIRCUIT, 13A VDE		BDS 43/175 C, BDS 51/175 C
14C	86312460	-	1	BREAKER, 14A, VDE CIRCUIT		BDS 51/175-300 C

DECK

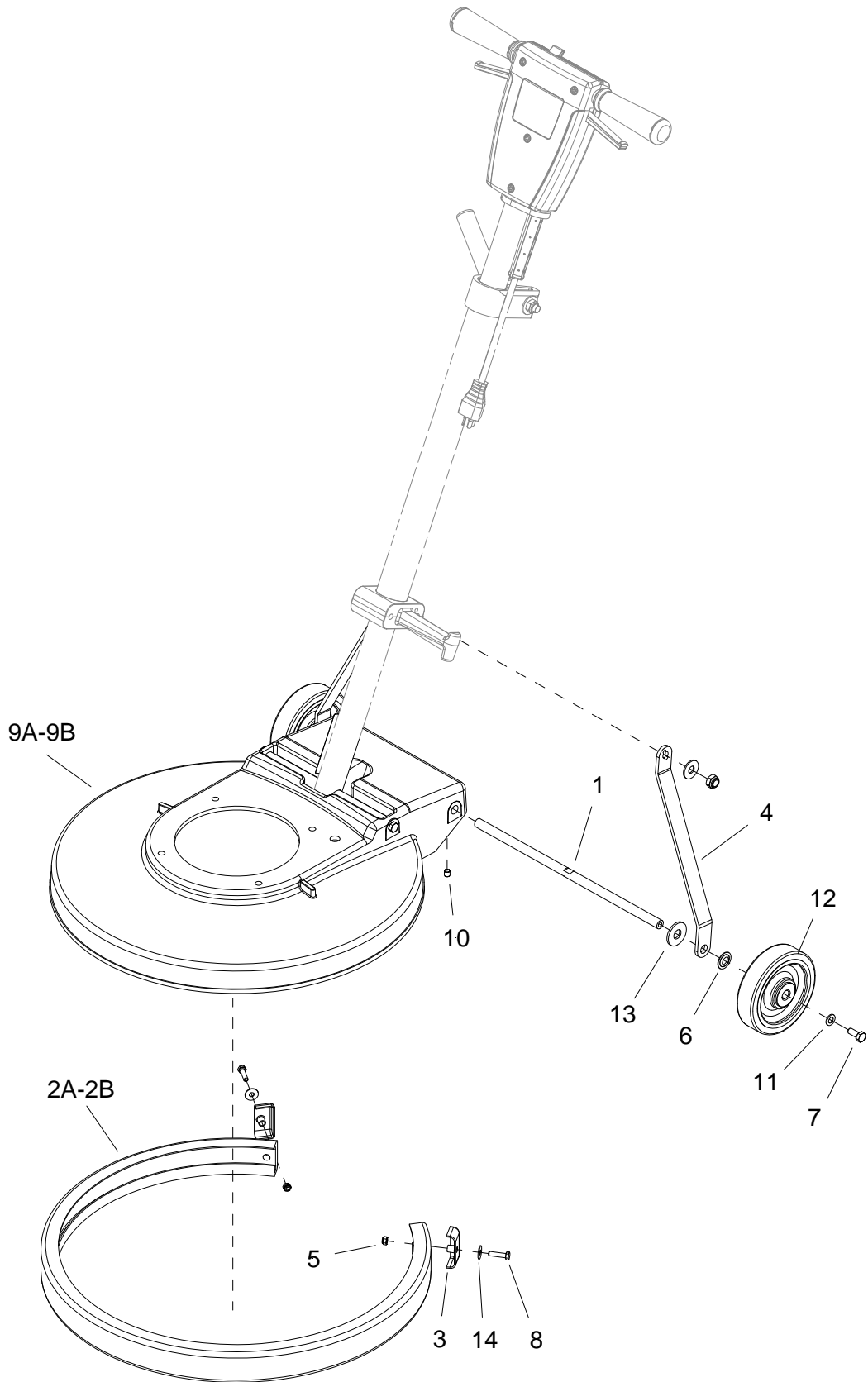

DECK

REF	PART NO.	PRV NO.	QTY	DESCRIPTION	SERIAL NO. FROM	NOTES
1	86214930	03111	1	AXLE, MAIN POLISHER		
2A	86216340	14372	-	BUMPER, EXTRUSION 41.0"		BDS 43/175 C
2B	86216350	14373	-	BUMPER, EXTRUSION 50.8"		BDS 51/175 C, BDS 51/175-300 C
3	86216600	27871	2	CAP, EXTRUSION		
4	86221860	51328	2	LINK, HANDLE ADJUST		
5	86271550	57220	2	NUT, M6 X 1 NYLOCK		
6	86222270	57276	2	NUT, PUSH FLAT RD .51 ID		
7	86133340	70262	2	SCR, M8-1.25 X 20 HHMS PLTD		
8	86276570	70691	2	SCR, M6 X 25 HHCS		
9A	86288960	29213GRY	1	DECK, 17 IN POLISHER, GRAY		BDS 43/175 C
9B	86288970	29214GRY	1	DECK, 20 IN POLISHER, GRAY		BDS 51/175 C, BDS 51/175-300 C
10	86288740	70709	1	SET SCR, 8MMX1.25X8MM CUP PT		
11	86137280	87054	2	WASHER, M8 FLAT DIN125A PLT		
12	86226020	89206	2	WHEEL, 5D X 1.25 X 13MMID GRY		
13	86225720	87203	2	WASHER, 14MMID X 36MMOD		
14	86137340	87211	2	WASHER, M6 FLAT BLK		

HANDLE

REF	PART NO.	PRV NO.	QTY	DESCRIPTION	SERIAL NO. FROM	NOTES
1	86215130	14344	1	BAR, HANDLE ADJUST		
2	86216370	14434	1	BUMPER, BURNISHER HANDLE		
3	86004070	36196	2	GRIP, POLISHER HANDLE		
4	86218440	38290	1	HANDLE, POLISHER		
5	86005150	51326	1	LOCK, SAFETY HANDLE		
6	86005160	51327	2	LEVER, SWITCH		
7	86136350	57274	4	NUT, M6 HEX FINISH		
8	86136360	57275	2	NUT, M10 X 1.5 HEX NYLOK PLTD		
9	86222560	66334	1	PIN, PIVOT, HANDLE ADJUST		
10	86223550	67430	1	ROD, HANDLE ADJUST		
11	86274230	70135	2	SCR, M8 X 30 HHMS		
12	86136670	70686	2	SCR, M6 X 45 SHCS, BLK		
13	86136680	70687	2	SCR, M6 X 50 SHCS, BLK		
14	86288450	70689	3	SCR, M4.8 X 10 HHTF TYPE B		
15	86136720	70701	1	SCR, M10 X 1.50 X 90 HHCS PLTD		
16	86224740	73990	2	SPRING, EXT, .50D X 3.5L		
17	86225370	78437	1	TUBE, GRIP HANDLE		
18	86137280	87054	2	WASHER, M8 FLAT DIN15A PLT		
19	86279080	87058	2	WASHER, M4 FLAT DIN125A PLT		
20	86010720	87086	3	WASHER, M10 X 30 PLTD		
21	86225710	87202	1	WASHER, BEARING (HANDLE ADJ)		
22	86137330	87208	1	WASHER, M5 LOCK SHAKEPROOF PLTD		
23	86224290	730008	2	SPACER, .317ID X .50D X .44LG		
24	86310950	-	1	CLAMP, HANDLE		
25	86311800	-	1	TUBE ASSY, HANDLE ADJ.		
26	86311810	-	1	HOUSING, POLSHR HANDLE RR, CB		
27	86311820	-	1	HOUSING, POLSHR HANDLE FRT,CB		

MOTOR

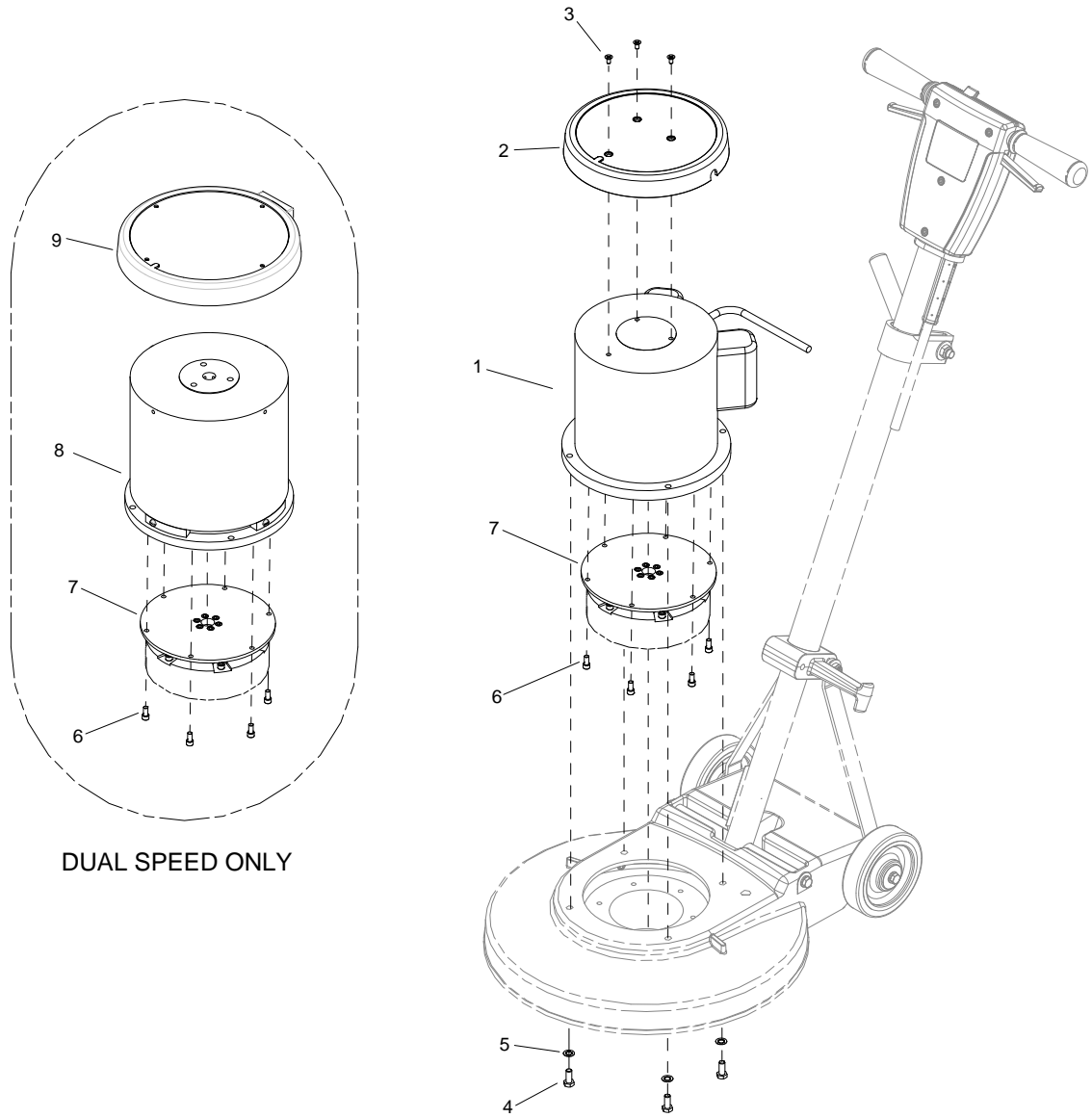

MOTOR

REF	PART NO.	PRV NO.	QTY	DESCRIPTION	SERIAL NO. FROM	NOTES
1	86312280	-	1	MOTOR, 1.5HP 115V INDUCTION		BDS 43/175 C, BDS 51/175 C
2	86217490	27884	1	COVER, MOTOR		BDS 43/175 C, BDS 51/175 C
3	86223690	70702	3	SCR, M5 X .8 X 15MM BLK		
4	86136710	70698	4	SCR, 5/16-18 X 3/4 HHCS GR5 BLK		
5	86279090	87067	4	WASHER, 5/16 LOCK INT STAR PLT		
6	86223700	70723	6	SCR, M5 X .8 X 15MM SHCS BLK		
7	86223030	62917	1	PLATE, ADAPTER POLISHER MOTOR		
8	86312290	-	1	MOTOR, 115V, 1.75HP 175/300RPM		BDS 51/175-300 C
9	86217500	27892	1	COVER ASM, MOTOR		BDS 51/175-300 C

WIRING-120V

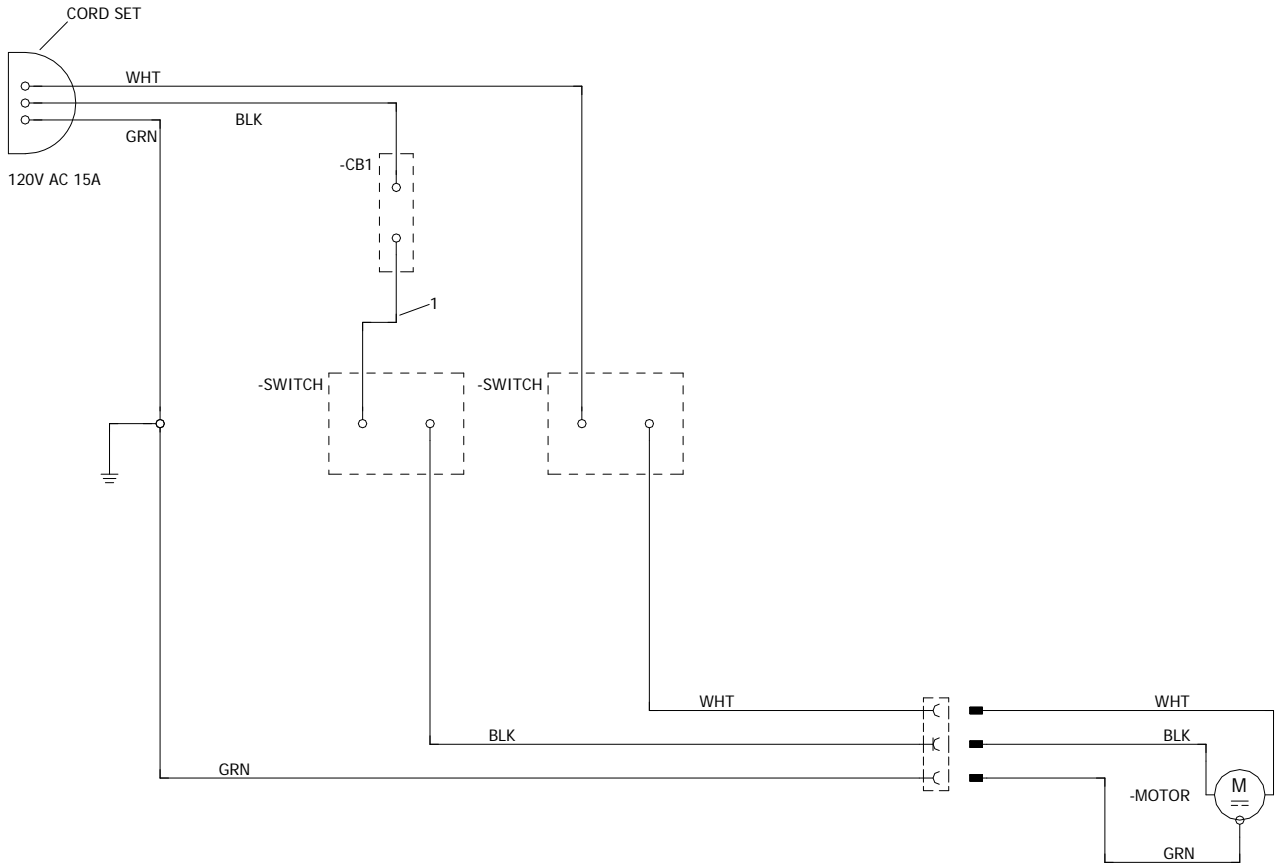

REF	PART NO.	PRV NO.	QTY	DESCRIPTION	SERIAL NO. FROM	NOTES:
1	86311830	-	1	WIRE, 125MM, BLK/14, 76029X76029		

SUGGESTED SPARE PARTS

PART NO.	PRV NO.		SERIAL NO. FROM	NOTES:
86225710	87202	WASHER, BEARING (HANDLE ADJ)		
86224740	73990	SPRING, EXT .5 OD X 3.5L		
86224750	73993	SPRING, COMP .48 OD X .91 L		
86007110	72123	SWITCH. 25A SPST 125-250V SNAP		
86215130	14344	BAR, HANDLE ADJ		
86222560	66334	PIN, PIVOT, HANDLE ADJ		
86223550	67430	ROD, HANDLE ADJ		
86003660	34378	FUSE		BDS 51/175-300 C
86003670	34379	FUSE HOLDER		BDS 51/175-300 C
86135540	27352	COUPLING, MTR/GEAR BOX PLSHER		BDS 51/175-300 C
86223390	67488	RECTIFIER, 50A 600V BRIDGE		BDS 51/175-300 C
86312500	-	BREAKER, CIRCUIT, 13A VDE		BDS 43/175 C, BDS 51/175 C
86312460	-	BREAKER, 14A, VDE CIRCUIT		BDS 51/175-300 C