

# FLOOR POLISHER

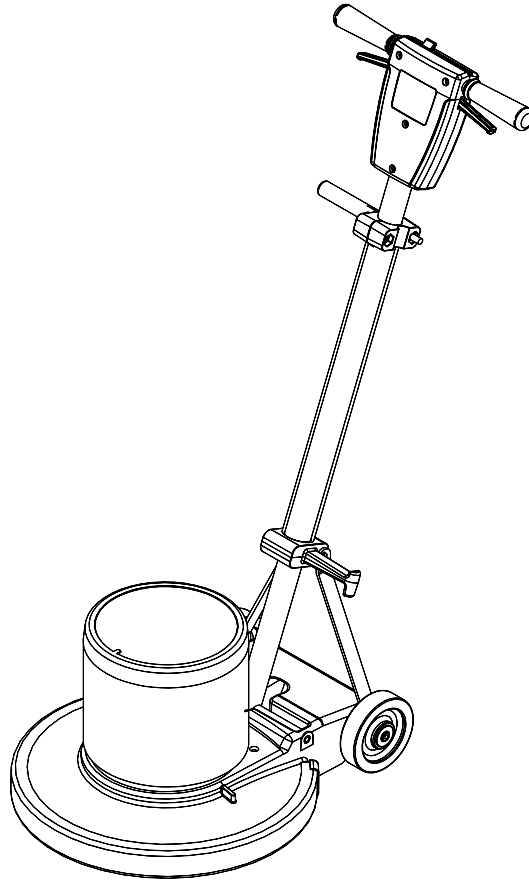

## MODELS:

U17-10090580	SP13-10090220	SPT17-10090370	BDS 43/175 C-10090710
U20-10090600	SP15-10090230	SPT20X-10090380	BDS 51/175 C-10090720
U17X-10090590	SP17-10090240		BDS 51/175-300 C-10090700
U20X-10090610	SP20-10090310		
UDS20-10090630	SP17X-10090280		
	SP20X-10090320		
	SPDS20-10090350		



Operating Instructions (ENG)



 **CLICK TO ORDER PARTS**

## **MACHINE DATA LOG/OVERVIEW**

Model: \_\_\_\_\_

Date of Purchase: \_\_\_\_\_

Serial Number: \_\_\_\_\_

Sales Representative: \_\_\_\_\_

Address: \_\_\_\_\_

Phone Number: \_\_\_\_\_

# TABLE OF CONTENTS

<i>Machine Data Log/Overview.....</i>	<i>2</i>
<i>Table of Contents.....</i>	<i>3</i>

## HOW TO USE THIS MANUAL

<i>How to use this Manual.....</i>	<i>1-1</i>
------------------------------------	------------

## SAFETY

<i>Important Safety Instructions .....</i>	<i>2-1</i>
<i>Hazard Intensity Level. ....</i>	<i>2-2</i>
<i>Grounding Instructions.....</i>	<i>2-3</i>

## OPERATION

<i>Technical Specifications .....</i>	<i>3-1</i>
<i>Handle Installation .....</i>	<i>3-2</i>
<i>Operation .....</i>	<i>3-3</i>
<i>Pad Driver Installation.....</i>	<i>3-4</i>

## MAINTENANCE

<i>Maintenance .....</i>	<i>4-1</i>
<i>Machine Troubleshooting.....</i>	<i>4-2</i>
<i>Wiring Diagram. ....</i>	<i>4-3</i>

## GROUP PARTS LIST

<i>Brush/Pad Driver Group.....</i>	<i>5-1</i>
<i>Frame Group.....</i>	<i>5-3</i>
<i>Motor Group.....</i>	<i>5-5</i>
<i>Handle Group.....</i>	<i>5-7</i>
<i>Wiring Group.....</i>	<i>5-9</i>
<i>Suggested Spare Parts.....</i>	<i>5-11</i>
<i>Warranty .....</i>	<i>5-12</i>

# HOW TO USE THIS MANUAL

This manual contains the following sections:

- HOW TO USE THIS MANUAL
- SAFETY
- OPERATIONS
- MAINTENANCE
- PARTS LIST

The HOW TO USE THIS MANUAL section will tell you how to find important information for ordering correct repair parts.

Parts may be ordered from authorized dealers. When placing an order for parts, the machine model and machine serial number are important. Refer to the MACHINE DATA box which is filled out during the installation of your machine. The MACHINE DATA box is located on the inside of the front cover of this manual.

MODEL _____
DATE OF PURCHASE _____
SERIAL NUMBER _____
SALES REPRESENTATIVE # _____

The model and serial number of your machine are located below the battery compartment of the machine.

The SAFETY section contains important information regarding hazard or unsafe practices of the machine. Levels of hazards are identified that could result in product or personal injury, or severe injury resulting in death.

The OPERATIONS section is to familiarize the operator with the operation and function of the machine.

The MAINTENANCE section contains preventive maintenance to keep the machine and its components in good working condition. They are listed in this general order:

The PARTS LIST section contains assembled parts illustrations and corresponding parts list. The parts lists include a number of columns of information:

- **REF** – column refers to the reference number on the parts illustration.
- **PART NO.** – column lists the part number for the part.
- **PRV NO.** - reference number.
- **QTY** – column lists the quantity of the part used in that area of the machine.
- **DESCRIPTION** – column is a brief description of the part.
- **SERIAL NO. FROM** – column indicates the first machine the part number is applicable to. When the machine design has changed, this column will indicate serial number of applicable machine. The main illustration shows the most current design of the machine. The boxed illustrations show older designs. If column has an asterisk (\*), call manufacturer for serial number.
- **NOTES** – column for information not noted by the other columns.

**NOTE:** If a service or option kit is installed on your machine, be sure to keep the KIT INSTRUCTIONS which came with the kit. It contains replacement parts numbers needed for ordering future parts.

**NOTE:** The number on the lower left corner of the front cover is the part number for this manual.

# IMPORTANT SAFETY INSTRUCTIONS

When using an electrical appliance, basic precaution must always be followed, including the following:

READ ALL INSTRUCTIONS BEFORE USING THIS MACHINE.



To reduce the risk of fire, electric shock, or injury:

**Use only** indoors. Do not use outdoors or expose to rain.

**Use only** as described in this manual. Use only manufacturer's recommended components and attachments.

If the machine is **not working properly**, has been dropped, damaged, left outdoors, or dropped into water, return it to an authorized service center.

**Do not** operate the machine with any openings blocked. Keep openings free of debris that may reduce airflow.

**Machine can cause a fire** when operating near flammable vapors or materials. Do not operate this machine near flammable fluids, dust or vapors.

**This machine is suitable for commercial use, for example in hotels, schools, hospitals, factories, shops and offices for more than normal housekeeping purposes.**

Maintenance and repairs **must be done** by qualified personnel.

**During operation**, attention shall be paid to other persons, especially children.

**The machine shall only** be operated by instructed and authorized persons.

**When leaving unattended**, unplug the machine.

**Do not** handle the plug or machine with wet hands.

**Do not** unplug machine by pulling on cord. To unplug, grasp the plug, not the cord.

**Do not** use with damaged cord or plug. Follow all instructions in this manual concerning grounding the machine.

**Do not** pull or carry by cord, use cord as a handle, close a door on cord, or pull cord around sharp edges or corners.

**Do not** pull/run machine over cord. **Keep** cord away from heated surfaces.

Connect to a **properly** grounded outlet. See Grounding Instructions.

## SAVE THESE INSTRUCTIONS

## **HAZARD INTENSITY LEVEL**

The following symbols are used throughout this guide as indicated in their descriptions:

### **HAZARD INTENSITY LEVEL**

There are three levels of hazard intensity identified by signal words – **WARNING** and **CAUTION** and **FOR SAFETY**. The level of hazard intensity is determined by the following definitions:

#### **⚠ WARNING:**

**WARNING** – Hazards or unsafe practices which COULD result in severe personal injury or death.

#### **⚠ CAUTION:**

**CAUTION** – Hazards or unsafe practices which could result in minor personal injury or product or property damage.

#### ***FOR SAFETY: To identify actions which must be followed for safe operation of equipment.***

Report machine damage or faulty operation immediately. Do not use the machine if it is not in proper operating condition. Following is information that signals some potentially dangerous conditions to the operator or equipment. Read this information carefully. Know when these conditions can exist. Locate all safety devices on the devices on the machine. Please take the necessary steps to train the machine operating personnel.

#### ***FOR SAFETY:***

**DO NOT OPERATE MACHINE:**

Unless Trained and Authorized.

Unless Operation Guide is Read and Understood.

In Flammable or Explosive areas.

In areas with possible falling objects.

#### ***WHEN SERVICING MACHINE:***

**Avoid moving parts. Do not wear loose fitting clothing, jackets, shirts, or sleeves when working on the machine. Use approved replacement parts.**

## GROUNDING INSTRUCTIONS

**THIS PRODUCT IS FOR COMMERCIAL USE ONLY.**

### ELECTRICAL:

In the USA this machine operates on a one 15 amp nominal 120V, 60 hz, A.C. power circuit. The amp, hertz, and voltage are listed on the data label found on each machine. Using voltages above or below those indicated on the data label will cause serious damage to the motors.

### GROUNDING INSTRUCTIONS:

This appliance must be grounded. If it should malfunction or break down, grounding provides a path of least resistance for electric current to reduce the risk of electric shock. This appliance is equipped with a cord having an equipment-grounding conductor and grounding plug. The plug must be inserted into an appropriate outlet that is properly installed and grounded in accordance with all local codes and ordinances.

This appliance is for use on a nominal 120-volt circuit, and has a grounded plug that looks like the plug in "Fig. A". A temporary adaptor that looks like the adaptor in "Fig. C" may be used to connect this plug to a 2-pole receptacle as shown in "Fig. B", if a properly grounded outlet is not available. The temporary adaptor should be used only until a properly grounded outlet (Fig. A) can be installed by a qualified electrician. The green colored rigid ear, lug, or the like extending from the adaptor must be connected to a permanent ground such as a properly grounded outlet box cover. Whenever the adaptor is used, it must be held in place by a metal screw.

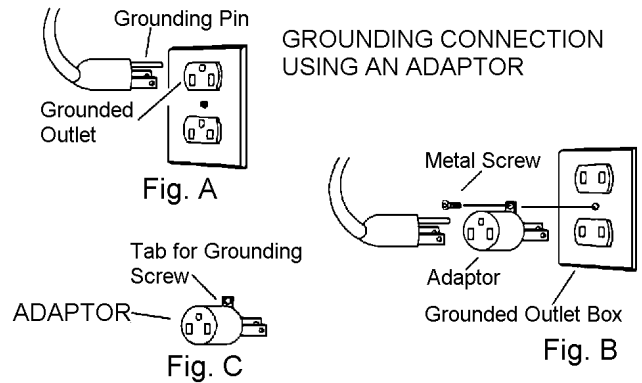

Note: Adaptors are not allowed in Canada.

## **⚠ WARNING:**

**Improper connection of the equipment-grounding conductor can result in a risk of electric shock. Check with a qualified electrician or service person if you are in doubt as to whether the outlet is properly grounded. Do not modify the plug provided with the appliance - if it will not fit the outlet, have a proper outlet installed by a qualified electrician.**

## TECHNICAL SPECIFICATIONS

ITEM	DIMENSION/CAPACITY
Construction	Heavy-duty die cast aluminum deck with heavy-duty rubber bumper, tubular steel adjustable handle with die cast aluminum handle housing
<b>Motor</b>	
U17, U20, 13, SP15, SP17, SP20, SPT17	1.0 hp
U17X, U20X, SP17X, SP20X, SPDS20, SPT20X	1.5 hp
<b>Brush/Pad speed</b>	
U17, U20, U17X, U20X, SP13, SP15, SP17, SP20, SP17X, SP20X, SPT17, SPT20X	175 rpm
UDS20, SPDS20	175/300 rpm
Electrical system	115 volts, 60 Hz
Cable	50' (15 m), 14/3, built in cord wrap
Switches	Dual levers with safety lock
Wheels	Two 5" (12.7 cm) dia., 1.25" (3 cm) wide, non-marking tread
Handle	1.5" (4 cm) tubular steel, adjustable, easy to use thumb activated safety lock
<b>Dimensions (L x W x H)</b>	
13" (33 cm) model	21.0" (53 cm) x 14" (36 cm) x 47" (119 cm)
15" (38 cm) model	22.0" (56 cm) x 16" (41 cm) x 47" (119 cm)
17" (43 cm) model	23.0" (58 cm) x 18" (46 cm) x 47" (119 cm)
20" (51 cm) model	24.5" (62 cm) x 21" (53 cm) x 47" (119 cm)

## HANDLE INSTALLATION

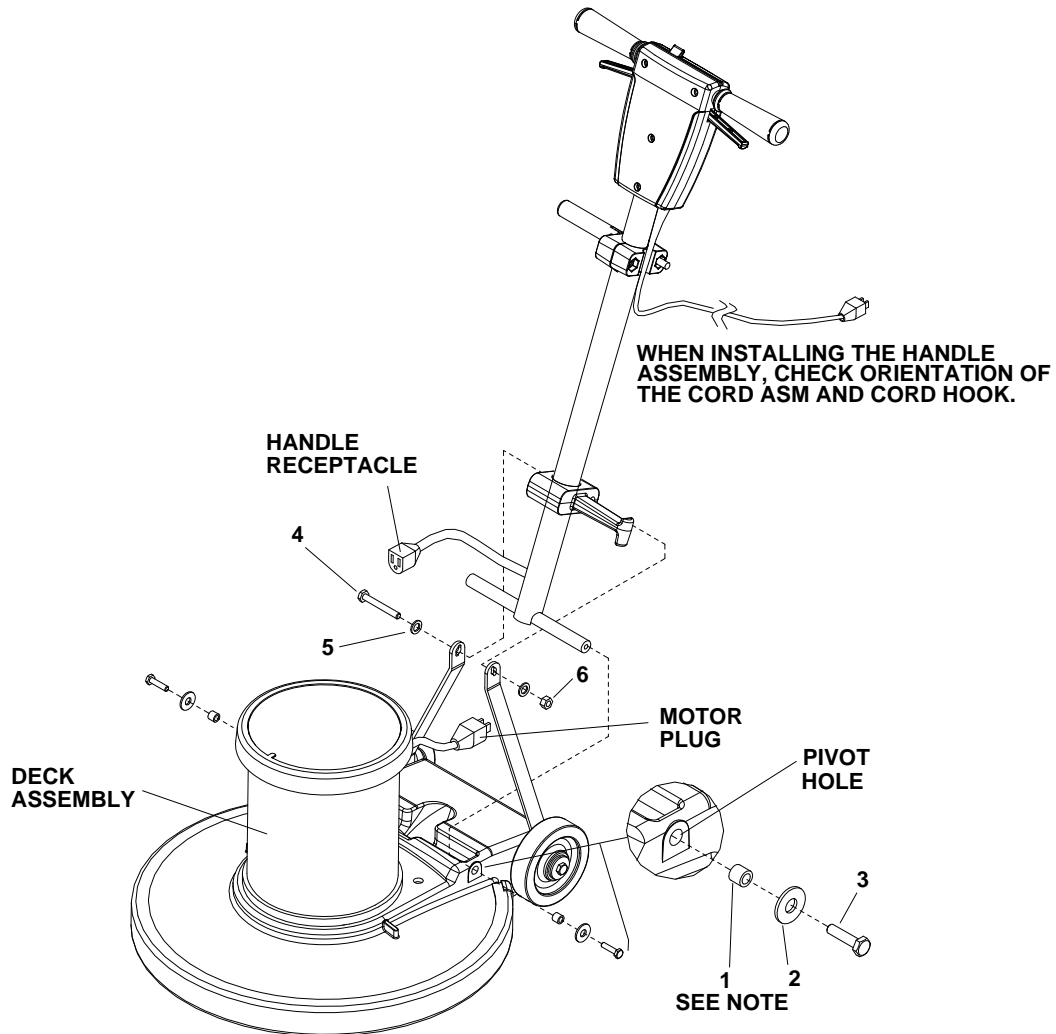

### **⚠ WARNING:**

***This must be installed by qualified personnel. Read all instructions thoroughly. The machine is shipped with handle unassembled.***

The machine is shipped with handle unassembled.

Follow these steps for installation:

1. Remove handle (**86218450-PRV NO. 38291**) and deck assembly from carton.
2. Attach handle assembly to base using hardware kit (**86219680-PRV NO. 47331**) (attached to handle in a plastic bag) items 1, 2, and 3.

**NOTE:** The spacers (items 1) are required for the correct operation of the handle. The spacers are positioned completely inside the pivot holes in the casting, and are held in place by tightening the bolts and washers (items 2 and 3) against the spacer.

3. Remove bolt, nut and washers (items 4, 5 and 6) from lower block on handle assembly. Attach links as shown. Tighten bolt and nut securely, then back off 1/4 to 1/2 turn.
4. Check handle for movement up and down.
5. Plug motor cord into handle cord receptacle.

# OPERATION

## CONTROLS

1. **Safety Lock** – Prevents unintended operation of the machine.
2. **Switch Levers** – Turns machine on/off.
3. **Adjustment Handle** – Allows the handle to be adjusted to a comfortable operating position.

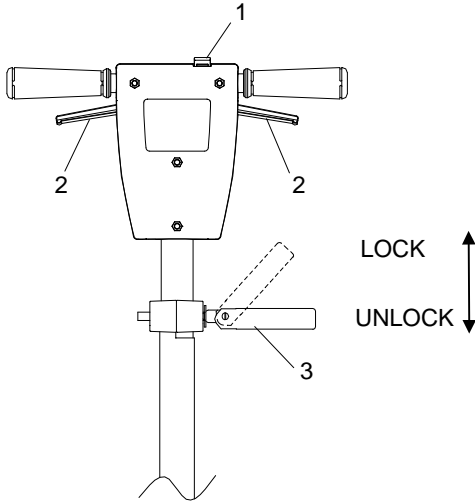

The handle adjust bar (86215130-PRV NO. 14344) for the polishers are individually preset at the factory for optimum locking efficiency and minimum effort of engaging. It should not be necessary to adjust the handle adjust bar unless the relationship of the handle adjust bar nut (86136360-PRV NO.57275) or fixed clamp bolt (86136700-PRV NO.70692) and their corresponding nuts (86136360-PRV NO. 57275) and washer (86010720-PRV NO.87086) have been disturbed. The handle can be positioned to be locked with the handle adjust bar pointing either up or down. In order to change the position the handle and bolt must be removed and rotated 180 degrees. It is incorrect to make it lock opposite from the way it was assembled by applying more force to the nut. From the factory the locking is in the up position when the machine handle is locked. The pivot pin (86222560-PRV NO. 66334) on the handle adjust bar is off center, in relationship of the screw to the axis of the (see drawing). To adjust handle adjust bar, tighten nut on handle while in the locked position. The handle is locked when the screw is to the outside of the machine and the flat on the opposite side of the handle is flush to the bracket.

1. To adjust handle lock, tighten nut on handle while in the locked position. Optimum locking force and ease of locking is accomplished when the locking lever nut is set to a torque of 30 to 50 inch pounds in the locked position.
2. Gap between clamp halves at the front should be to the gap in rear when the handle adjust bar is adjusted properly and in the locked position (gap approximately 1/16").

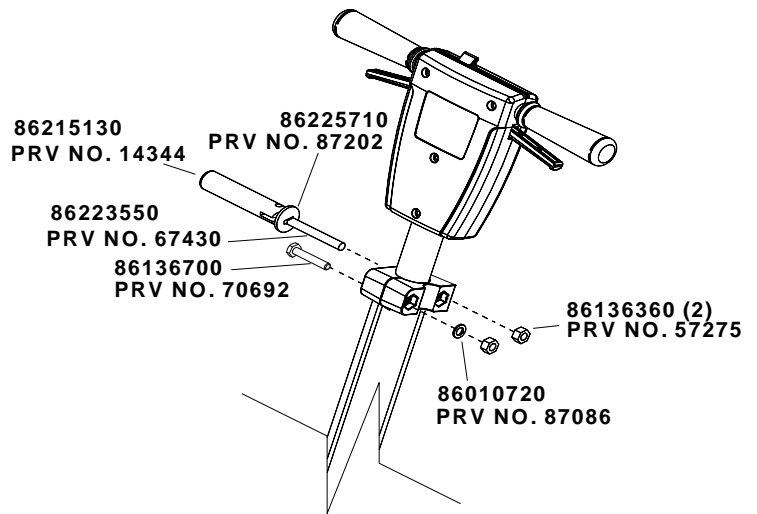

**SHOWN HANDLE IS IN LOCK POSITION**

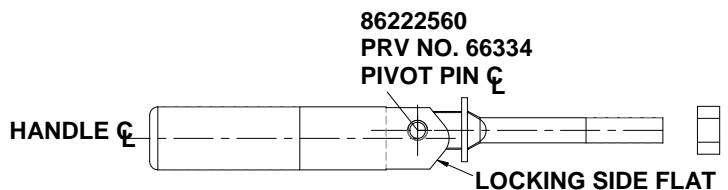
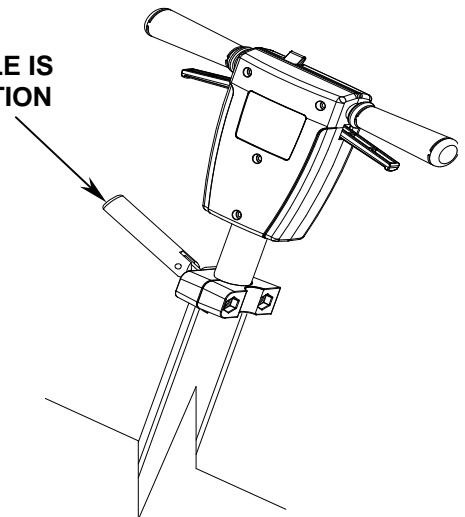

## OPERATION

### **⚠ CAUTION**

For indoor use only.

When using the pad, always keep the machine moving when in contact with the floor.

### **⚠ WARNING**

High starting torque. Hold machine firmly with both hands.

1. Ensure that the pad driver is in good shape. Install or change pad if necessary.
2. Plug the machine into a wall outlet as described in the grounding instructions.
3. Lower the handle by unlocking the adjustment handle and moving the handle into position. Relock the handle when it is in a comfortable position.

### **⚠ WARNING**

Insure that handle is locked in position before starting machine.

4. Push the safety lock forward, unlocking the switch levers.
5. With the safety lock forward, squeeze one or both of the switch levers, turning the machine on. (These levers can be operated independently of each other). The safety lock will not re-engage until both levers are released.
6. To stop the machine, release the switch levers.
7. Do not let machine rest on pad. When finished with the machine, return handle to the storage position.

*NOTE: The machine is equipped with a circuit breaker to protect the motor in the event an overload condition occurs. The circuit breaker is located on the rear of the motor. Push the reset button to restart the machine. If the breaker trips again, correct the cause of overloading before proceeding.*

## DAILY MAINTENANCE

1. Inspect power cord for wear. To prevent electrical shock replace cords with frayed or cracked insulation immediately.
2. Place machine in the storage position.
3. Check pad condition. Change if soiled or torn.

## PAD INSTALLATION

1. Lay machine back, exposing the under side.

Ensure pad is centered on pad driver. Pull pad to edge of pad driver in several directions to check for proper engagement.

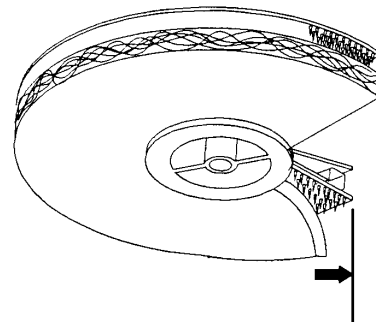

*NOTE: Use care when replacing center lock to prevent cross threading.*

**Notes:**

## SCRUB BRUSHES

*NOTE: All original equipment brushes are equipped with "Perform Alert®". This feature will tell the operator when it is time to replace the scrub brushes. "Perform Alert®" brushes have pre-trimmed bright yellow tufts to indicate the length of a worn out brush. When the tufts in the scrub brush wear to a length equal to the yellow tufts, the scrub brushes should be replaced.*

There are five different types of brushes available to cover applications from cleaning heavily soiled floors to polishing. A pad driver is also available to take advantage of the many cleaning pads on the market and further add to the flexibility of the Decathlon.

Please refer to the following to assist in selecting the proper brush or pad for the work at hand.

## UNCOATED FLOORS

**Aggressive Grit** is a nylon fiber impregnated with silicone carbide grit. It grinds away stain, soil, and removes surface material.

**Mild Grit** is a less aggressive silicone carbide grit suitable for cleaning medium soil conditions. Advantages are faster ground speed than nylon bristles on light solid applications.

**Nylon** is a general-purpose scrub brush with stiff bristles. Polypropylene works well for maintaining concrete, wood and tile floors.

## FINISHED FLOORS

**Nylon Polish** is the softest brush. It will gently clean finished tile or terrazzo floors without removing floor finish or floor material. Used for washing highly polished or burnished floors.

**Nylon** bristles are used in a variety of applications on coated or uncoated surfaces.

**White Pads** (Polishing) are used for dry polishing to achieve a high-gloss appearance, or surface washing on highly polished or burnished floors.

**Red Pads** (Buffing) are used for light-duty scrubbing. When used with a mild detergent they will provide surface cleaning without removing the finish.

**Blue Pads** (Scrubbing) are used for heavy-duty scrubbing and light stripping. The blue pads remove less finish than brown stripping pads, yet will remove black marks, stains and dirt.

**Brown Pads** (Stripping) are used for easy and complete removal of old floor waxes/finishes. They will quickly remove ground in dirt, black heel marks, and spills. When used with the proper stripper, this pad leaves the floor clean and ready for finishing.

The scrub brushes should be checked before each days work for wire, string, wear and damage. The scrub brushes should be replaced if brush bristles are missing or if yellow Perform Alert © indicates minimum brush length.

## MACHINE TROUBLESHOOTING

PROBLEM	CAUSE	SOLUTION
Machine will not run	Circuit breaker tripped in building.	Check and reset.
	Power switch failure	Test switch for continuity and replace if necessary.
	Tripped circuit breaker	Reset.
	Faulty power cord	Replace.
	Fuse in motor blown	Replace CAUTION: To reduce the risk of electrical shock, unplug the machine before opening fuse holder. Fuse will only open under extreme conditions. Investigate cause before replacing.
Electrical shock	Equipment not grounded	Follow grounding instructions exactly.
	Receptacle not grounded	Have an electrician inspect building's wiring.
	Internal wiring problem	Ensure that the machine wiring matches the appropriate wiring diagram. Replace any wires or components that are short circuiting.
Repeated circuit breaker tripping	Mechanical problem	Higher amp draws indicate a mechanical problem. Find the problem before using the machine.
	Faulty circuit breaker	Test circuit for continuity. Replace circuit breaker if necessary.
Excessive vibration	Pad not centered	Re-center pad.
	Damaged or unevenly worn pad	Replace pad. Do not rest machine on pad when not in use.
	Damaged pad driver	Replace.
Pad does not turn but motor is running	Sheer coupling has failed	Replace coupling.

**NOTES:**

# BRUSH/PAD DRIVER GROUP

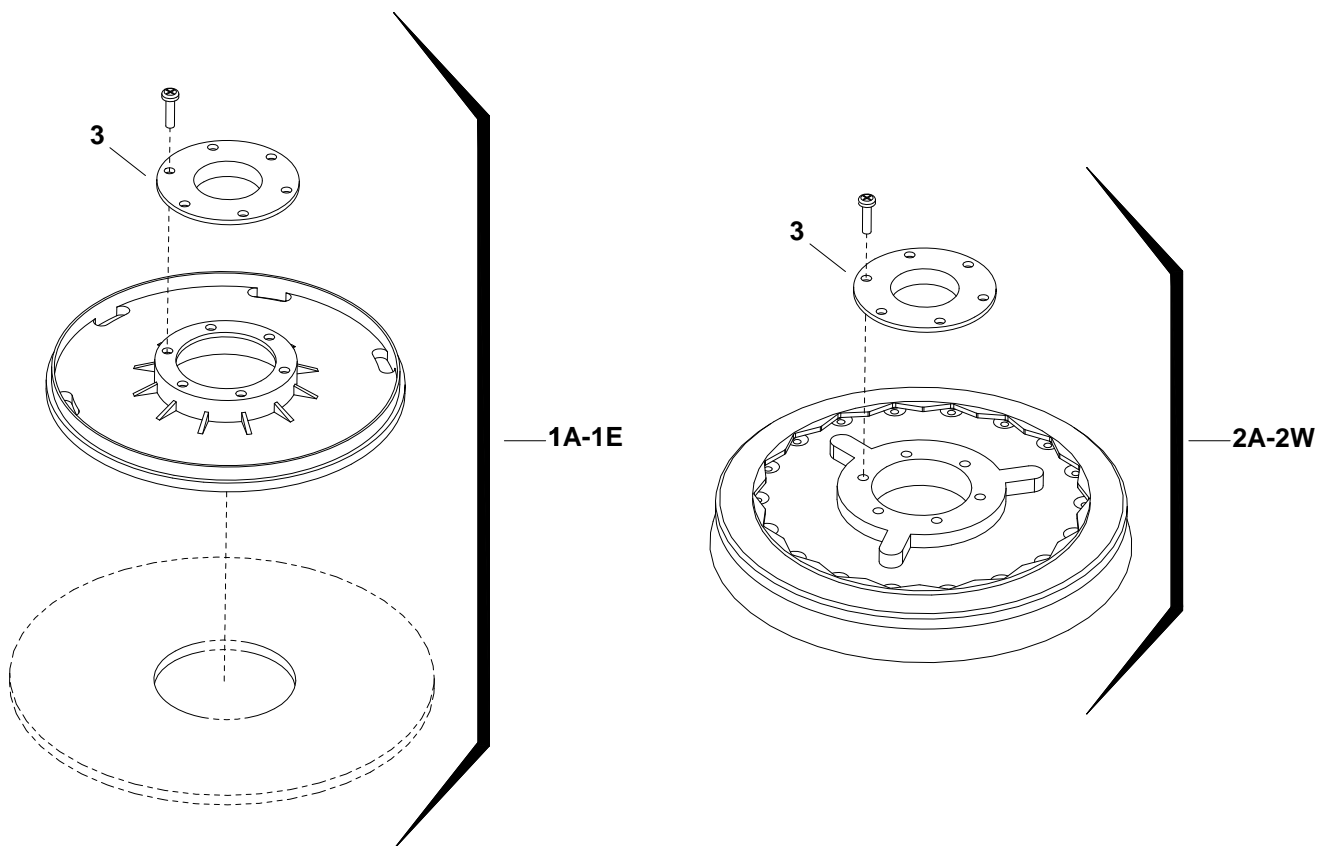

## BRUSH/PAD DRIVER GROUP

REF	PART NO.	PRV NO.	QTY	DESCRIPTION	SERIAL NO. FROM	NOTES:
1A	86284280	02216	-	PAD DRIVER, 13" POLISHER		
1B	86284330	02396	-	PAD DRIVER, 15" POLISHER		
1C	86000120	02218	-	PAD DRIVER, 17" POLISHER		
1D	86284290	02217	-	PAD DRIVER, 19" HS		
1E	86284300	02219	-	PAD DRIVER, 20" POLISHER		
2A	86283720	02232	-	BRUSH, 13" NYL.POL. W/CLT.PLT		
2B	86283730	02233	-	BRUSH, 13" NYL.SCRUB W/CLT.PLT		
2C	86283740	02234	-	BRUSH, 13" MILD GRIT W/CLT.PLT		
2D	86283750	02235	-	BRUSH, 13" AGG. GRIT W/CLT.PLT		
2E	86283760	02236	-	BRUSH, 13" POLYPRO W/CLT. PLT		
2F	86230480	02447	-	BRUSH, 15" NYL.POL. W/CLT.PLT		
2G	86230490	02448	-	BRUSH, 15" NYL. SCRUB W/CLT.PLT		
2H	86230460	02445	-	BRUSH, 15" MILD GRIT W/CLT.PLT		
2J	86230450	02444	-	BRUSH, 15" AGG.GRIT W/CLT.PLT		
2K	86230470	02446	-	BRUSH, 15" PLOYPRO W/CLT.PLT		
2L	86000140	02242	-	BRUSH, 17" NYL. POL. W/CLT.PLT		
2M	86283800	02240	-	BRUSH, 17" NYL.SCRUB W/CLT.PLT		
2N	86000130	02241	-	BRUSH, 17" MILD GRIT W/CLT.PLT		
2P	86283710	02205	-	BRUSH, 17" AGG. MALGRIT W/C.P		
2Q	86000110	02206	-	BRUSH, 17" POLYPRO W/CLT. PLT		
2R	86283790	02239	-	BRUSH, 20" NYL.POL.W/CLT.PLT.SFT		
2T	86283770	02237	-	BRUSH, 20" NYL.SCRUB W/CLT.PLT		
2U	86283780	02238	-	BRUSH, 20" MILD GRIT W/CLT.PLT		
2V	86283690	02202	-	BRUSH, 20" AGG. MALGRIT W/C.P.		
2W	86283700	02203	-	BRUSH, 18" POLYPRO W/CLT. PLT		
3	86284350	02220	-	PLATE, PAD CLUTCH		

# FRAME GROUP

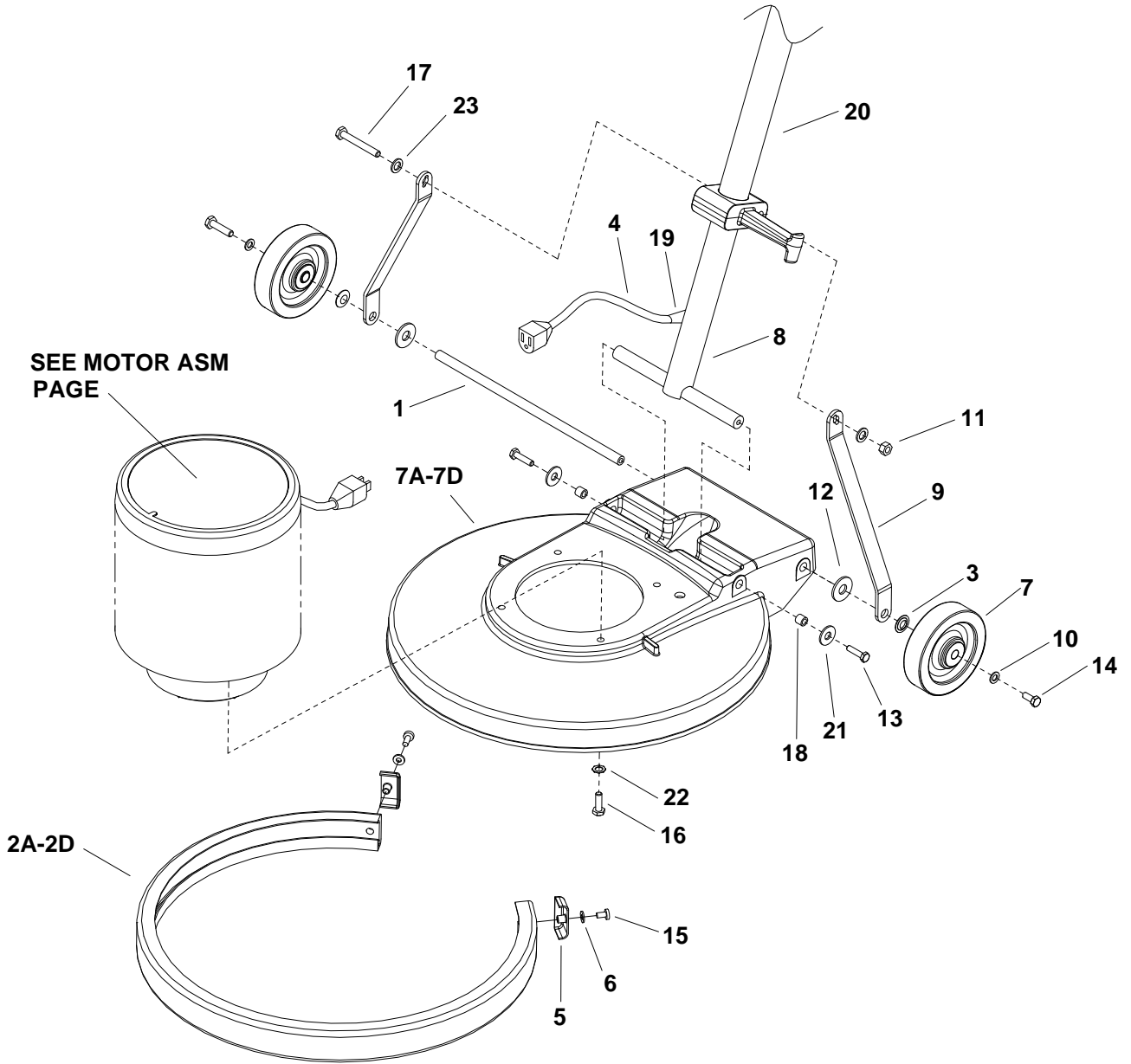

## FRAME GROUP

REF	PART NO.	PRV NO.	QTY	DESCRIPTION	SERIAL NO. FROM	NOTES:
1	86214930	03111	1	AXLE, MAIN POLISHER		
2A	86216230	14341	-	BUMPER, EXTRUSION 30.5"		SP13
2B	86216330	14371	-	BUMPER, EXTRUSION 37.3"		SP15
2C	86216340	14372	-	BUMPER, EXTRUSION 43.8"		U17, U17X, SPT17, SP17, SP17X
2D	86216350	14373	-	BUMPER, EXTRUSION 53.4"		U20, U20X, UDS20, SPT20X, SP20, SP20X, SPDS20
3	86222270	57276	2	NUT, PUSH FLAT RD .51D		
4	86216920	23206	1	CORDSET, 14/3 X 47", SJT, BLK		
5	86216600	27871	2	CAP, EXTRUSION		
6	86137340	87211	2	WASHER, M6 FLAT BLK		
7A	86288430	29211	-	DECK, 13 IN POLISHER, BLUE		SP13
7B	86288440	29212	-	DECK, 15 IN POLISHER, BLUE		SP15
7C	86217600	29213		DECK, 17 IN POLISHER, BLUE		SPT17, SP17, SP17X
7D	86217610	29214BLUE		DECK, 20 IN POLISHER, BLUE		SPT20X, SP20, SP20X, SPDS20
7E	86288960	29213GRY	-	DECK, 17 IN POLISHER, GRAY		U17, U17X, BDS 43/175 C
7F	86288970	29214GRY	-	DECK, 20 IN POLISHER, GRAY		U20, U20X, UDS20, BDS 51/175-300 C, BDS 51/175 C
8	86218440	38290	1	HANDLE, POLISHER		
9	86221860	51328	2	LINK, HANDLE ADJUST		
10	86226020	89206	2	WHEEL, 5D X 1.25 X 13MMID GRY		
11	86136360	57275	1	NUT, M10X1.5 HEX NYLOK PLTD		
12	86225720	87203	2	WASHER, 14MMID X 36MMOD		
13	86274230	70135	2	SCR, M8 X 30 HHMS		
14	86136640	70262	2	SCR, M8 X 20 HHMS PLTD		
15	86276570	70691	2	SCR, M6 X 25 HHMS BLK		
16	86136710	70698	4	SCR, 5/16-18 X 3/4 HHCS GR5 BLK		
17	86136720	70701	1	SCR, M10 X 90 HHMS		
18	86224290	730008	2	SPACER, .317ID X .5OD X .44LG		
19	86224930	730012	1	STRAIN RELIEF, 14/3 STRAIGHT		
20	86225380	78447	1	TUBE ASSY, HANDLE ADJ		
21	86137280	87054	2	WASHER, M8 FLAT DIN125A PLT		
22	86279090	87067	4	WASHER, 5/16 LOCK INT STAR PLT		
23	86010720	87086	2	WASHER, M10 X 30 PLTD		

# MOTOR GROUP

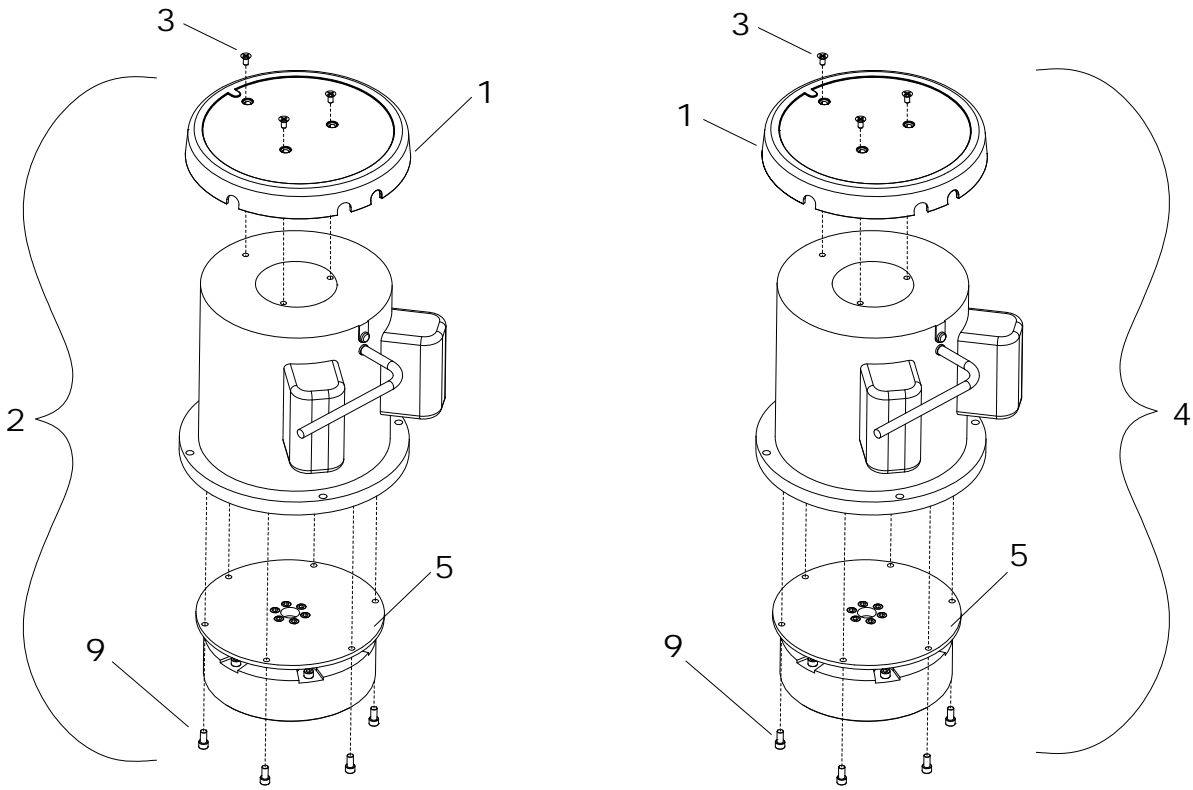

SP13, SP15, SP17, SP20,  
SPT17, SPT20X, SPT17,  
U17, U20, BDS 43/175 C

SP17X, SP20X, SPT20X,  
U17X, U20X,  
BDS 51/175 C

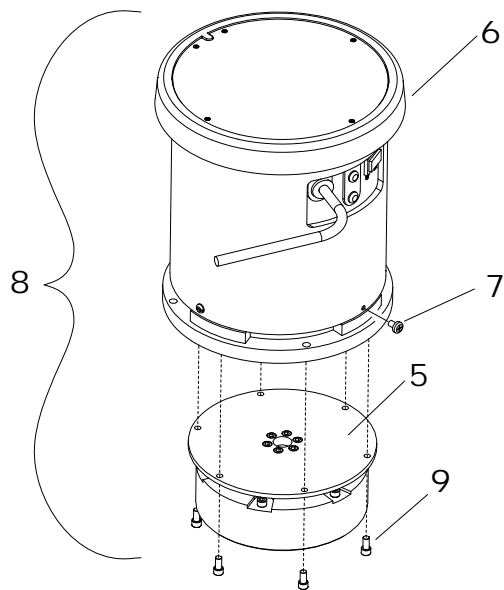

SPDS20, UDS20, BDS 51/175-300 C

## MOTOR GROUP

REF	PART NO.	PRV NO.	QTY	DESCRIPTION	SERIAL NO. FROM	NOTES:
1	86217490	27884	1	COVER, MOTOR		
2	86222090	53263	1	MOTOR, 1 HP 115V INDUCTION		W/ COVER
3	86223690	70702	3	SCR, M5 X .8 X 15MM FHMS BLK		
4	8622210	53264	1	MOTOR, 1.5 HP 115 INDUCTION		W/ COVER
5	86223030	62917	1	PLATE, ADAPTER MP MOTOR		
6	86217500	27892	1	COVER ASM, MOTOR, 1.75 HP		
7	86223680	70700	8	SCR, M5 X .8 X 10MM PHMS BLK		
8	86222070	53253	1	MOTOR, 115V 1.75 HP 175/300RPM		W/ COVER
9	86263700	70723	6	SCR, M5 X .8 X 15MM SHCSM		

### MOTOR COMPONENTS (NOT SHOWN)

PART NO.	PRV NO.	QTY	DESCRIPTION	SERIAL NO. FROM	NOTES:
86216710	140411	1	CIRCUIT BREAKER, 20 AMP		(SP13,15,17,17X,20,20X) (U17, U20,U17X,U20X)(BDS 43/175 C, BDS 51/175 C)
86216700	140401	1	CIRCUIT BREAKER, 30 AMP		(SPDS20)(UDS20) (BDS 51/175-300 C)
86223390	67488	1	RECTIFIER		(SPDS20)(UDS20) (BDS 51/175-300 C)
86001820	14404	1	BRUSH SET MP MOTOR (PKG OF 4)		(SPDS20)(UDS20) (BDS 51/175-300 C)
86003660	34378	1	FUSE		(SP13,15,17,17X,20,20X, SPDS20) (UDS20) (BDS 43/175 C, BDS 51/175 C)
86003670	34379	1	FUSE HOLDER		(SP13,15,17,17X,20,20X, SPDS20) (UDS20) (BDS 43/175 C, BDS 51/175 C)
86001020	09135	2	BEARING, MOTOR		
86135540	27352	1	COUPLING, MTR/GEAR BOX		
86225170	730039	1	SWITCH ASM		(SPDS20)(UDS20) (BDS 51/175-300 C)
86215410	140416	1	BOOT, CIRCUIT BREAKER		
86223510	67489	1	RING, MOTOR SHAFT		
86214740	05176	1	ARMATURE, MOTOR REPAIR 53253		(SPDS20)(UDS20) (BDS 51/175-300 C)
86002650	270061	1	CAPACITOR, RUN 30UF		(SP13,15,17,17X,20,20X) (U17, U20,U17X,U20X) (BDS 43/175 C, BDS 51/175 C)
86216610	270062	1	CAPACITOR, START 340UF		(SP13,15,17,17X,20,20X) (U17, U20,U17X,U20X) (BDS 43/175 C, BDS 51/175 C)
86216650	72182	1	CENTRIFUGAL WEIGHT ASSEMBLY		(SP13,15,17,17X,20,20X) (U17, U20,U17X,U20X) (BDS 43/175 C, BDS 51/175 C)
86224890	72183	1	STATIONARY END CAP SWITCH		(SP13,15,17,17X,20,20X) (U17, U20,U17X,U20X) (BDS 43/175 C, BDS 51/175 C)

PRIOR TO SERIAL # \* (NOT SHOWN)

PART NO.	PRV NO.	QTY	DESCRIPTION	SERIAL NO. FROM	NOTES:
86222040	53243	1	MOTOR, 115V 1.25 HP 175RPM		U17, U20
86222050	53244	1	MOTOR, 115V 1.75 HP 175RPM		U17X, U20X
86222070	53253	1	MOTOR, 115V 1.75 HP 175/300RPM		UDS20
86214720	05174	1	ARMATURE, MOTOR REPAIR 53243		U17, U20
86214730	05175	1	ARMATURE, MOTOR REPAIR 53244		U17X, U20X

# HANDLE GROUP

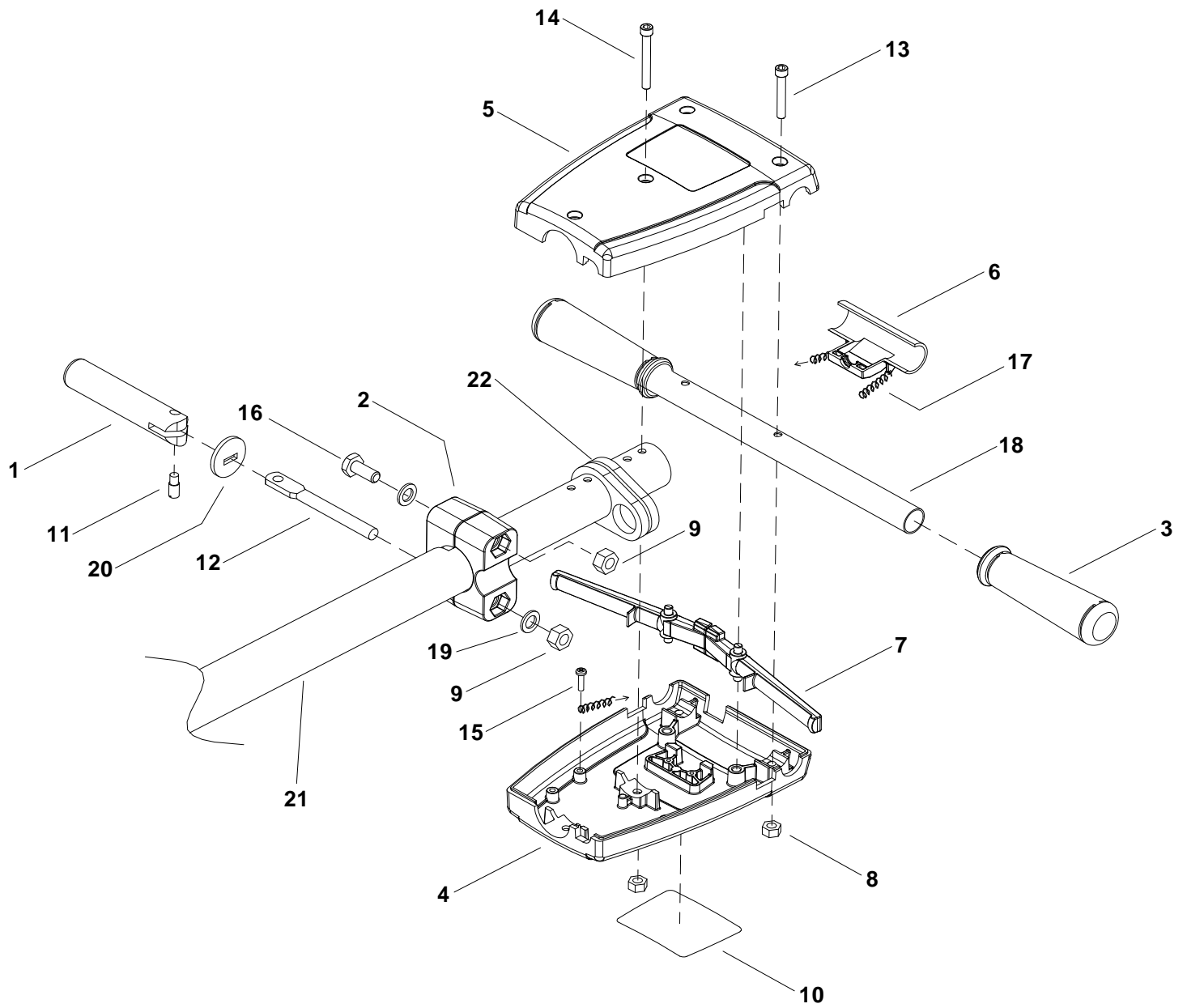

## HANDLE GROUP

REF	PART NO.	PRV NO.	QTY	DESCRIPTION	SERIAL NO. FROM	NOTES:
1	86215130	14344	1	BAR, HANDLE ADJUST		
2	86215380	140393	1	BLOCK, HANDLE MOUNT		
3	86004070	36196	2	GRIP, POLISHER HANDLE		
4	86219320	41363	1	HOUSING, POLISHER HANDLE REAR		
5	86219330	41366	1	HOUSING, POLISHER HANDLE FRONT		
6	86005150	51326	1	LOCK, SAFETY		
7	86005160	51327	1	LEVER, SWITCH		
8	86136350	57274	4	NUT, M6X1 HEX BLK		
9	86136360	57275	1	NUT, M10X1.5 HEX NYLOK PLTD		
10	86219740	500194	1	LABEL, WARNING		
11	86222560	66334	1	PIN, PIVOT, HANDLE ADJUSTMENT		
12	86223550	67430	1	ROD, HANDLE ADJUST		
13	86136670	70686	2	SCR, M6 X 45 SHCS BLK		
14	86136680	70687	2	SCR, M6 X 50 SHCS BLK		
15	86288450	70689	1	SCR, M4.8 X 10 HHTF TYPE B		
16	86136700	70692	1	SCR, M10 X 75 HHCS PLTD		
17	86224740	73990	2	SPRING, EXT, .50D X 3.5L		
18	86225370	78437	1	TUBE, GRIP HANDLE		
19	86010720	87086	2	WASHER, M10 X 30 PLTD		
20	86225710	87202	1	WASHER, BEARING (HANDLE ADJ)		
21	86225380	78447	1	TUBE ASSY, HANDLE ADJ		
22	86216370	14434	1	BUMPER, HANDLE		

# WIRING GROUP

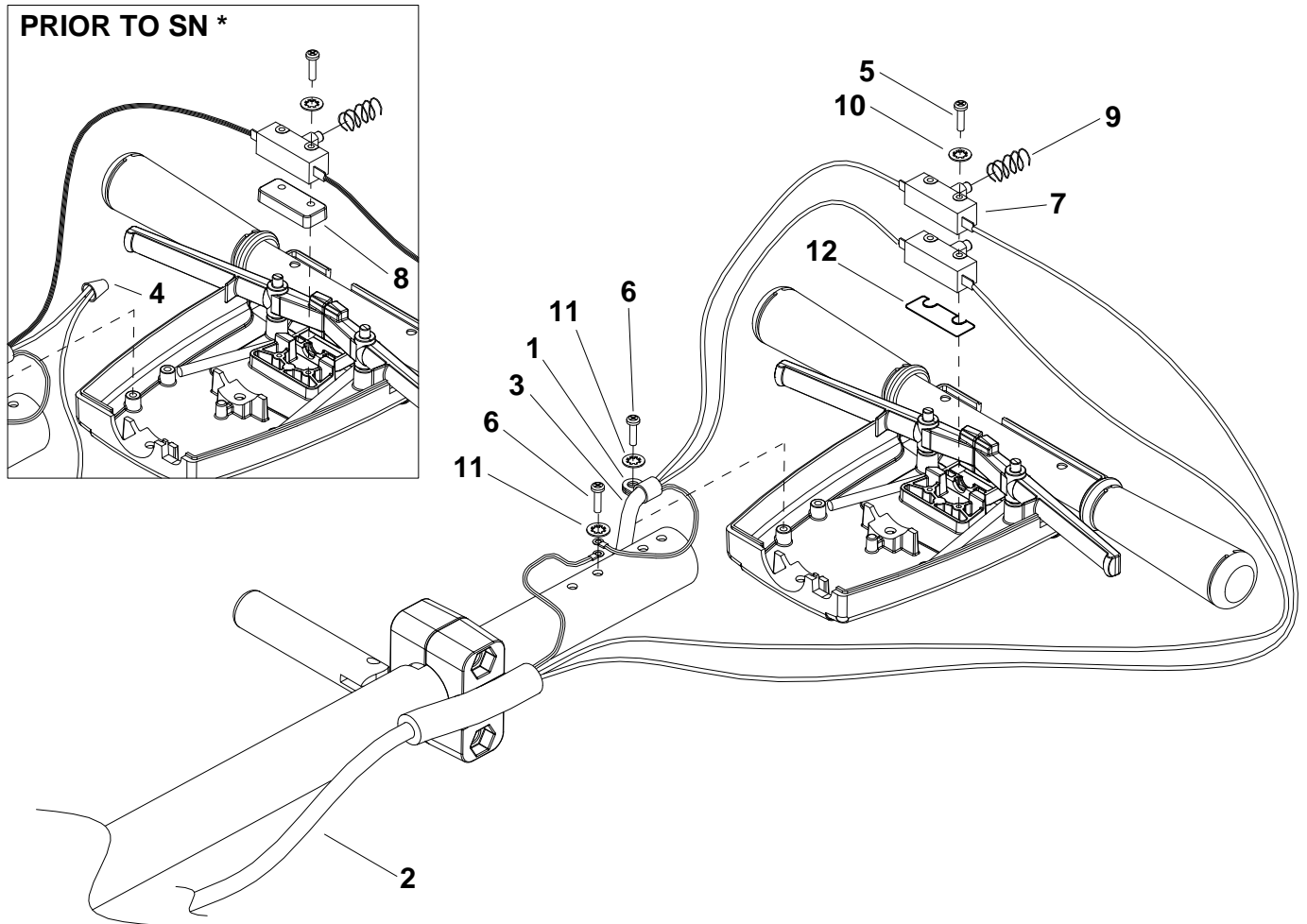

**WIRING GROUP**

REF	PART NO.	PRV NO.	QTY	DESCRIPTION	SERIAL NO. FROM	NOTES:
1	86233170	20054	1	CLAMP, 3/8 NYLON UL/CSA		
2	86234150	23167	1	CORD SET, 14/3 ST X 50' YLW		
3	86216920	23206	1	CORDSET, 14/3 X 47", SJT, BLK		
4	86247920	57069	1	NUT, ORG WIRE (2-5 18G/2-14G)		
5	86136780	70801	2	SCR, M3.5 X 40 PHTF TYPE B	10020019	WAS 70688
6	86288450	70689	2	SCR, M4.8 X 10 HHTF TYPE B		
7	86007110	72123	2	SWITCH, 25A SPST 125-250V SNAP	10020019	WAS QTY 1
8	86224550	73989	1	SPACER, SWITCH POLISHER		
9	86224750	73993	1	SPRING, COMP, .48OD X .91L		
10	86137290	87057	2	WASHER, M4 SHAKEPROOF		
11	86137330	87208	2	WASHER, M5 SHAKEPROOF PLTD		
12	86215140	140674	1	BARRIER SHEET	10020019	

## WIRING DIAGRAM

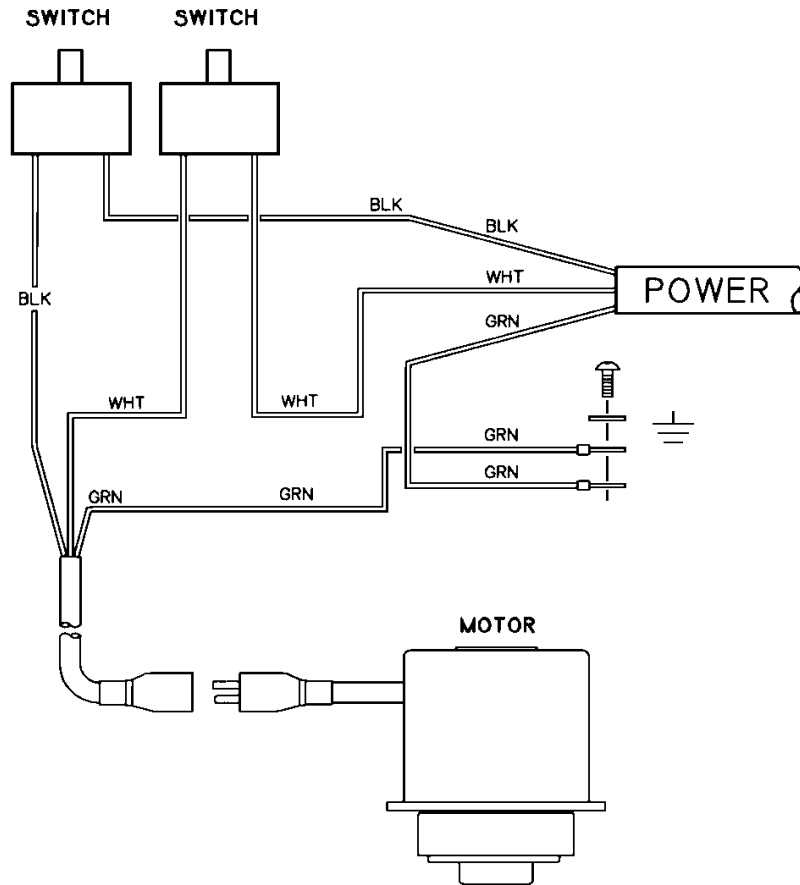

## SUGGESTED SPARE PARTS

PART NO.	PRV NO.	DESCRIPTION	SERIAL NO. FROM	NOTES:
86225710	87202	WASHER, BEARING (HANDLE ADJ)		
86224740	73990	SPRING, EXT .5 OD X 3.5L		
86224750	73993	SPRING, COMP .48 OD X .91 L		
86007110	72123	SWITCH, 25A SPST 125-250V SNAP		
86215130	14344	BAR, HANDLE ADJ		
86222560	66334	PIN, PIVOT, HANDLE ADJ		
86223550	67430	ROD, HANDLE ADJ		
86003660	34378	FUSE		(SP13,15,17,17X,20,20X, SPDS20) (UDS20) (BDS 43/175 C, BDS 51/175 C, BDS 51/175-300 C)
86003670	34379	FUSE HOLDER		(SP13,15,17,17X,20,20X, SPDS20) (UDS20) (BDS 43/175 C, BDS 51/175 C, BDS 51/175-300 C)
86135540	27352	COUPLING, MTR/GEAR BOX PLSHER		(SPDS20) (UDS20) (BDS 51/175-300 C)
86223390	67488	RECTIFIER, 50A 600V BRIDGE		(SPDS20) (UDS20) (BDS 51/175-300 C)
86216700	140401	CIRCUIT BREAKER, 30AMP MPX		(SPDS20) (UDS20) (BDS 51/175-300 C)
86216710	140411	CIRCUIT BREAKER, 20AMP MP/MB		(SP13,15,17,17X,20,20X) (U17, U20, U17X,U20X) (BDS 43/175 C, BDS 51/175 C)



