



# KÄRCHER®

500 PSI-13 Gallon

Operating instructions (ENG)

**MODEL:**

**PUZZI 50/35  
10066720**

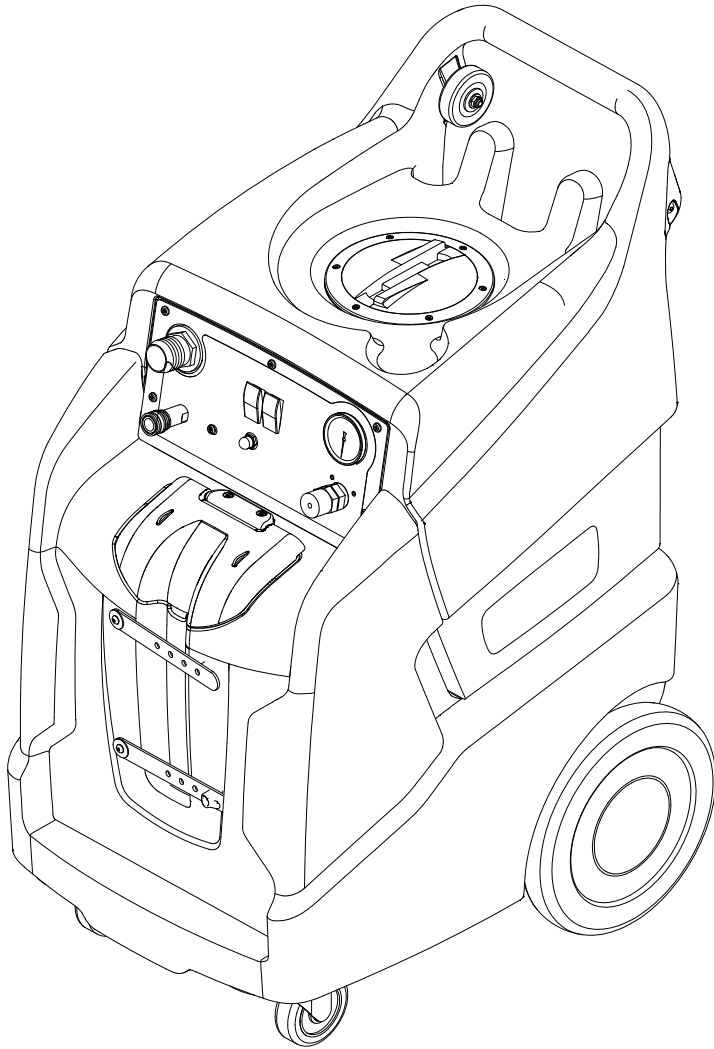

Read these instructions before using the machine.

 **CLICK TO ORDER PARTS**



Model: \_\_\_\_\_  
Date of Purchase: \_\_\_\_\_  
Serial Number: \_\_\_\_\_  
Dealer: \_\_\_\_\_  
Address: \_\_\_\_\_  
Phone Number: \_\_\_\_\_  
Sales Representative: \_\_\_\_\_

**OVERVIEW**

The machine is an electric powered carpet extractor intended for commercial use. This appliance applies a cleaning solution to the carpet and then vacuums the soiled water back into the recovery tank.

<b>Machine Data Log / Overview</b> .....	<b>2</b>	<i>PARTS</i>	
<b>Table of Contents</b> .....	<b>3</b>	Control Panel .....	20
<b>How to Use This Manual</b> .....	<b>4</b>	Electrical .....	22
		Frame .....	24
<i>Safety</i>		Labels .....	26
IMPORTANT SAFETY INSTRUCTIONS .....	5	Pump .....	28
HAZARD INTENSITY LEVEL .....	6	Recovery .....	30
Safety Labels .....	7	Solution .....	32
Grounding Instructions .....	8	Vacuum .....	34
		Wiring .....	36
		Suggested Spare Parts .....	38
		Serial Numbers .....	39
<i>Operations</i>			
Technical Specifications .....	9		
Controls .....	10		
<b>Machine Operation</b> .....	<b>11</b>		
Chemicals .....	11		
Pre-Run Inspection .....	12		
Equipment Set-up .....	12		
Cleaning .....	13		
<i>Maintenance</i>			
Periodic Maintenance .....	14		
Daily/Regular Maintenance .....	14		
Vacuum Motor Replacement .....	15		
Solution Pump Replacement .....	16		
Pressure Regulator .....	17		
Troubleshooting .....	18		

## How to Use This Manual

This manual contains the following sections:

- How to Use This Manual
- Safety
- Operations
- Maintenance
- Parts List

The HOW TO USE THIS MANUAL section will tell you how to find important information for ordering correct repair parts.

Parts may be ordered from authorized dealers. When placing an order for parts, the machine model and machine serial number are important. Refer to the MACHINE DATA box which is filled out during the installation of your machine. The MACHINE DATA box is located on the inside of the front cover of this manual.

Model:	_____
Date of Purchase:	_____
Serial Number:	_____
Dealer:	_____
Address:	_____
Phone Number:	_____
Sales Representative:	_____

The model and serial number of your machine is located approximately where shown.

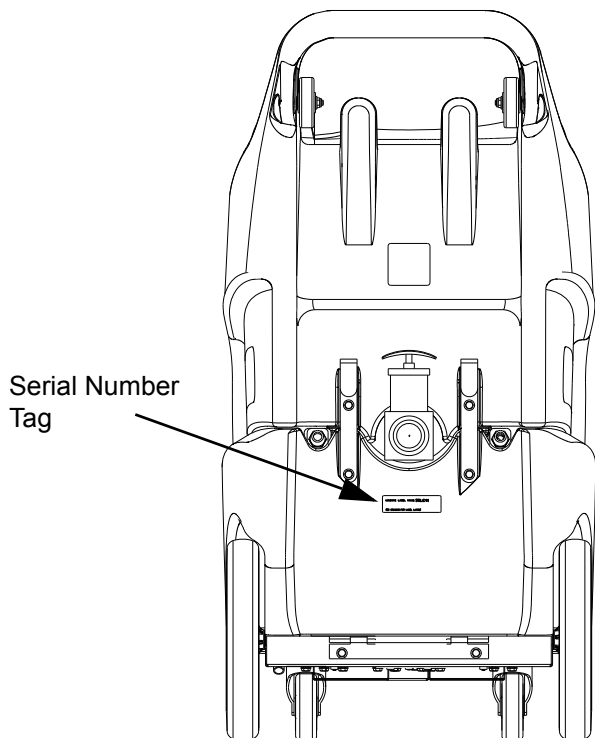

The SAFETY section contains important information regarding hazardous or unsafe practices of the machine. Levels of hazards are identified that could result in product damage, personal injury, or severe injury resulting in death.

The OPERATIONS section is to familiarize the operator with the operation and function of the machine.

The MAINTENANCE section contains preventive maintenance to keep the machine and its components in good working condition. They are listed in this general order:

- Maintenance
- Lubrication
- Vacuum Motor Replacement
- Solution Pump Replacement
- Troubleshooting

The PARTS LIST section contains assembled parts illustrations and corresponding parts list. The parts lists include a number of columns of information:

- **REF** – column refers to the reference number on the parts illustration.
- **PART NO.** – column lists the part number for the part.
- **PRV NO.** – reference number.
- **QTY** – column lists the quantity of the part used in that area of the machine.
- **DESCRIPTION** – column is a brief description of the part.
- **SERIAL NO. FROM** – If this column has an (\*) and a Reference number, see the SERIAL NUMBERS page in the back of your manual. If column has two asterisk (\*\*), call manufacturer for serial number. The serial number indicates the first machine the part number is applicable to. The main illustration shows the most current design of the machine. When a boxed illustration is shown, it displays the older design.
- **NOTES** – column for information not noted by the other columns.

**NOTE:** If a service or option kit is installed on your machine, be sure to keep the **KIT INSTRUCTIONS** which came with the kit. It contains replacement parts numbers needed for ordering future parts.

**NOTE:** The manual part number is located on the lower left corner of the front cover.

# IMPORTANT SAFETY INSTRUCTIONS

When using an electrical appliance, basic precaution must always be followed, including the following:

**READ ALL INSTRUCTIONS BEFORE USING THIS MACHINE.**

This machine is for commercial use.

**⚠ WARNING:** To reduce the risk of fire, electric shock, or injury:

Connect to a **properly grounded outlet**. See Grounding Instructions.

**Do not** leave the machine unattended. Unplug machine from outlet when not in use and before maintenance or service.

**Use only** indoors. Do not use outdoors or expose to rain.

**Do not** allow machine to be used as a toy. **Close attention** is necessary when used by or near children.

Use only as described in this manual. Use only manufacturer's recommended components and attachments.

Do not use damaged electrical cord or plug. Follow all instructions in this manual concerning grounding the machine. If the machine is **not working properly**, has been dropped, damaged, left outdoors, or dropped into water, return it to an authorized service center.

**Do not** pull or carry machine by electrical cord, use as a handle, close a door on cord, or pull cord around sharp edges or corners.

**Do not** run machine over cord. **Keep** cord away from heated surfaces.

**Do not** unplug machine by pulling on cord. To unplug, grasp the electrical plug, not the electrical cord.

**Do not** handle the electrical plug or machine with wet hands.

**Do not** operate the machine with any openings blocked. Keep openings free of debris that may reduce airflow.

This machine is intended for cleaning carpet only.

**Do not** vacuum anything that is burning or smoking, such as cigarettes, matches, or hot ashes.

This machine is not suitable for picking up health endangering dust.

Turn off all controls before unplugging.

**Machine can cause a fire** when operating near flammable vapors or materials. Do not operate this machine near flammable fluids, dust or vapors.

**This machine is suitable for commercial use, for example in hotels, schools, hospitals, factories, shops and offices for more than normal housekeeping purposes.**

Maintenance and repairs must be done by qualified personnel.

If foam or liquid comes out of machine, switch off immediately.

## SAVE THESE INSTRUCTIONS

The following symbols are used throughout this guide as indicated in their descriptions:

### HAZARD INTENSITY LEVEL

There are three levels of hazard intensity identified by signal words -**WARNING** and **CAUTION** and **FOR SAFETY**. The level of hazard intensity is determined by the following definitions:

#### **WARNING:**

**WARNING** - Hazards or unsafe practices which COULD result in severe personal injury or death.

#### **CAUTION:**

**CAUTION** - Hazards or unsafe practices which could result in minor personal injury or product or property damage.

**FOR SAFETY: To Identify actions which must be followed for safe operation of equipment.**

Report machine damage or faulty operation immediately. Do not use the machine if it is not in proper operating condition. Following is information that signals some potentially dangerous conditions to the operator or the equipment. Read this information carefully. Know when these conditions can exist. Locate all safety devices on the machine. Please take the necessary steps to train the machine operating personnel.

#### **FOR SAFETY:**

##### **DO NOT OPERATE MACHINE:**

Unless Trained and Authorized.

Unless Operation Guide is Read and understood.

In Flammable or Explosive areas.

In areas with possible falling objects.

##### **WHEN SERVICING MACHINE:**

**Avoid moving parts. Do not wear loose clothing; jackets, shirts, or sleeves when working on the machine.**

**Use only manufacturer approved replacement parts.**

## Safety Labels

**NOTE: These drawings indicate the location of safety labels on the machine. If at any time the labels become illegible, promptly replace them.**

Label Warning  
86333370

CAUTION - Risk of Electric Shock - More Than One Disconnect Switch May Be Required To Disconnect All Power.  
 WARNING - Risk Of FIRE OR Explosion - DO NOT USE OR PICK UP FLAMMABLE LIQUIDS.  
 WARNING - Risk Of Injection To Persons - Do Not Direct Discharge Stream At Persons.  
 LA PRUDENCE - le Risque de Décharge Electrique - Plus Que l'Un Débrancher mai de Commutateur Est Exigé Débrancher Tout Pouvoir  
 AVERTISSANT - le Risque De FEU OU D'Explosion - N'UTILISEZ pas OU CAMION INFLAMMABLE LIQUIDES  
 LAVERTISSEMENT - la Risque d'Injection ou la Blessure aux personnes - ne dirige pas le ruisseau de décharge aux personnes

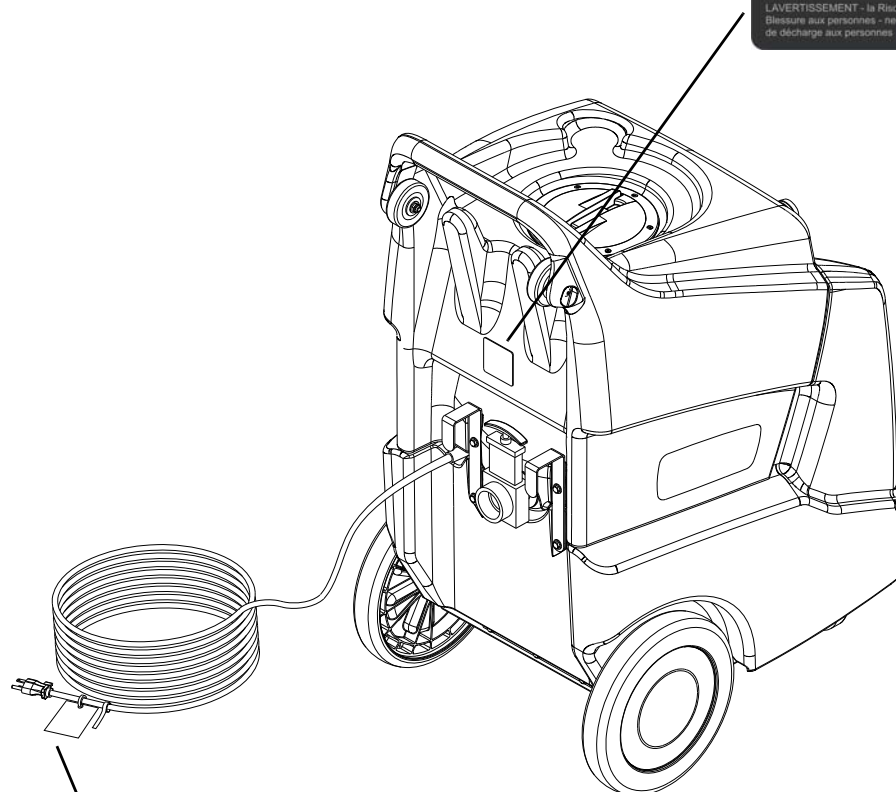

**\*WARNING RISK OF ELECTROCUTION - DO NOT REMOVE THIS TAG\***  
 1. Connect Only To Properly Grounded Outlet. Do Not Remove Ground Pin  
 2. Inspect Cord Before Using - Do Not Use If Cord Is Damaged  
 3. Keep All Connections Dry And Off The Ground  
 4. Do Not Touch Plug With Wet Hands  
 5. This Product Is Provided With A Ground Fault Circuit Interrupter Built Into The Power Cord Plug. If Replacement Of The Plug Or Cord Is Needed, Use Only Identical Replacement Parts.  
 6. Read Instruction Manual Before Using

LE RISQUE D'AVERTISSEMENT D'ELECTROCUTION - n'ENLEVE pas CETTE ETIQUETTE  
 1. Connecter Seulement A la Sortie Convenablement Fondée. Ne Pas Enlever l'Epingle de Sol  
 2. Inspecter la Corde avant qu'il/elle - n'utilisez pas Si Corde Etre A Endommagé  
 3. Garder Toutes Connexions Sécher Et Du Sol  
 4. Ne Pas Toucher le Bouchon Avec les Mains Mouillées  
 5. Ce Produit Est Fourni Avec Un Sol Un Défaut Circuit Interrupteur A Intégré Dans Le Bouchon de Cordon d'alimentation. Si le Remplacement Du Bouchon Ou Corde Etre nécessaire, l'usage Remplacement Seulement Identique Sépare  
 6. Lire le Manuel d'Instruction Avant Utiliser

Label Circuit Interrupter  
86333380

## Grounding Instructions

**THIS PRODUCT IS FOR COMMERCIAL USE ONLY.**

### ELECTRICAL:

In the USA this machine operates on a standard 15 amp 115V, 60 hz, A.C. power circuit. The amp, hertz, and voltage are listed on the data label found on each machine. Using voltages above or below those indicated on the data label will cause serious damage to the motors.

### EXTENSION CORDS:

If an extension cord is used, the wire size must be at least one size larger than the power cord on the machine, and must be limited to 50 feet (15.5m) in length.

### GROUNDING INSTRUCTIONS:

This appliance must be grounded. If it should malfunction or break down, grounding provides a path of least resistance for electric current to reduce the risk of electric shock. This appliance is equipped with a cord having an equipment-grounding conductor and grounding plug. The plug must be inserted into an appropriate outlet that is properly installed and grounded in accordance with all local codes and ordinances.

This appliance is for use on a nominal 120-volt circuit, and has a grounded plug that looks like the plug in "Fig. A". A temporary adaptor that looks like the adaptor in "Fig. C" may be used to connect this plug to a 2-pole receptacle as shown in "Fig. B", if a properly grounded outlet is not available. The temporary adaptor should be used only until a properly grounded outlet (Fig. A) can be installed by a qualified electrician. The green colored rigid ear, lug, or wire extending from the adaptor must be connected to a permanent ground such as a properly grounded outlet box cover. Whenever the adaptor is used, it must be held in place by a metal screw.

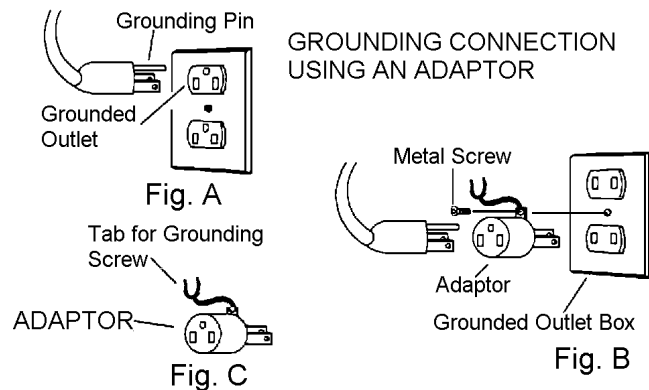

Note: Adaptors are not allowed in Canada.

## **⚠ WARNING:**

**Improper connection of the equipment-grounding conductor can result in a risk of electric shock. Check with a qualified electrician or service person if you are in doubt as to whether the outlet is properly grounded. Do not modify the plug provided with the appliance - if it will not fit the outlet, have a proper outlet installed by a qualified electrician.**

## Technical Specifications

ITEM	MEASURE
Electrical	115 Volt, 60 hz, 15A
Solution Pump	500 psi
Solution Capacity	13 Gal
Recovery Capacity	11 Gal
Height	43 inches
Length	30 inches
Width	22 inches
Vacuum Motor	Single 3 Stage
Weight- Empty	117 lbs
Weight-Full Solution	222 lbs
Power cord	1 X 40 feet inline GFCI

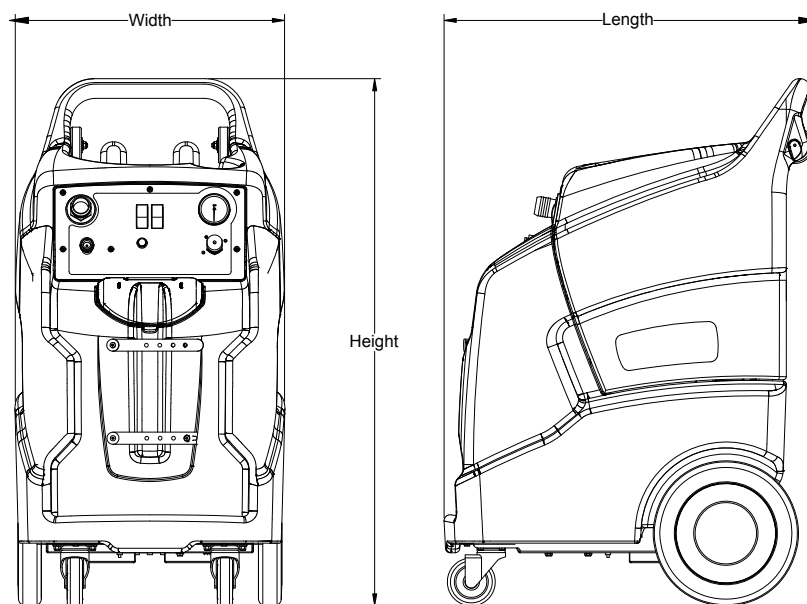

Controls

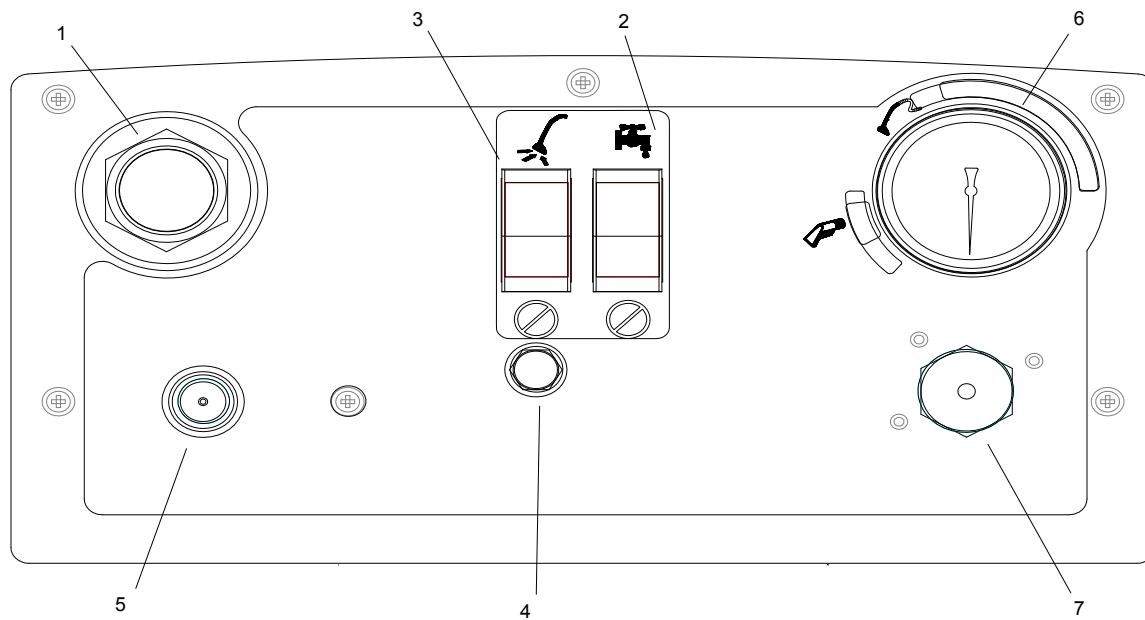

1. Vacuum Accessory Tool Hook-up
2. Solution Pump Switch
3. Vacuum 1 Switch
4. Breaker for Vacuum 1
5. Solution Accessory Tool Hook-up
6. Pressure Gauge
7. Adjustable Pressure Relief Valve

## Machine Operation

### **⚠ WARNING:**

Care must be exercised in the use of all chemicals. Chemicals are poisonous and can pose a health risk. Read and follow manufacturers instructions regarding dangers and correct usages.

### **⚠ CAUTION:**

The internal parts of the pump used in the machine are suitable for use with most carpet cleaning chemicals. But they are susceptible to chemical attack from some cleaning substances, such as hydrocarbon solvents and chlorinated bleaches. These non-compatible materials are not of the type used for carpet cleaning.

Only use chemicals approved for use with this machine. Use of non-compatible chemicals may cause machine damage and will not be covered under the warranty. Carefully read ingredients on manufacturer's label before using any product in this machine.

### **⚠ WARNING:**

Do not let pump run dry.

### **⚠ WARNING:**

Do not let pump run unattended.

## Chemicals

### Suitable Chemicals

- Alkalis
- Detergents
- Hydroxides
- Soaps
- Vinegar

### Non-Compatible

- Aldehydes
- Aromatics Hydrocarbons
- SP Butyls
- Carbon Tetrachloride
- Clorox\*
- Chlorinated Bleaches
- Chlorinated Hydrocarbons
- Lysol\*
- Methyl Ethel Ketone (MEK)
- Perchorethylene (perc)
- Phenolics
- Trichlorethylene
- D-Limonene

\*Registered Trademark

## Operations

---

### Pre-Run Inspection

1. Check all fittings and connectors for proper assembly.
2. Check all hoses for leaks. Repair or replace any damaged hoses.
3. Check power cord(s) for any damage. If damaged, replace.

### Equipment Set-up

1. Plug power cord from machine into properly grounded wall outlet.
2. Turn vacuum motor switch on and off to make sure there is electrical power at machine.
3. Using a clean container, fill the solution tank with clean hot water. Do not use water over 130°F. Mix in a non-foaming cleaning concentrate for use in hot water extraction machines, following the manufacturer's instructions printed on container.

4. Connect priming hose to solution fitting on machine. Turn on pump and run for 30 seconds or until a steady flow of water is coming out of priming hose. Turn off pump and disconnect priming hose.
5. Connect vacuum hose to machine. Slide the swivel cuff over the outlet on the tank.
6. Connect the hose to your machine and wand. Pull back the knurled collar on the quick disconnect coupler and push onto the connection on the chassis. To avoid leaks, check to be that a positive connection was made.

**NOTE:** *When using a powder cleaner, pre-mix with hot water in a clean container before adding to the solution tank.*

7. Turn pump and vacuum switch to the on position.

## Cleaning

### **⚠ WARNING:**

**Always use defoamer if foaming occurs. Foam will suspend large particles that may damage vacuum(s) as well as allow liquid into the vacuum motor(s) without activating the float shutoff.**

1. Prior to cleaning, make certain that the nozzle is functioning properly.
  - a. To check, hold the wand about one foot above the surface to be cleaned and open the wand valve. A full spray should be observed from the nozzle.
  - b. If the nozzle is not showing a full spray pattern, adjust nozzle for proper pattern, clean, or replace nozzle.
2. Normally, chemical is applied on the push stroke of the wand when cleaning. Vacuuming is done on the pull stroke. For heavily soiled carpets the wand may be used in a scrubbing manner, applying chemical in both the push and pull stroke.
3. When cleaning, keep the working opening (wand mouth) flat on the surface being cleaned. Keep the wand moving when the valve is open.
4. The shutoff float inside the vacuum tank will impede the vacuum flow when the vacuum tank is full. When this occurs, empty the vacuum tank by opening the dump valve and dispose of the waste in a proper manner.
5. Once the vacuum tank has been emptied, you may once again proceed with cleaning

**Periodic Maintenance**

Twice a month, flush a white vinegar solution (one quart vinegar to two gallons of water) or anti-browning solution (mixed as directed) through the machine. This will prevent build-up of alkaline residue in the system.

Periodically inspect all hoses, electrical cables and connections on your machine. Frayed or cracked hoses should be repaired or replaced to eliminate vacuum or solution pressure loss. The electrical cable must be well insulated and cable connector screw kept tight. If the cable insulation is broken or frayed, repair or replace immediately. Don't take chances with electrical fire or shock.

**Daily/Regular Maintenance**



**Before making any repairs or adjustments to the machine, disconnect the power cord from the electrical source.**

1. Empty unused cleaning solution from the solution tank.
2. Inspect and clean filter screen in solution tank.
3. Flush pumping system with 1 to 2 gallons of clean water.
4. After each use, rinse tank with fresh water. Periodically inspect the recovery tank and decontaminate if necessary, using a Hospital Grade Virucide or a 10-1 bleach to water solution. Waste water should be disposed of properly.

**Do not allow machine to freeze.**

SERVICE SCHEDULE	DAILY	WEEKLY	QUARTERLY
Check machine for cord damage	*		
Check recovery dome and gasket for damage and cleanliness	*		
Check hoses for wear, blockages, or damage	*		
Check handles, switches, and knobs for damage	*		
Run one gallon of water through solution system	*		
Clean out recovery tank and check float valve to make sure it moves freely	*		
Clean out solution tank and remove and clean vacuum intake screen	*		
Clean outside of all tanks and check for damage	*		
Run vac motor for at least one minute to allow motor to dry	*		
Store with dome off tank to allow the tank to dry	*		
Check all gaskets for wear and leakage		*	
Check pump pressure; observe spray pattern and check with gauge if necessary		*	
Check and clean solution screen		*	
Check cables for fraying		*	
Check overall performance of machine		*	
Check vac motor carbon brushes			*

**⚠ WARNING:**

Only qualified maintenance personnel are to perform the following repairs.

**Vacuum Motor Replacement**

1. Turn off all switches and unplug machine.
2. Remove hardware under front of machine to access component compartment.
3. Remove vacuum motor cover and disconnect motor wires.
4. Remove the vacuum motor.
5. Reverse process to install vacuum motor.

**Vacuum Motor Carbon Brushes Replacement**

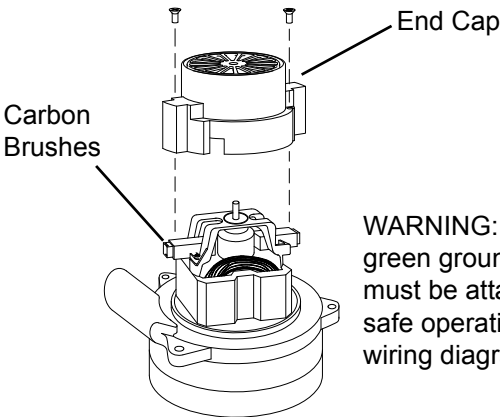

**WARNING:** The green ground wire must be attached for safe operation. See wiring diagram.

If armature commutator is grooved, extremely pitted or not concentric, the motor will need to be replaced or sent to a qualified service center.

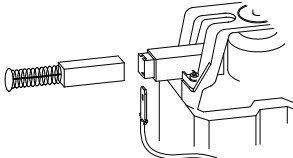

**Important:**

These brushes wear quicker as the length shortens due to increased heat. Spring inside brush housing will damage motor if brushes are allowed to wear away completely.

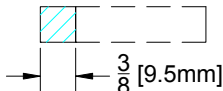

Periodically check the length of the carbon brushes. Replace both carbon brushes when either is less than 3/8" (9.5mm) long.

## Solution Pump Replacement

### **⚠ WARNING:**

Only qualified maintenance personnel are to perform the following repairs.

### Pump Replacement Kits 500 psi

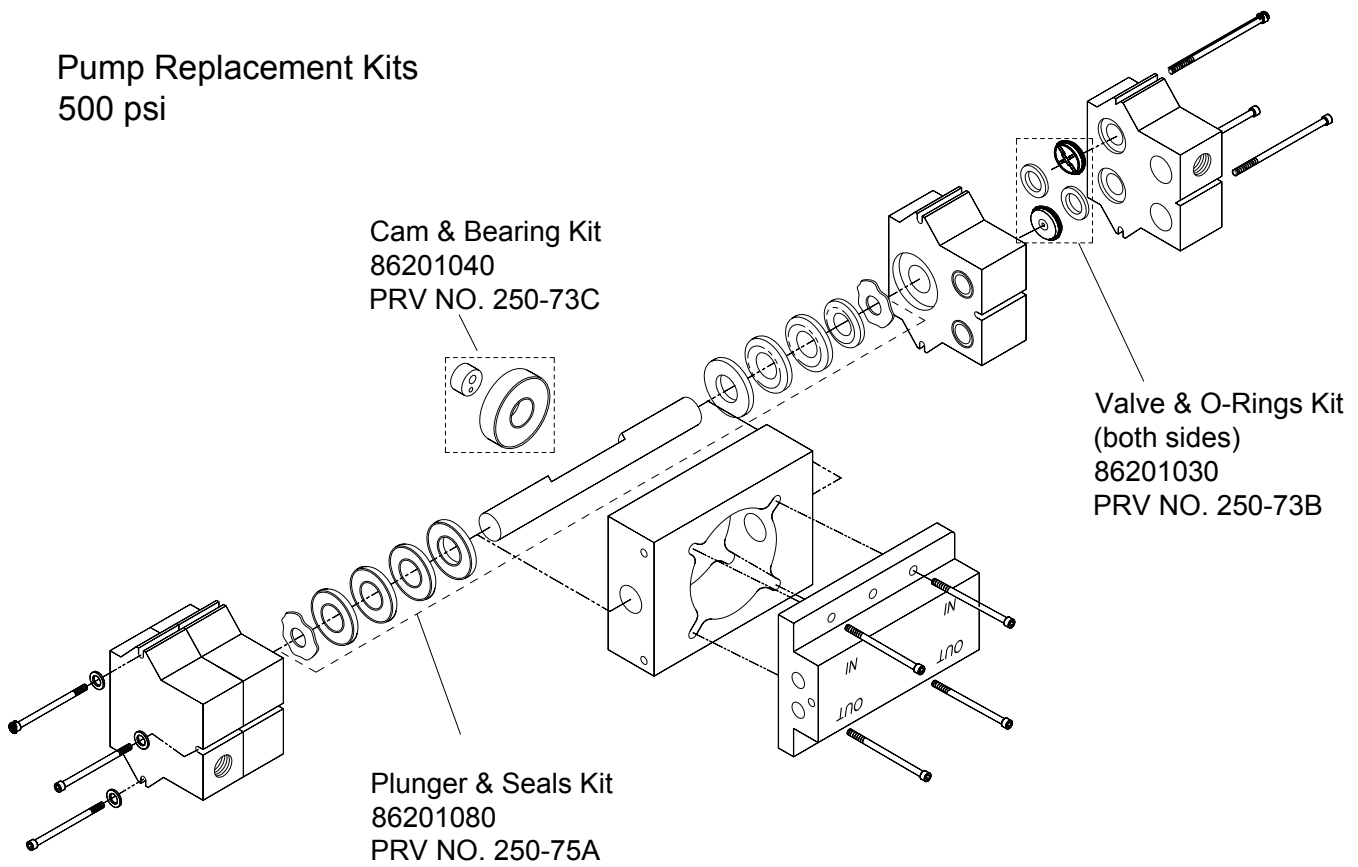

**! WARNING:**

Only qualified maintenance personnel are to perform the following repairs.

**Pressure Regulator**

For best results with the pressure regulator, we recommend that you clean and lubricate the piston and u-cup with Superlube lubricant monthly or when pressure drop seems excessive.

1. Turn unit off before lubricating.
2. Remove cap, spring and spring retainer plate.
3. With fingertips remove piston and u-cup.
4. Wipe piston and u-cup clean of any film or scale.
5. Lubricate the piston and u-cup with Superlube.
6. Reassemble regulator.
7. With pump ON, re-adjust pressure regulator for normal operation.

**Lubricate U-Cup with Superlube Monthly.**

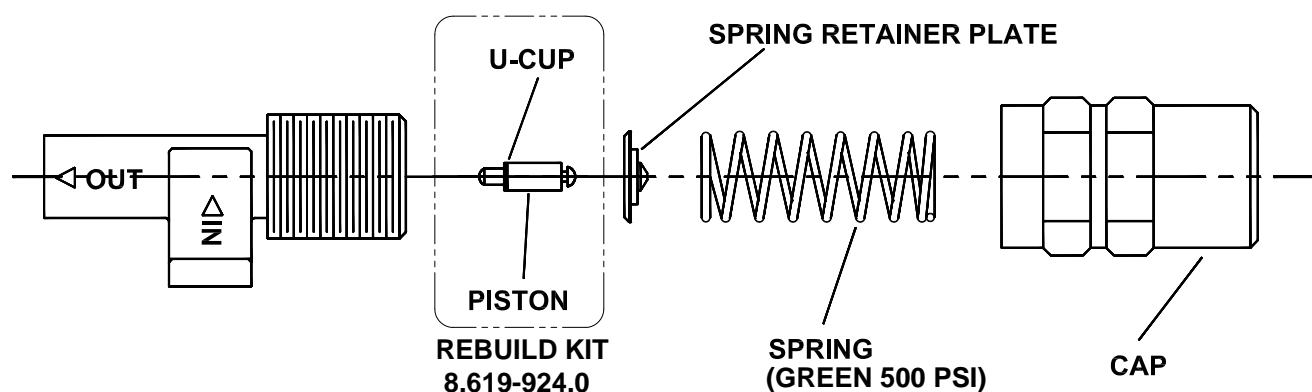

**Troubleshooting**

<b>PROBLEM</b>	<b>CAUSE</b>	<b>SOLUTION</b>
Loss of Power	Unit not plugged in	Connect unit to 3 prong grounded outlet.
	Dead electrical circuit	Check building circuit breaker or fuse box.
	Faulty power cord	Replace
Electrical shock	Receptacle not grounded	Contact an electrician to check building's wiring
	Internal wiring problem	Have a trained service technician check machine's wiring
Vac motor speed varies or doesn't run	Vacuum circuit breaker tripped	Reset Breaker
	Faulty vacuum motor	Replace
	Faulty switch	Replace
Loss of vacuum	Loose vacuum dome	Center and seal dome over tank
	Crack in dome of poor joint	Replace or repair using acrylic plastic cement only
	Lint or dirt clogging vacuum screen	With power off clean screen
	Loose cuffs on vacuum hose	Tighten cuffs turning counterclockwise
	Vac motor seals leaking	Replace
	Floor tool vac chamber clogged	Wash out with hose. Pick lint out with a wire
	Vacuum hose damaged	Replace
	Recovery tank full / Float ball stuck in the up position	Turn off power, drain recovery tank.
Pump runs no solution	Pump inlet screen plugged	Clean inlet screen
	Pump not primed	Prime pump with priming hose
	Internal or external solution line damaged and leaking	Replace
Pump runs, loss of pressure	Internal pump components wearing out	Replace, see pump kit components
	Check valves in pump head for particles or cuts in seals	Take piston from BPR and lubricate with Super-lube. If problem still exists change BPR kit
Pump will not run	Faulty switch	Replace
	Loose wiring	Repair or replace
Solution hose fitting hard to connect	Corrosion on fittings.	Clean with steel wool. Soak in acetic acid (white vinegar). Lubricate lightly with silicone base lubricant.
Carpet not getting clean	Severe soil conditions	Make several passes at right angles to each other. Use a pre-spray.
Carpet too wet	Over saturation	Adjust solution pressure to lower settings. Make several passes without spray
Carpet browning	Leaving carpet too wet	Check for loss of vac pressure
	Too much chemical	Check label for correct solution concentration
Solution not flowing properly	Solution hose connection	Check for positive connection
	Faulty pump	Repair or replace
	Faulty floor tool valve / Nozzle	Repair or replace
	Faulty pump switch	Repair

# PARTS

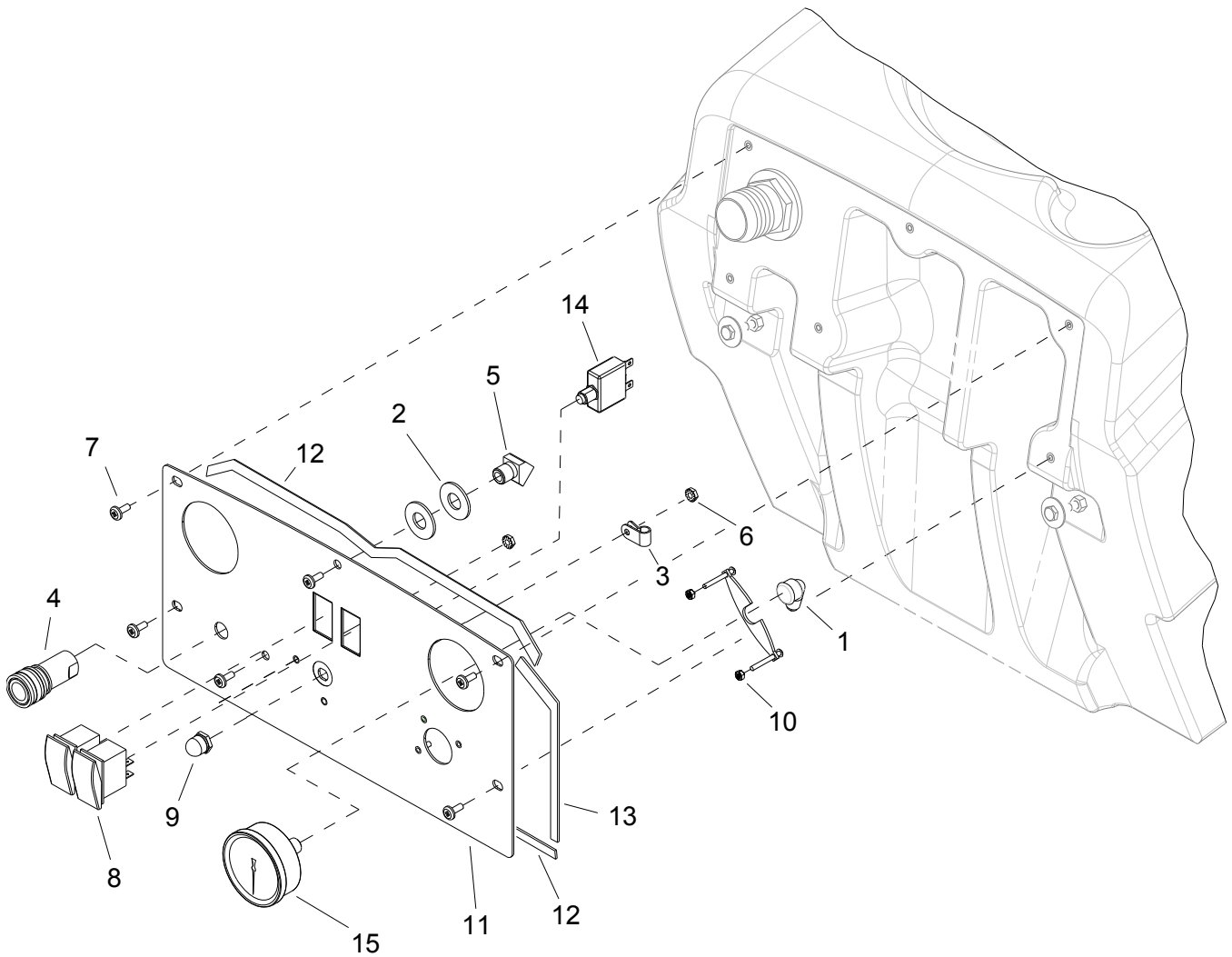

REF	PART NO.	PRV NO.	QTY	DESCRIPTION	SERIAL NO. FROM	NOTES
1	86180350	12-800035	1	ELL, 1/4FP X 1/4T BR		
2	86202230	390-09A	2	WASHER 9/16 S/S USS THICK		
3	86002370	20035	1	CLAMP, 7/16 DIA NYLON UL		
4	86002450	22015	1	COUPLER, 1/4 QD		
5	86197390	31021	1	ELBOW, 1/4NPT 45D STREET		
6	86005700	57104	2	NUT, 10-32 HEX W/STAR		
7	86276820	70740	6	SCR, 10-32 X 1/2 PTHMS BLK NP		
8	86007140	72130	2	SWITCH, SPST 2-POSITION ROCKER		
9	86008900	80845	1	BOOT, SEAL PUSH BUTTON 7/16"		
10	86005720	57106	2	NUT, 8-32 W/STAR WASHER PLTD		
11	86320850	-	1	PANEL, CONTROL, 500		
12	86313020	-	2	GASKET, .125 T X .25 W X 15.6"		
13	86313030	-	4	GASKET, .125 T X .25 W X 7.2"		
14	86318320	-	1	BREAKER, 13A, 250VAC, 32VDC		
15	86323310	-	1	GAUGE, 0-600 PSI		

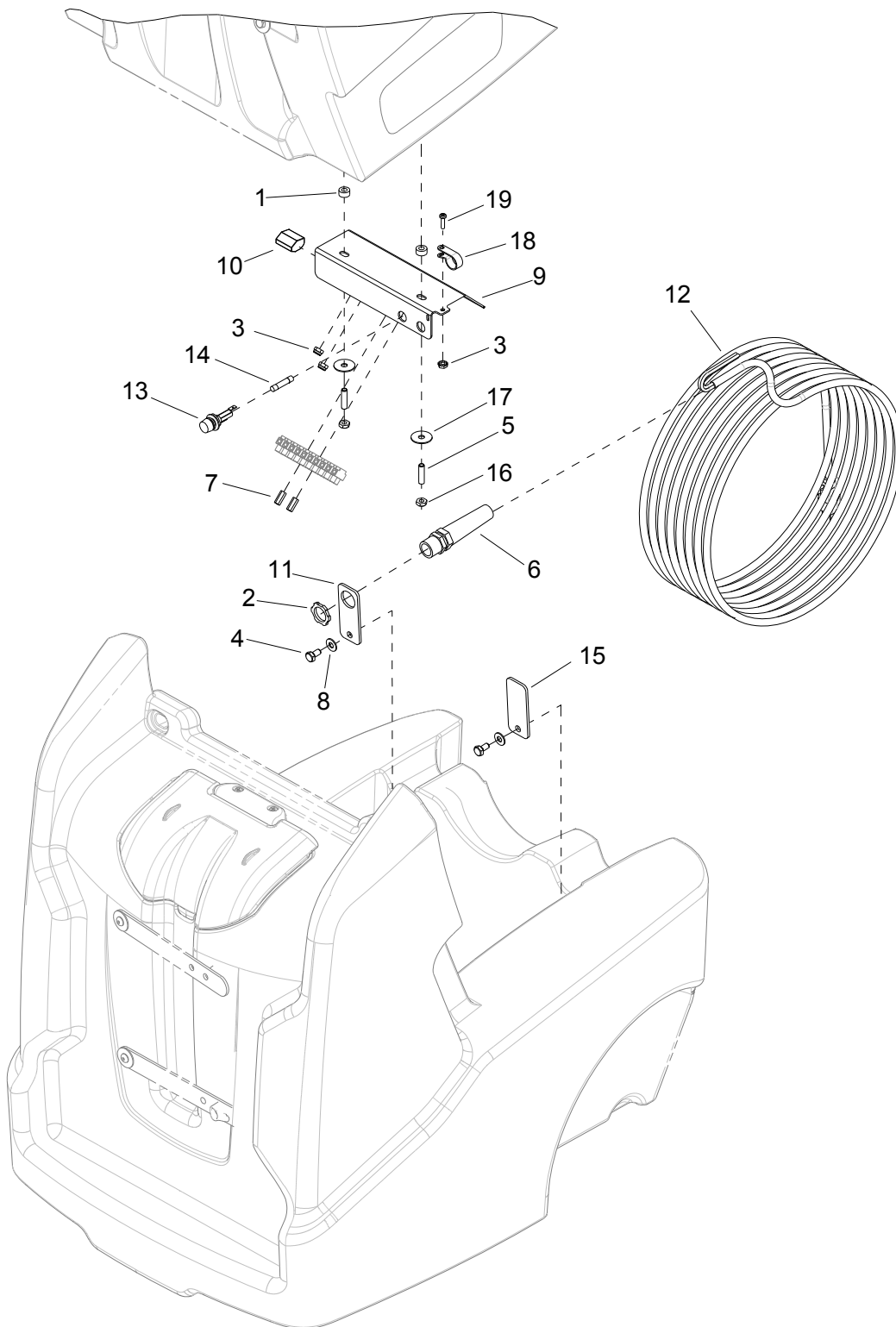

REF	PART NO.	PRV NO.	QTY	DESCRIPTION	SERIAL NO. FROM	NOTES
1	86201510	390-26	2	SPACER NYLON 1/4ID X 1/2 OD		
2	86005670	57040	1	NUT, 1/2 NPT CONDUIT		
3	86005700	57104	3	NUT, 10-32 W/STAR WASHER PLTD		
4	86273830	70020	2	SCR, 1/4-20 X 1/2 HHCS SS		
5	86006850	70393	2	SET SCR, 1/4-20 X 1.25L		
6	86256200	73200	1	STRAIN RELIEF, 1/2 NPT FLEX		
7	86255900	73538	2	STANDOFF, 6-32 X 5/8 HEX NYL		
8	86010630	87013	2	WASHER, 1/4 X 5/8 FLAT SS		
9	86316460	-	1	BRKT, ELECTRICAL		
10	86316540	-	1	CONNECTOR, 5 POS, PUSH WIRE		
11	86316700	-	1	BRKT, CORD STRAIN RELIEF		
12	86325300	-	1	CORD ASM, 14/3 X 40' GFCI BLK		
13	86319090	-	1	FUSE HOLDER, PANEL MNT		
14	86319110	-	1	FUSE, 1/4" X 1 1/4", 4A		
15	86317580	-	1	BRKT, CORD, BLANK		
16	86005810	57245	2	NUT, 1/4-20 NYLOCK		
17	86323330	-	2	WASHER, 1/4" ID X 1.0D FLAT BLK		
18	86198460	20008	1	CLAMP, 5/8 NYLON UL/CSA		
19	86006590	70088	1	SCREW, 10-32 X 1/2 PPHMS SS NP		

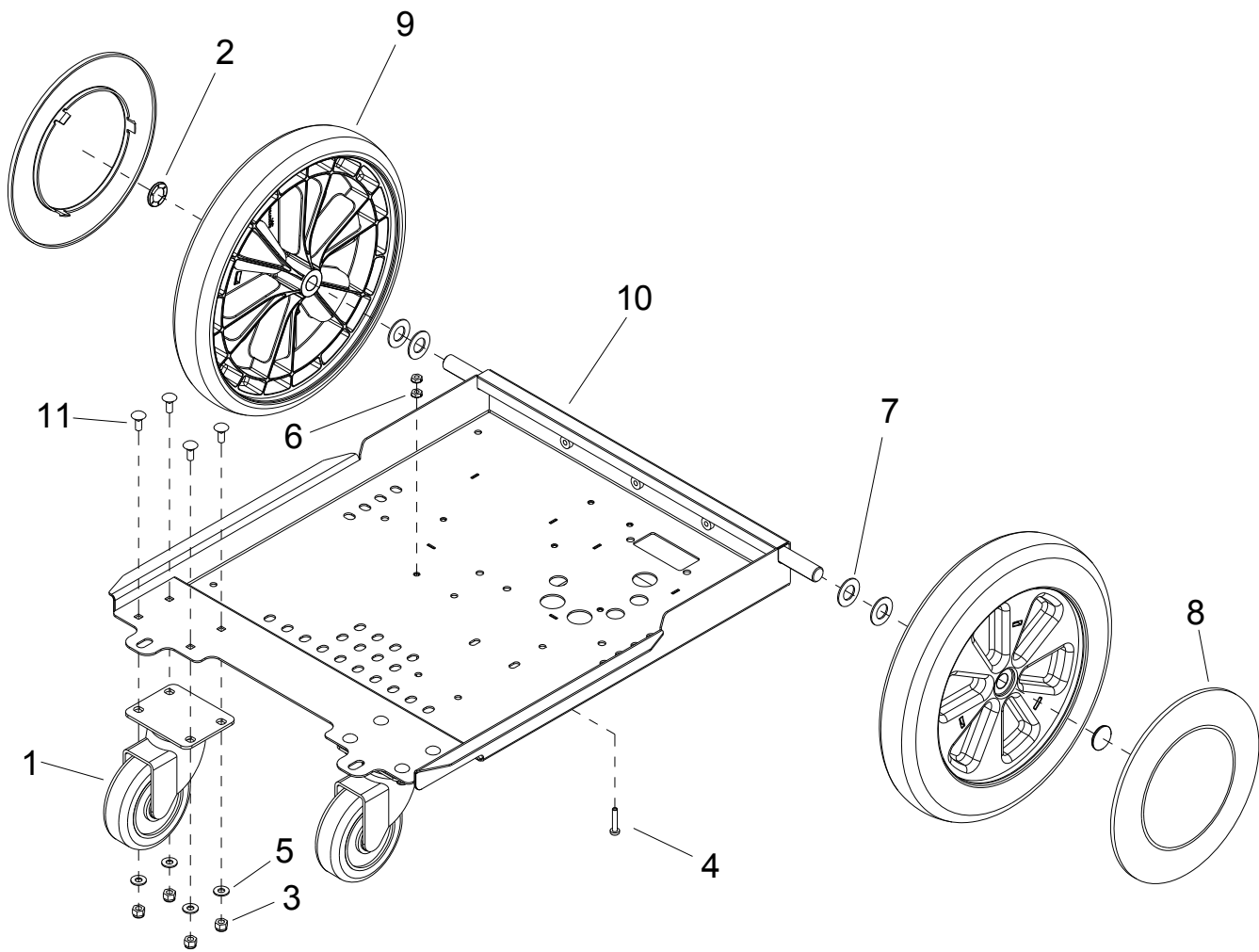

REF	PART NO.	PRV NO.	QTY	DESCRIPTION	SERIAL NO. FROM	NOTES
1A	86199430	040-03	2	CASTER, SWIVEL 4" 250# CPCTY		NON-ETL MODELS
1B	86327030	-	2	CASTER, SWIVEL 4" LOCKING		ETL MODEL
2	86001660	41236	2	HUBCAP, 5/8 SHAFT		
3	86005810	57245	8	NUT, 1/4-20 HEX NYLOCK SS		
4	86276080	70595	1	SCR, 10-32 X 1" PPHMS GRN		
5	86010630	87013	8	WASHER, 1/4 X 5/8 FLAT SS		
6	86005700	57104	2	NUT, 10-32 HEX W/STAR		
7	86010730	87088	4	WASHER, 5/8 X 1-3/16 FLAT SS		
8	86300070	-	2	HUBCAP, 9.75" WHEEL, BLACK		
9	86309790	-	2	WHEEL, 12" X 2.25"		
10	86322760	-	1	FRAME, 5/8" AXLE, SGL VAC		
11	86277500	70853	8	SCR, 1/4-20 X 5/8 CARR SS		

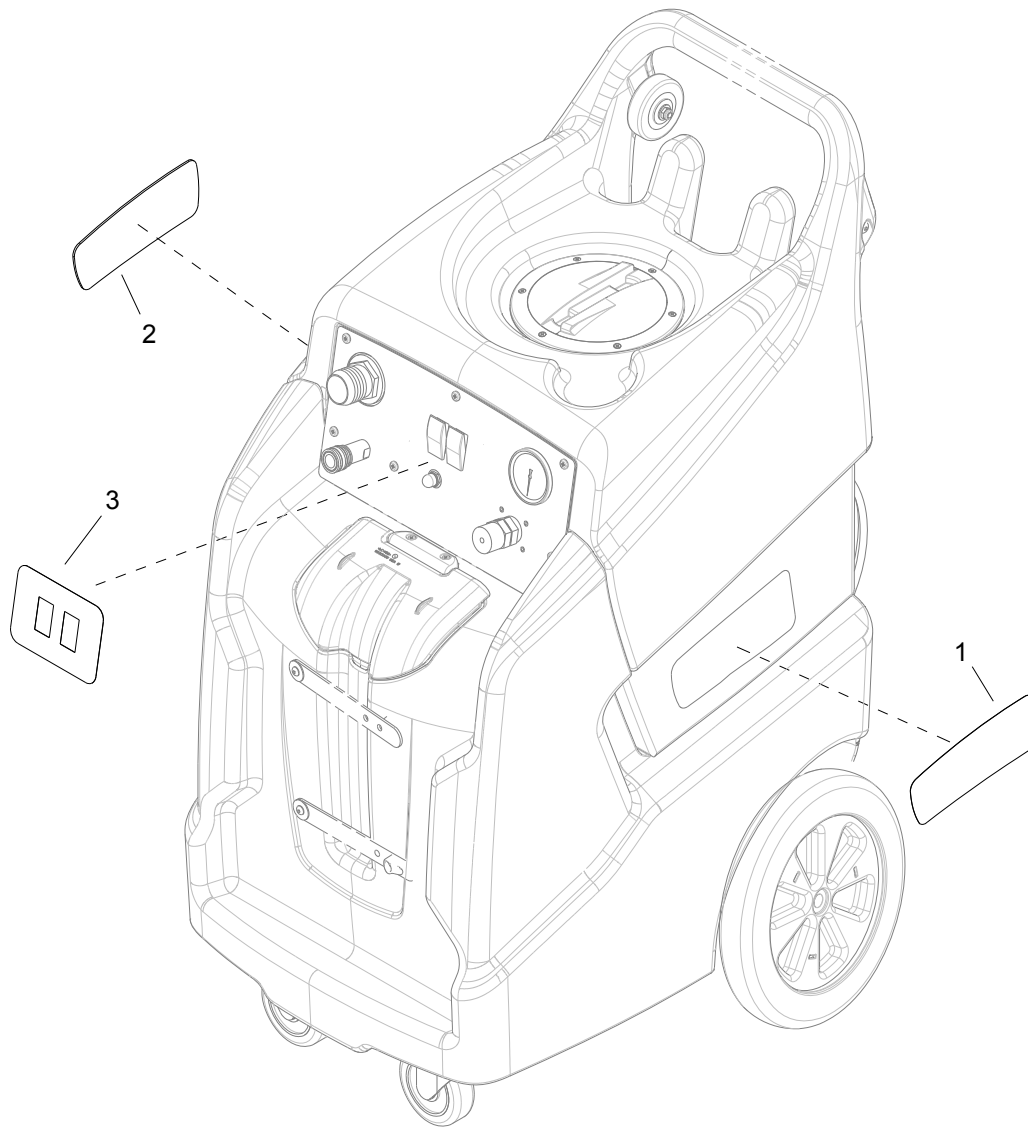

REF	PART NO.	PRV NO.	QTY	DESCRIPTION	SERIAL NO. FROM	NOTES
1	86342640	-	1	LABEL, RECOVERY, AKW , RH		
2	86343010	-	1	LABEL, RECOVERY, AKW , LH		
3	86342980	-	1	LABEL, CONSOLE, KARCHER		

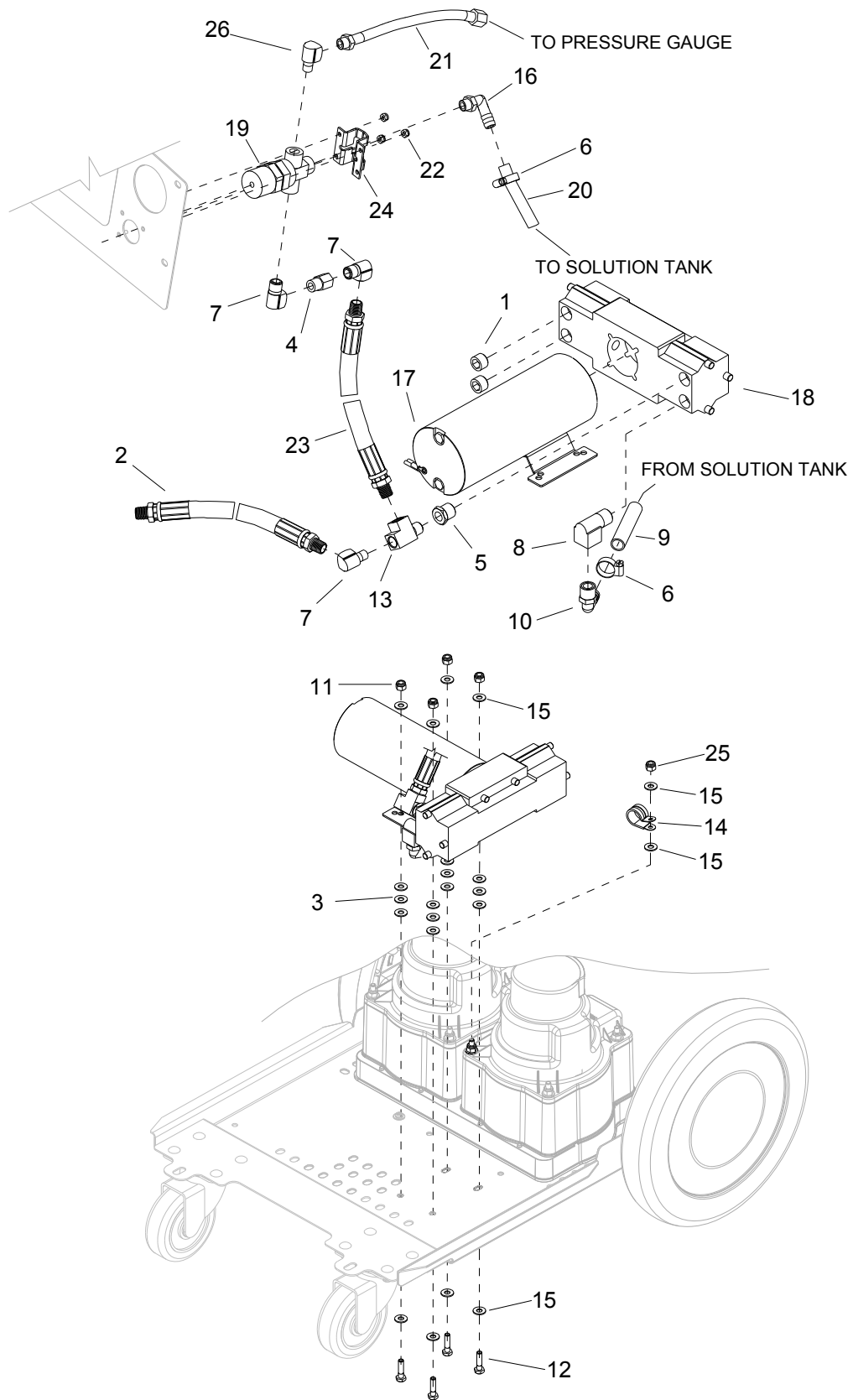

REF	PART NO.	PRV NO.	QTY	DESCRIPTION	SERIAL NO. FROM	NOTES
1	86190520	11-800224	2	PLUG, 3/8 SOCHD BR		
2	86200260	151-50C	1	HOSE,PULSE 47.0 1/4MPT X 1/4MPT		
3	86323300	-	12	WASHER, 1/4" RUBBER		
4	86197270	04008	1	ADPTR, 1/4MPT X 1/4FPT BR		
5	86197290	14076	1	BUSHING, 3/8 MPT X 1/4 FPT HEX		
6	86233150	20042	2	CLAMP, 3/8 WORM GEAR		
7	86197360	31016	2	ELBOW, 1/4 NPT STREET		
8	86197420	31026	1	ELBOW, 3/8NPT STREET		
9	86282320	39710	1	HOSE, 1/2ID WIRE BOUND X 26"		
10	86240500	40095	1	HOSEBARB, 3/8MPT X 3/8HOSE 90		
11	86005810	57245	4	NUT, 1/4-20 HEX NYLOCK SS		
12	86273810	70018	4	SCR, 1/4-20 X 1.00 HHCS SS		
13	86197760	78308	1	TEE, 1/4 STREET		
14	86233410	81270	1	CLAMP, 3/4 DIA CUSHION .406 DIA		
15	86010630	87013	10	WASHER, 1/4 X 5/8 FLAT SS		
16	86317550	-	1	HOSEBARB, 3/8 MPT X 1/2 90 BR		
17	86318980	-	1	MOTOR, M53, 120V, 3A W/ CAM		INCLUDES RECTIFIER
18	86318990	-	1	PUMP, SERIES 207V		
19	86321290	-	1	BPR, 500PSI		
20	86321470	-	1	HOSE, 3/8ID WIRE BOUND X 26"		
21	86317590	-	1	HOSE, 10" 1/4JIC X 1/8MPT SS		
22	86270850	57026	3	NUT, 8-32 HEX NYLOCK		
23	86323550	-	1	HOSE, 47" HP 1/4-MPT X 1/4-MPT		
24	86321280	-	1	BRKT, D/P BPR		
25	86005710	57105	1	NUT, 1/4-20 HEX W/STAR WASHER		
26	86321660	-	1	ELBOW, 1/4 MPT X 1/8 FPT		



REF	PART NO.	PRV NO.	QTY	DESCRIPTION	SERIAL NO. FROM	NOTES
1	86161460	15-808123	1	DUMP VALVE, 1 1/2		
2	86002620	260-64A	1	ACCESS, COVER CLEAR 6" W/RIM		
3	86197820	31002	1	ELBOW, 1.5 FPT X FS PVC		
4	86004000	35255	1	GASKET, TANK LID		
5	86197040	57264	2	NUT, 5/16-18 HEX ACORN PLTD		
6	86273740	70010	2	SCR, 1/4-20 X 1.50 HHCS SS		
7	86273750	70011	4	SCR, 1/4-20 X 5/8 HHCS SS		
8	86275800	70546	6	SCR, 8 X 3/4 PFHT/S BLK ZINC		
9	86010630	87013	4	WASHER, 1/4 X 5/8 FLAT SS		
10	86010670	87029	6	WASHER, 5/16 X 3/4 SS		
11	86323330	-	2	WASHER, 1/4 ID X 1.0 OD FLAT BLK		
12	86011020	89202	2	WHEEL, 3" DIA. CUSHION RUBBER		
13	86001350	140390	2	BUSHING, SPANNER .435 X 1.10		
14	86227120	04095	1	ADAPTER, FLOAT 30 DEG		
15	86342850	-	1	TANK, REC, 13G TRIM AKW		
16	8619-9840	090-12A	1	SCRN, FLOAT, CAGE ASSY		
17	86316710	-	2	BRKT, CORD, MOUNT		
18	86317230	-	1	HOSEBARB, 1.5MPT X 1.5 W/FLNG		
19	86317720	-	2	SCR, 5/16-18 X 2.50 BSHCS SS		
20	86321720	-	1	PIPE ASM, 1.5", VACUUM		
21	86002380	20046	1	CLAMP, 2.25" WORM GEAR		

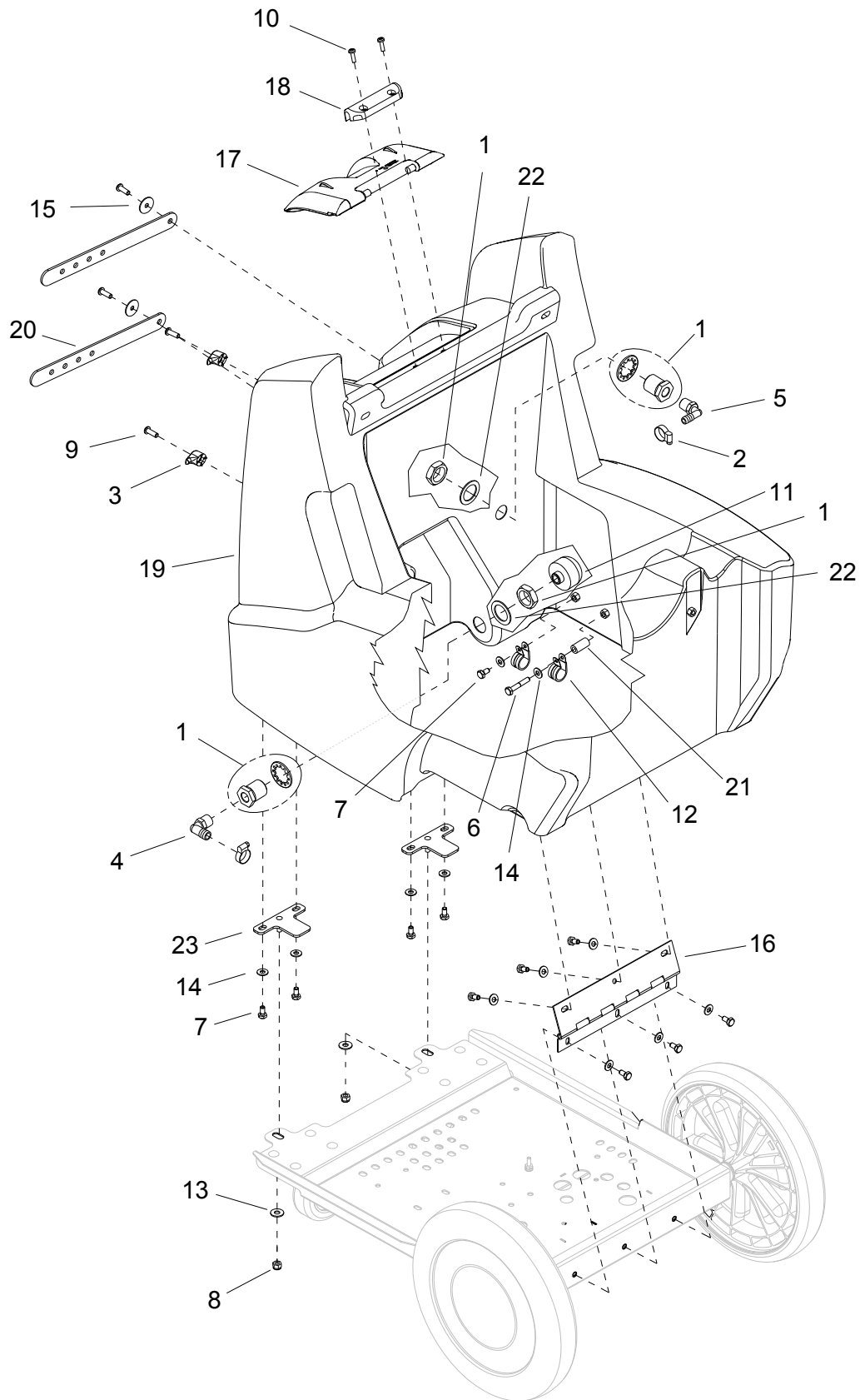

REF	PART NO.	PRV NO.	QTY	DESCRIPTION	SERIAL NO. FROM	NOTES
1	86173640	11-800437	2	ADPT,3/8 BLKHD		COMPLETE
2	86233150	20042	2	CLAMP, 3/8 WORM GEAR		
3	86238460	36259	2	HOOK, STRAP		
4	86197940	40027	1	HOSEBARB, 3/8 MPT X 1/2 HOSE 90°		
5	86001550	40043	1	HOSEBARB, 3/8 MPT X 3/8 HOSE 90°		
6	86273740	70010	1	SCR, 1/4-20 X 1.50 HHCS SS		
7	86273830	70020	11	SCR, 1/4-20 X 1/2 HHCS SS		
8	86005810	57245	2	NUT, 1/4-20 HEX NYLOCK SS		
9	86324210	-	4	SCR, 1/4-20 X 5/8 BHCS BLK		
10	86276160	70604	2	SCR, 10-32 X 5/8 PPHMS BLK		
11	86007970	73864	1	STRAINER, 3/8 IN. NPT 60 MESH		
12	86233410	81270	2	CLAMP, 3/4 DIA CUSHION .406 DIA		
13	86010670	87029	2	WASHER, 5/16 X 3/4 SS		
14	86010630	87013	12	WASHER 1/4 ID X 5/8 OD SS		
15	86323330	-	2	WASHER, 1/4 ID X 1.0 OD FLAT BLK		
16	86311990	-	1	HINGE, 9.5" LG X .074 THK		
17	86312000	-	1	LID, SOLUTION, COVER		
18	86312010	-	1	LID, SOLUTION, HINGE BRKT		
19	86321370	-	1	TANK, SOL, TRIM		
20	86297620	-	2	STRAP, HAND TOOL		
21	86317560	-	1	SPACER, .50 ODX .28 ID X 1.0L		
22	86318790	-	2	WASHER, 1.032ID X 1.5OD X .062THK		
23	86324030	-	2	PLATE, MOUNTING, SOLUTION		



REF	PART NO.	PRV NO.	QTY	DESCRIPTION	SERIAL NO. FROM	NOTES
1	86277840	00-000167	4	SCR, 1/4-20 X 6.5 HHCS PLT		
2	86005810	57245	4	NUT, 1/4-20 HEX NYLOCK SS		
3	86274090	70092	2	SCR, 10-32 X 1.5 PPHMS		
4	86002390	20063	2	CLAMP, 1.75 WORM GEAR X .312		
5	86010630	87013	8	WASHER, 1/4 X 5/8 FLAT SS		
6	86278990	87017	4	WASHER, #8 X 3/8 FLAT		
7	86312340	-	1	MANIFOLD, VACUUM		
8	86313810	-	1	GASKET, VAC MANIFOLD, SINGLE		
9	86317630	-	4	SCR, #8 X 3/4" PPHSMS TYPE AB		
10	86239910	39306	1	HOSE, VAC, 1.5 ID X 17"L		
11	86318770	-	1	VAC ASM, 3-STAGE, 120V		
-	86135320	140687	-	SP BRUSHES SET (120V VAC)		
12	86312080	-	1	COVER, VAC MOTOR		
13	86312120	-	1	BASE, VAC MOTOR, 3-STAGE		
-	86319030	-	-	VAC HOUSING, 3 STAGE		INCLUDES 12, 13

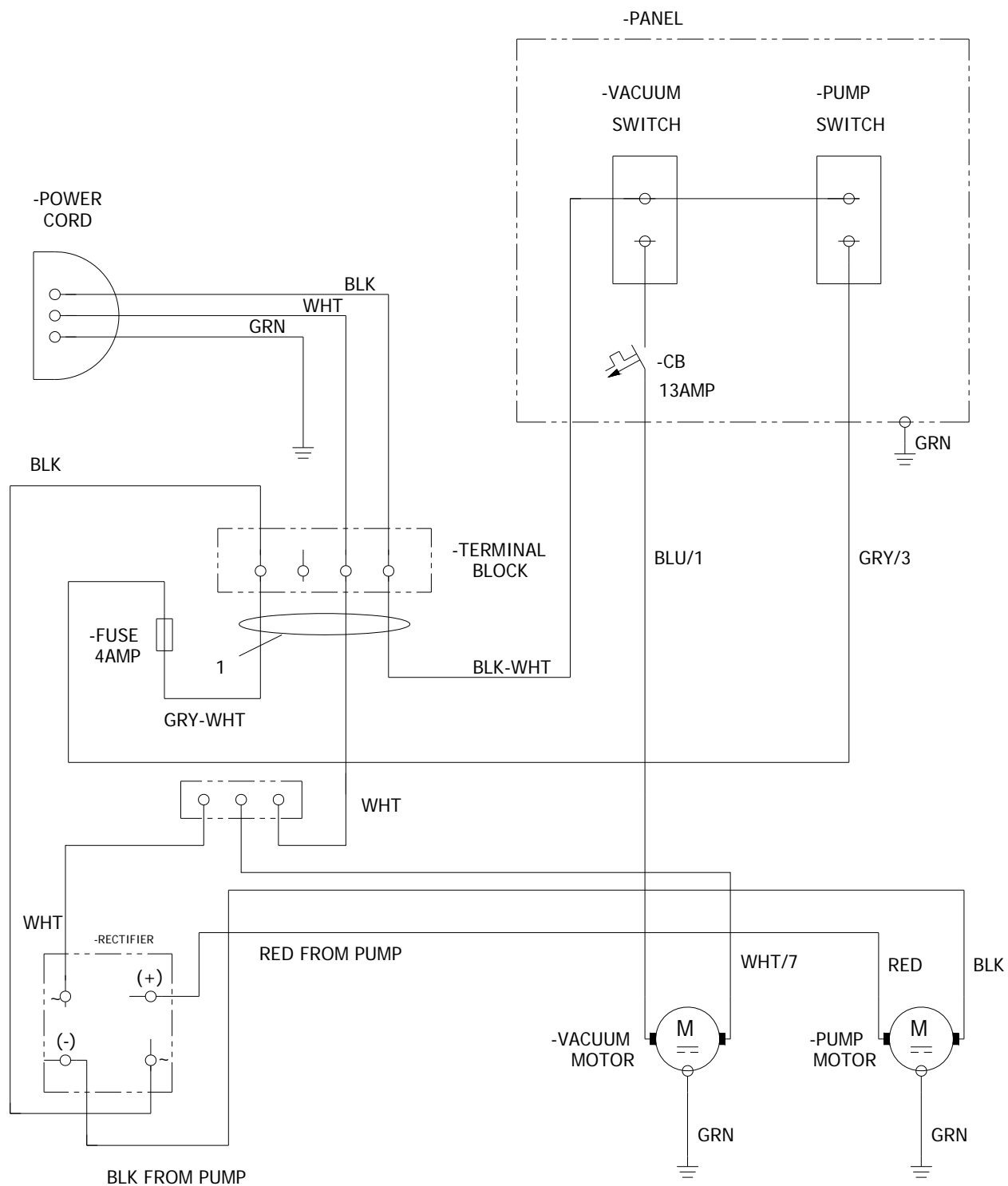

REF	PART NO.	PRV NO.	QTY	DESCRIPTION	SERIAL NO. FROM	NOTES
1	98407900	-	1	HARNESS KIT, SINGLE CORD		

## Suggested Spare Parts

---

<b>PART NO.</b>	<b>PRV NO.</b>	<b>DESCRIPTION</b>	<b>SERIAL NO. FROM</b>	<b>NOTES</b>
86199240	250-33A	BPR REPAIR KIT PUMPTEC		
86135320	140687	BRUSH SET, 120V VAC		
86199430	040-03	CASTER SWIVEL 4" 250# CAPACITY		
86002620	260-64A	ACCESS COVER CLEAR 6" W/RIM		
86319110	-	FUSE, 1/4" X 1-1/4", 4A		
86318770	-	VAC ASSY 3-STG, 120V		
86007140	72130	SWITCH, SPST 2-POSITION ROCKER		
86309790	-	WHEEL, 12" X 2.25"		
86001660	41236	HUBCAP, 5/8" SHAFT		
86007970	73864	STRAINER 3/8" NPT 60 MESH		
86201040	250-73C	CAM & BEARING KIT		
86201080	250-75A	PLUNGER & SEALS KIT		
86201030	250-73B	VALVE & O RINGS KIT		
86324290	-	PRIMING HOSE		
86006350	67029	RECTIFIER, BRIDGE		

REF. NO.	MODEL: SERIAL #
1	N/A