

Sprite™ 16

Sprite™ 16 Pro

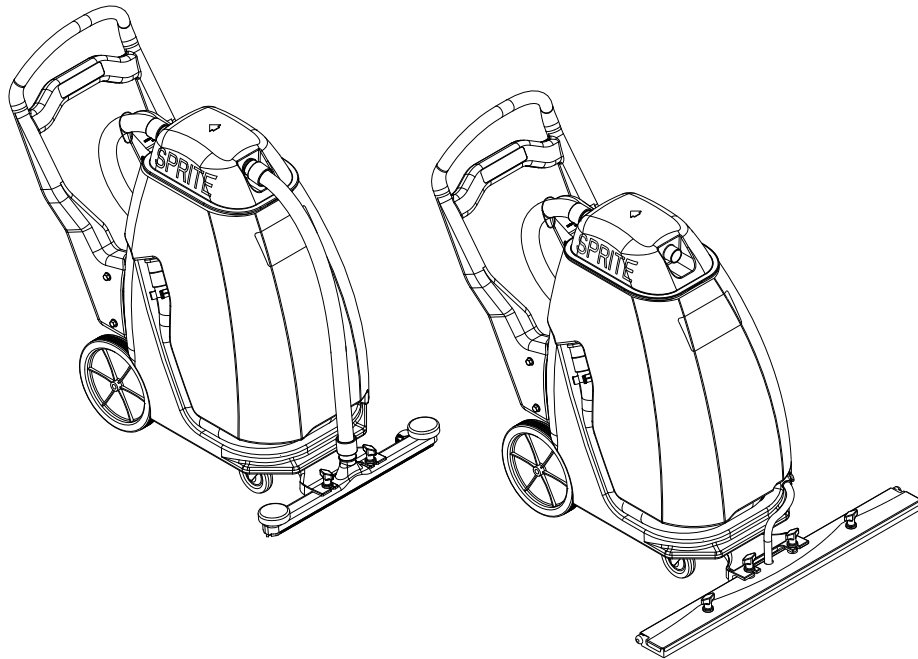

PARTS LIST

Advance MODELS 56381746, 56381727



Advance

11/10 revised 12/11 FORM NO. 56042582

<u>DESCRIPTION</u>	<u>PAGE</u>
Handle & Chassis System	2-3
Vacuum Motor System	4-5
Tank System	6-7
Squeegee Lift System	8-9
Applicator Lift System - Pro	10-11
Ladder Diagram	12
Options & Accessories	13

WHEN ORDERING PARTS

- * Use the part numbers from the "Ref. No." columns in this parts list.
- * Specify the model and serial number of the machine.
- * Use the space below to record the model and serial number for future reference.

Model _____ Serial No. _____

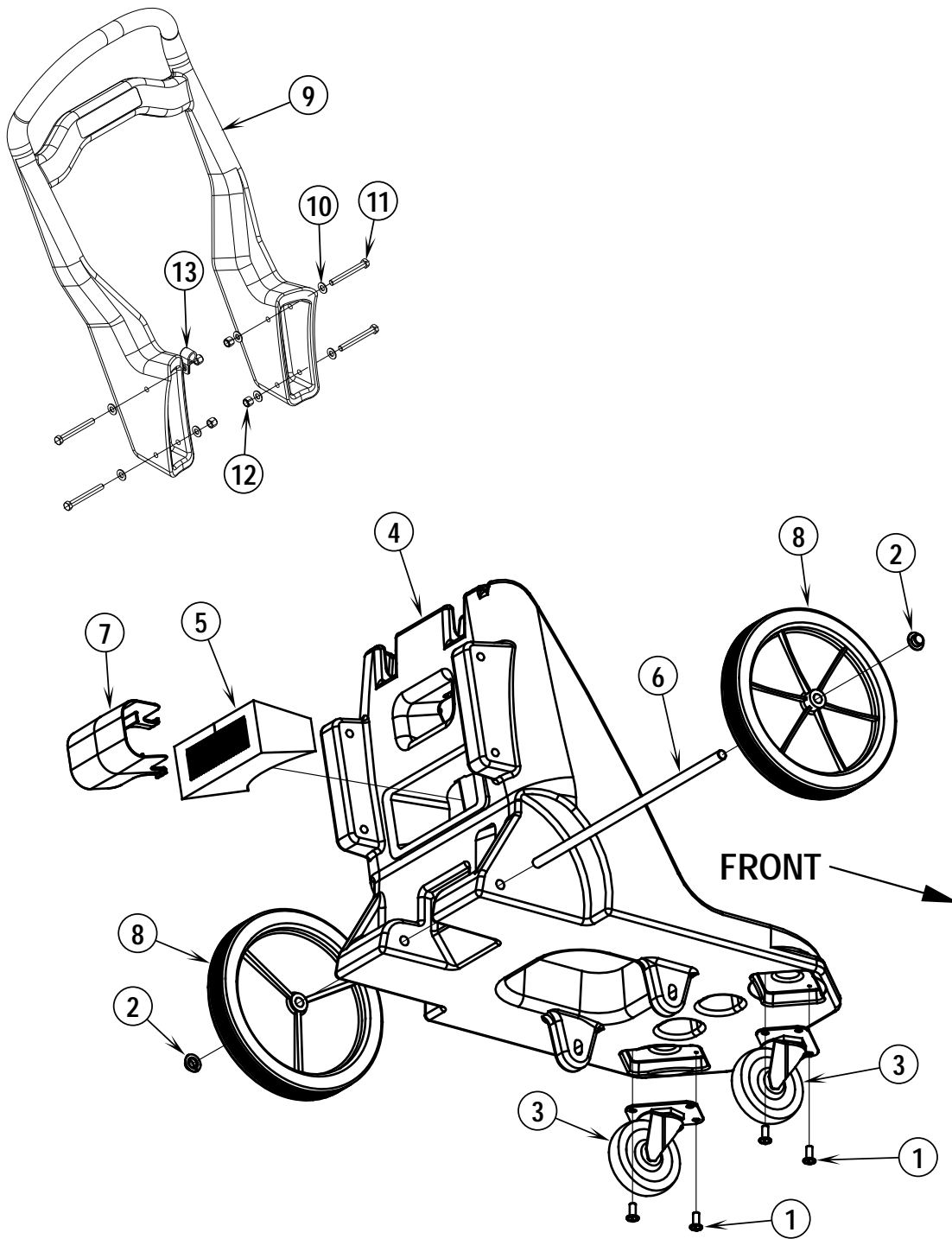

Item	Ref. No.	Qty	Description
1	56002155	4	Scr, Hex Hd 1/4-20 x .75
2	56009097	2	Nut, Push Cap 1/2
3	56209076	2	Caster, 4"
4	56209077	1	Chassis
5	56209087	1	Silencer
6	56209094	1	Axle, Wheel
7	56209177	1	Deflector, Exhaust
8	56249505	2	Wheel
9	56209079	1	Handle
10	56002910	8	Wsh, Fit SAE SS 3/8
11	56002284	4	Scr, Hex Hd 3/8-16 x 3.25
12	56002769	4	Nut, Hex Nyl Loc 3/8-16
13	56419120	1	Clamp-Hose Support

VACUUM MOTOR SYSTEM

10-11

4

Sprite™ 16, Sprite™ 16 Pro

11-6

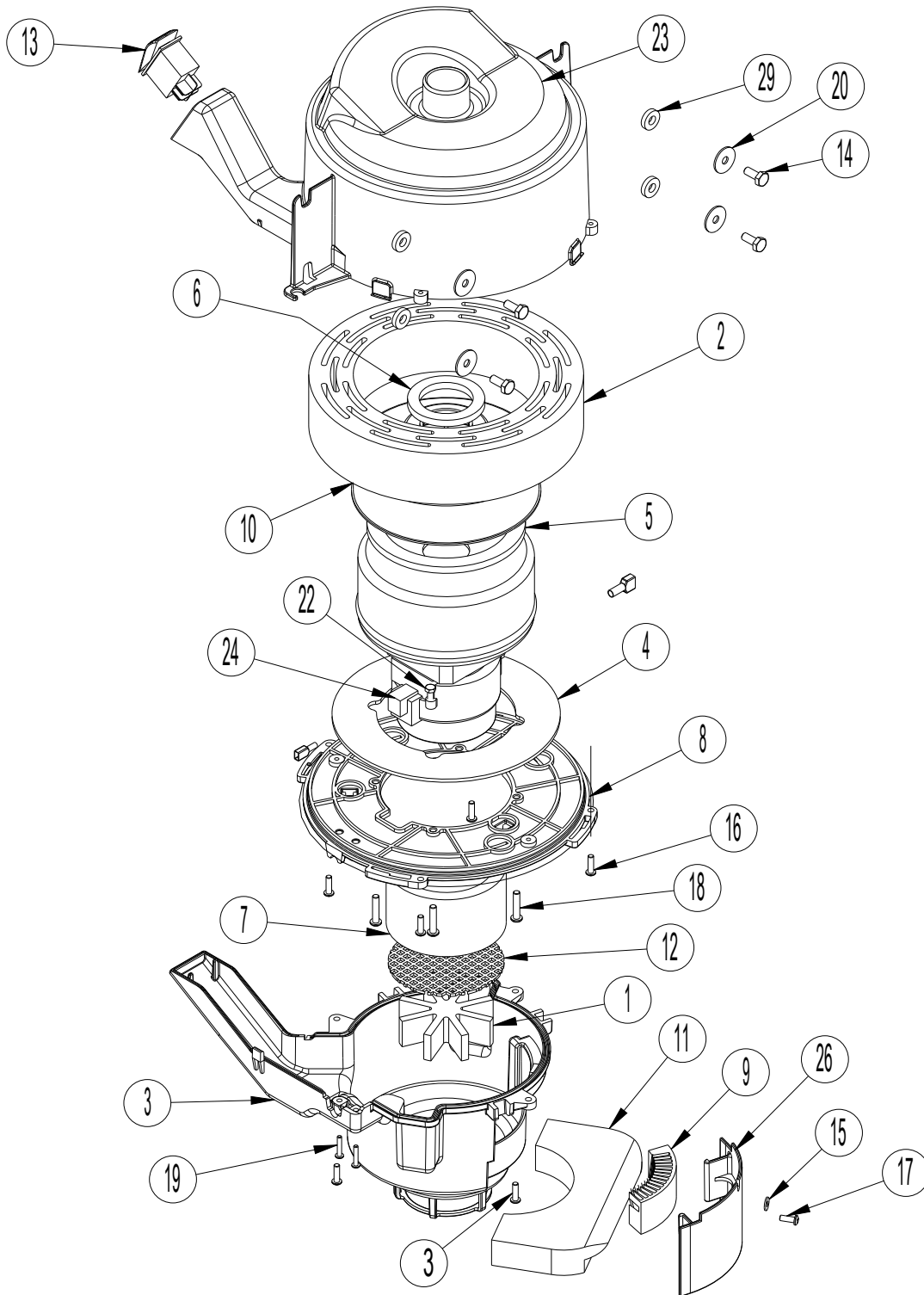

10-11

VACUUM MOTOR SYSTEM

11-6

Sprite™ 16, Sprite™ 16 Pro**5**

Item	Ref. No.	Qty	Description
1	56209080	1	Filter, Cool Air Intake
2	56209086	1	Dampener, Acoustical
3	56209099	1	Cover, Lower Motor
4	56209116	1	Gasket, Motor
5	56209127	1	Gasket, Upper
6	56209129	1	Gasket, Motor Cover
7	56209172	1	Seal, Motor Lower
8	56209192	1	Base Assy, Motor
9	56209195	1	Dampener, Cooling Air Acoustical
10	56209210	1	Plate, Stiffener
11	56209252	1	Deflector
12	56209253	1	Screen
13	56209321	1	Switch, Rocker Dpst
14	56001836	4	Scr, Hex 1/4-20 X .62
15	56002140	1	Wsh, Fit Sae #8
16	56002738	7	Scr, Pan Phil Plastite 8-16 X .62
17	56003093	1	Scr, Pan Phil Plastite 8-16 X .50
18	56003112	4	Scr, Pan Phil Plastite 10-14 X 1.00
19	56003331	2	Scr, Pan Phil Ss 6-32 X .75
20	56009002	4	Wsh, Fit .266 X .906 X .060
22	56009012	1	Scr, Hex Thd Form 10-24 X .38
23	56209097	1	Cover, Upper Motor
24	56209142	1	Vac Motor Assy
26	56209251	1	Guard
29	56706095	4	Washer, Rubber .31x.69x.156
[]	56265112	1	Cord Set 50ft 14/3 Yel
[]	56380313	1	Pigtail Cord Sprite
*	56209628	1	Power Module 120V STD

[] = Not Shown

* = Optional, Not Included

TANK SYSTEM

10-11

6

Sprite™ 16, Sprite™ 16 Pro

11-6

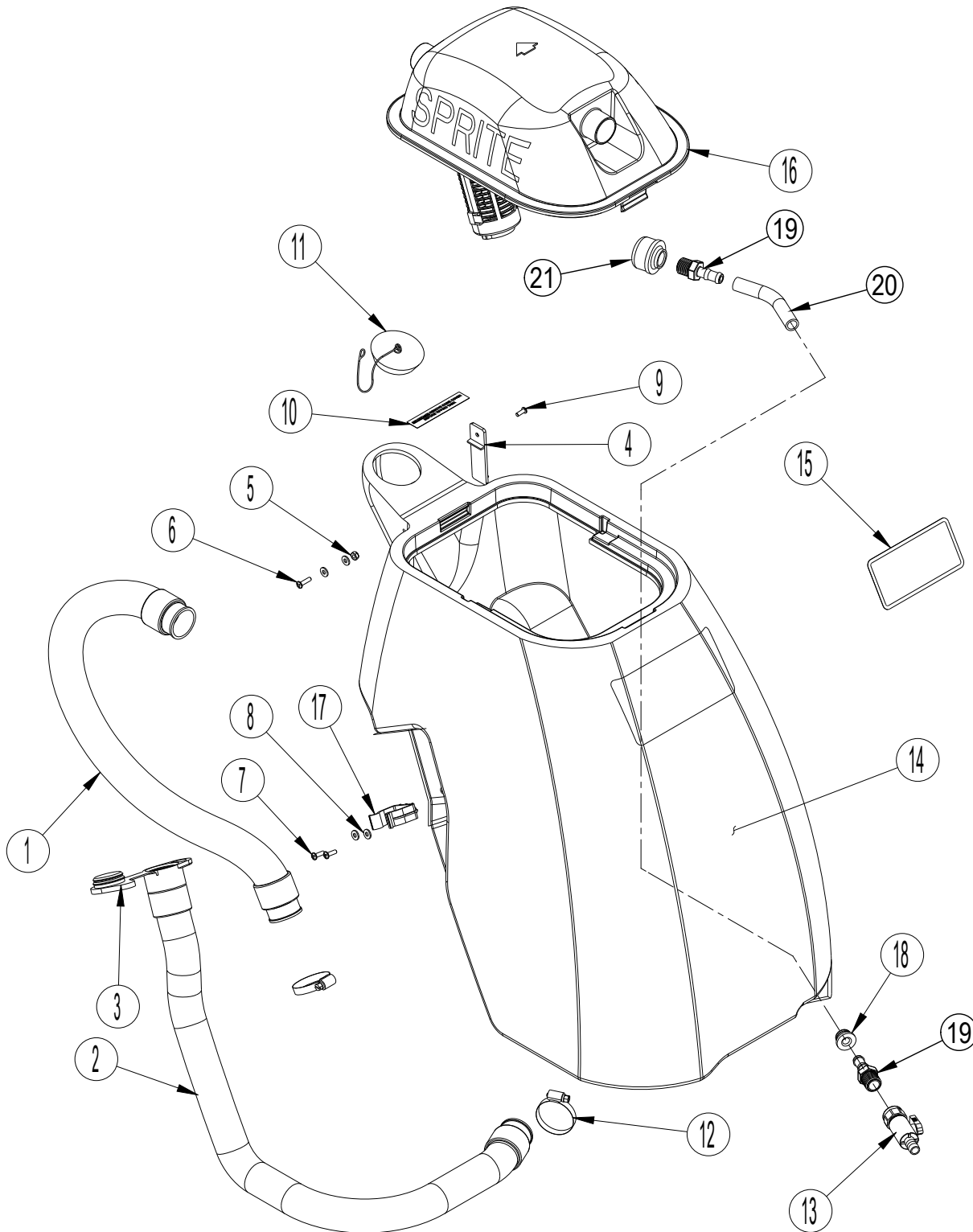

10-11	TANK SYSTEM		
11-6	Sprite™ 16, Sprite™ 16 Pro		7

Item	Ref. No.	Qty	Description
1	56209108	1	Hose Assy
2	56209109	1	Hose Assy
3	56209176	1	Plug, Hose
4	56412309	1	Water Level Guage NOTE 1
5	56002849	1	Nut, Hex Nyl Loc-Thin Ss 10-24
6	56002894	1	Scr, Pan Phil Ss 10-24 X .75
7	56002896	2	Scr, Pan Phil Ss 10-24 X .62
8	56002916	4	Wsh-Fit Sae Ss #10
9	56003093	1	Scr, Pan Phil Plastite 8-16 X .50 NOTE 1
10	56016248	1	Decal-Important
11	56209114	1	Stopper, Rubber, 2.5 Inch
12	56329145	2	Clamp- Hose Sae #24
13	56381967	1	Ball Valve Two-Way NOTE 1
14	56381726	1	Recovery Tank 16 Gal Pro NOTE 1
	56380302	1	Recovery Tank 16 Gal NOTE 2
15	56381730	1	Decal-Sprite 16 Pro NOTE 1
	56016198	1	Decal-Sprite 16 NOTE 2
16	56381732	1	Cover Ptd Bl/Gray Tint Assy
17	56407361	1	Clamp, Plastic
18	9095286000	1	Gasket NOTE 1
19	56381969	2	Hose Barb 1/2 NOTE 1
20	56381970	1	Hose PVC .50X4.50 NOTE 1
21	56381968	1	Strainer 1/2 FNPT NOTE 1

NOTE 1: These parts are only used on the Sprite 16 Pro
NOTE 2: These parts are only used on the standard Sprite 16

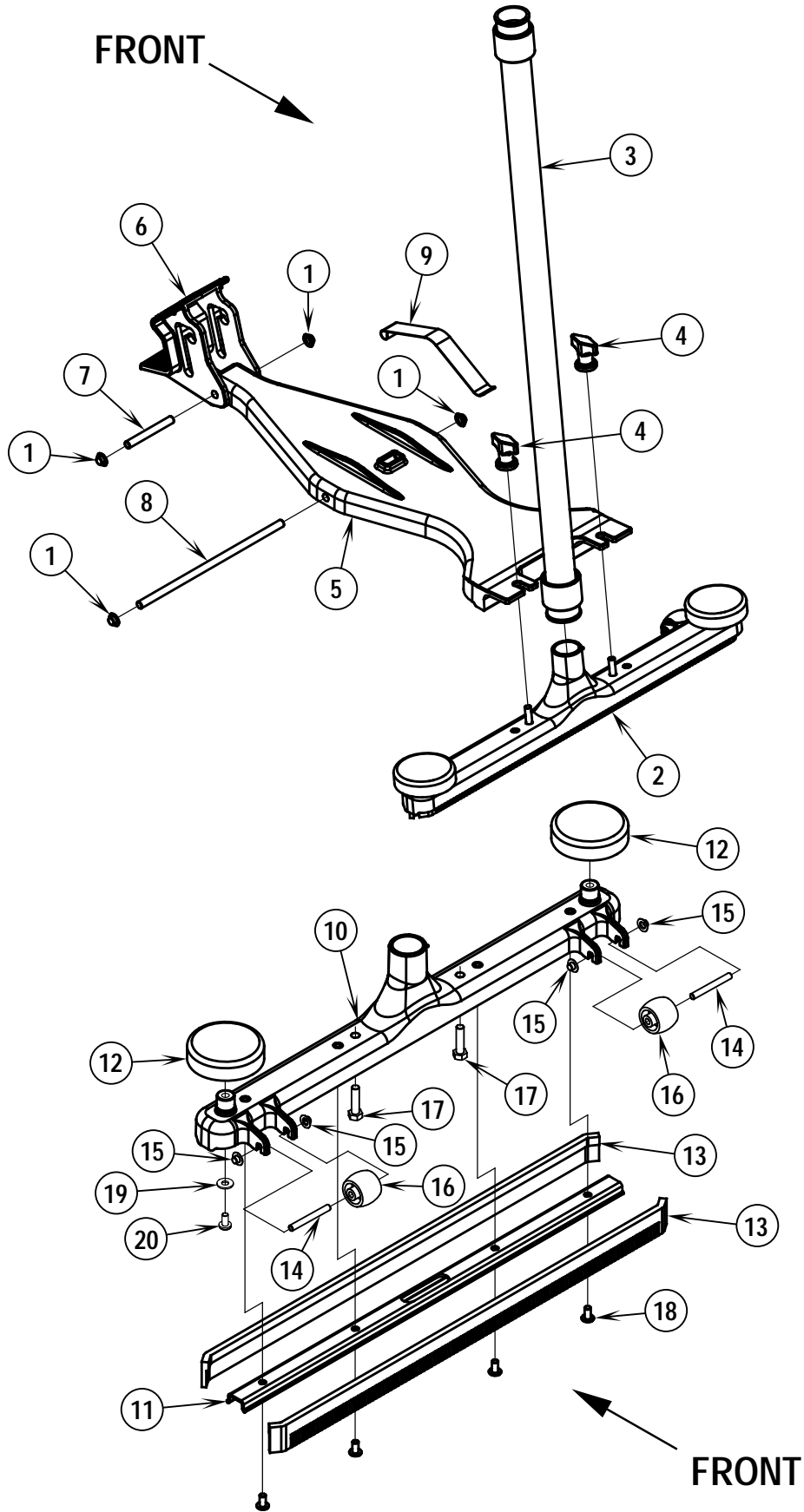

10-11

SQUEEGEE LIFT SYSTEM

11-12

Sprite™ 16, Sprite™ 16 Pro**9**

Item	Ref. No.	Qty	Description
1	56009123	4	Nut, Push Cap 3/8
2	56209088	1	24" Squeegee Assy STD (#10-20)
*	56209089	1	30" Squeegee Assy OPT (#10-20)
3	56209109	1	Hose Ass'y 1.50
4	56209154	2	Nut, Thumb
5	56209158	1	Squeegee Lift
6	56209159	1	Pedal
7	56209160	1	Axle, Pedal
8	56209161	1	Axle, Base
9	56209162	1	Spring
10	56209155	1	Housing, Squeegee 24"
[*]	56209156	1	Housing, Squeegee 30"
11	56209130	1	Retainer, Squeegee 24"
[*]	56209131	1	Retainer, Squeegee 30"
12	56209157	2	Bumper, Side Roller
13	56105533	2	Blade 24"
[]	56105509	2	Blade 30"
14	56209150	2	Axle
15	56009132	4	Nut, Push Cap 1/4
16	56329554	2	Roller
17	56002884	2	Scr, Hex Hd SS 5/16-18X1.25
18	56003119	4	Scr, Pan Phil SS 1/4-20X.50
19#	56002916	2	Wsh Flt SAE SS 10
20	56009237	2	Scr, Pan Phil SS Type 8 10-16 x .38

[] = Not Shown

* = Optional, Not Included

= Revised or new since last update

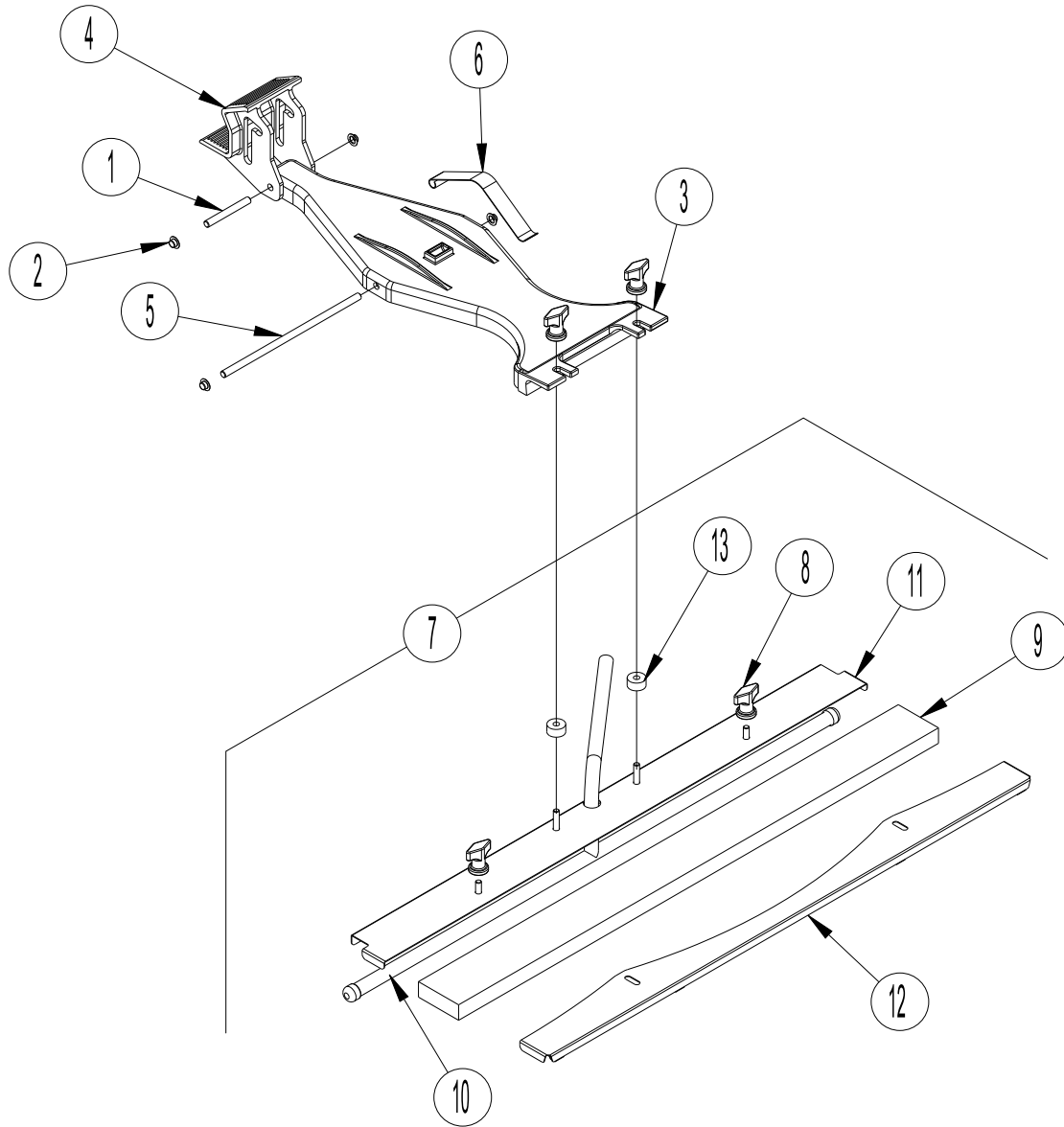

Item	Ref. No.	Qty	Description
1	56209160	1	Axle, Pedal
2	56009123	4	Nut, Push Cap 3/8
3	56209158	1	Squeegee Lift
4	56209159	1	Pedal
5	56209160	1	Axle, Base
6	56209162	1	Spring
7	56381729	1	Applicator Stripper Assy (8-13)
8	56209154	4	Nut, Thumb
9	56380303	1	Pad Stripper
10	56380304	1	Tube Assy-Applicator 36 In
11	56380305	1	Stripper Back Plate
12	56380306	1	Stripper Front Plate
13	56380309	2	Spacer Tool Mount

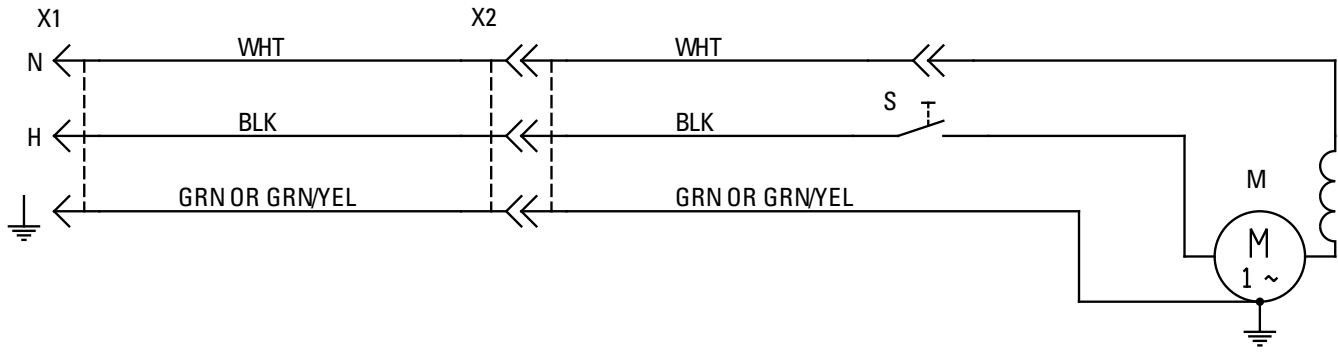

Item	Ref. No.	Qty	Description
S	56262551	1	Switch, Main
M	56209142	1	Motor, Vacuum

Ref. No.	Qty	Description
56209224	1	Standard Tool Kit
56204213	1	Vacuum Hose 1.50" Assembly
56100376	1	11" Crevice Tool
56100375	1	5" Upholstery Tool
56100377	1	3" Round Dusting Brush
56209233	1	14" ABS Squeegee
56209621	1	Replacement Blades for 56209233
56409563	1	Wand Two Piece
56100372	1	14" Hard Floor Tool
56100373	1	14" Soft Floor Tool
56202088	1	Vandar Two Bend Steel Wand
56205114	1	Vandar 14" Squeegee Tool
56205116	1	Vandar 14" Replacement Squeegee Cartridge (includes two blades)
56205120	1	Vandar 20" Squeegee Tool
56205122	1	Vandar 20" Replacement Squeegee Cartridge (includes two blades)
56390000	1	Wet Pick Up Kit
56205114	1	14" Vandar Squeegee Tool
56202088	1	Steel Wand
56204213	1	1.50" x 10' Hose Assembly
56209490	1	70PPI Filter Kit
56044612	1	Literature Pack



Nilfisk-Advance Equipamentos de Limpeza Ltda.
Av. Dep. Emílio Carlos, 2.499 - Bairro do Limão - 02721-200
São Paulo - SP - Brasil
www.nilfisk-advance.ind.br
www.plataforma.ind.br
Tel.: (11) 3959-0300
Fax: (11) 3959-0306
©2011 Nilfisk-Advance, Inc.



14600 21st Avenue North
Plymouth, MN 55447-3408
www.advance-us.com
Phone: 800-989-2235
Fax: 800-989-6566
©2011 Nilfisk-Advance, Inc.

A Nilfisk-Advance Brand